

DATASHEET

Steel Base for Power Magic

Technical Data

Model	Steel Base for Storage Cabinet
Code	ZPM-BASE-SC1
Material	Black painted steel
Dimensions (L*W*H)	1455x1300x300mm
Weight	100 Kg

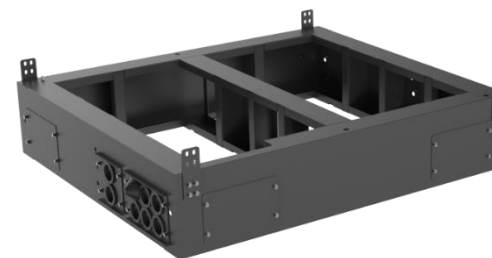

Model	Steel Base for Battery Cabinet
Code	ZPM-BASE-BC1
Material	Black painted steel
Dimensions (L*W*H)	1005x1300x300mm
Weight	70 Kg

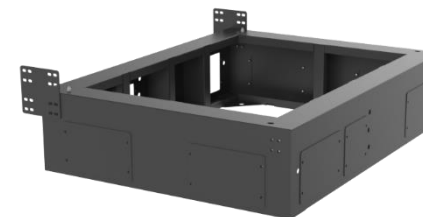

Model	Steel Base for Junction Cabinet
Code	ZPM-BASE-PJC
Material	Black painted steel
Dimensions (L*W*H)	705x646x300mm
Weight	50 Kg





Junction Cabinet

Energy Storage Cabinet

Battery Cabinets

Steel Base

Steel base for single Storage Cabinet

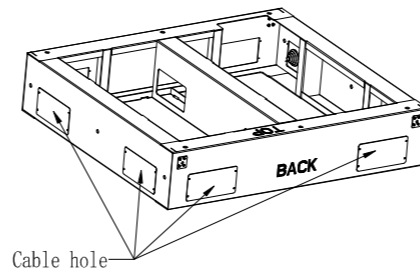
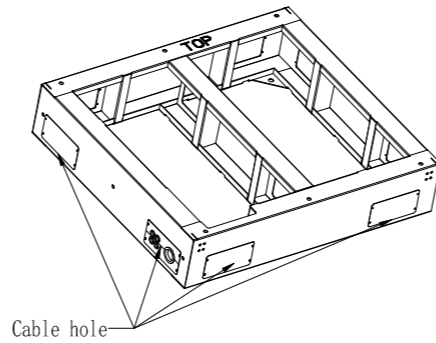
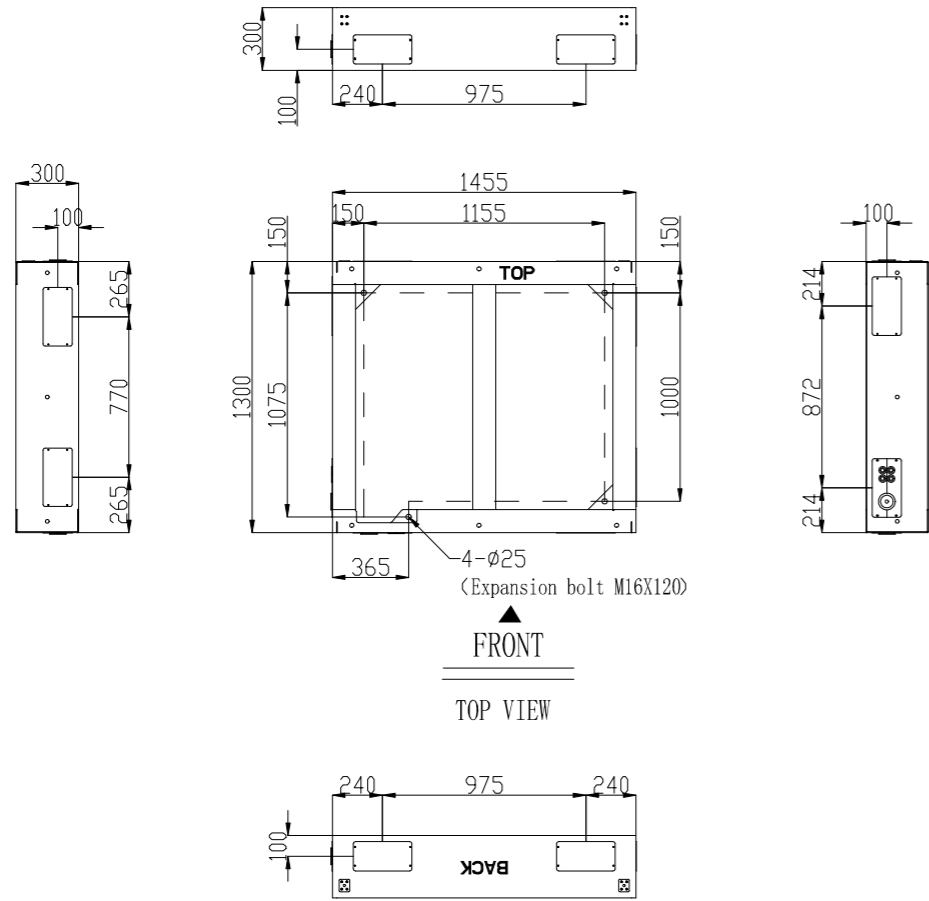
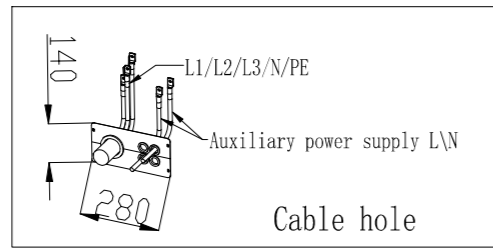

Note: See the installation manual shipped with the steel base for installation instructions

Product adaptation diagram

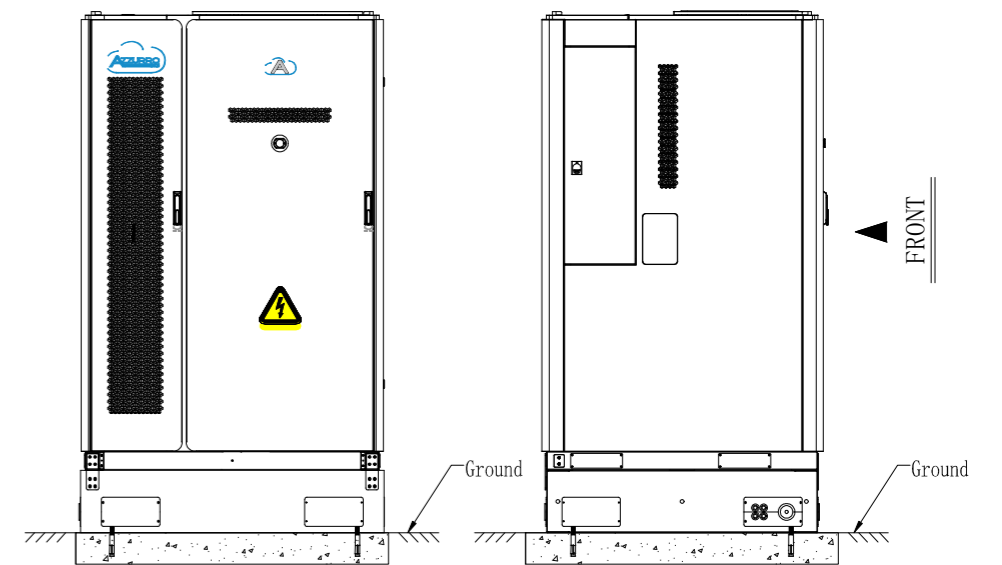
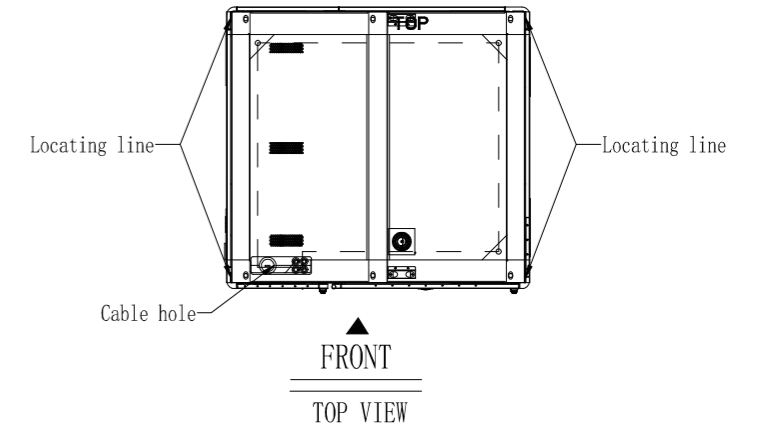

Technical requirements:

1. It should be explained that the entire energy storage system weighs about 3000KG. And the ground bearing capacity needs to be greater than 6000KG!
2. The steel base is installed on a concrete plane. It is recommended to reserve four bottom holes for M16 expansion bolts on the mounting surface. The depth is 100mm(M16*120 expansion bolt). And the exposed length of the expansion bolt should ensure that 6 to 8 silk teeth are exposed after the nut is tightened.
3. The installation surface of the equipment should be levelled to ensure that the installation surface is horizontal. And the surface tolerance is ± 3 mm.
4. After installing the steel base, the highest surface must be higher than the local historical highest water level. If the self-infiltration inside the foundation can not meet the drainage requirements, it is necessary to make a separate drainage channel.
5. The sealing plate area can enter the line, the direction of the entrance depends on the scene. It is recommended to reserve cable pipelines (for the specific dimensions, select the cable diameter specifications based on the demand side, and reserve sufficient allowance for easy threading).
6. All matters not mentioned in the figure shall be subject to the current norms of the country where they are located. Unit: mm.

				Zuchetti Centro sistemi S. p. A.	
Design:	Date:	Mappable Unit	A3	Ratio:	1:1
Check:	Date:			Weight:	
Ratify:	Date:	Unit:	mm	Part Number	
		versions:		First page	One page in total

Steel Base for Storage Cabinet with one Battery Cabinet

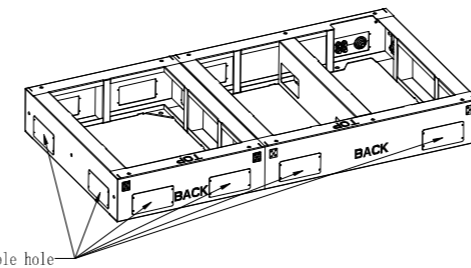
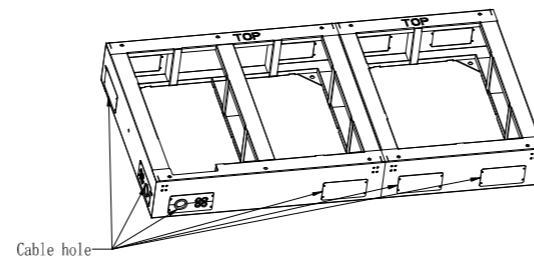
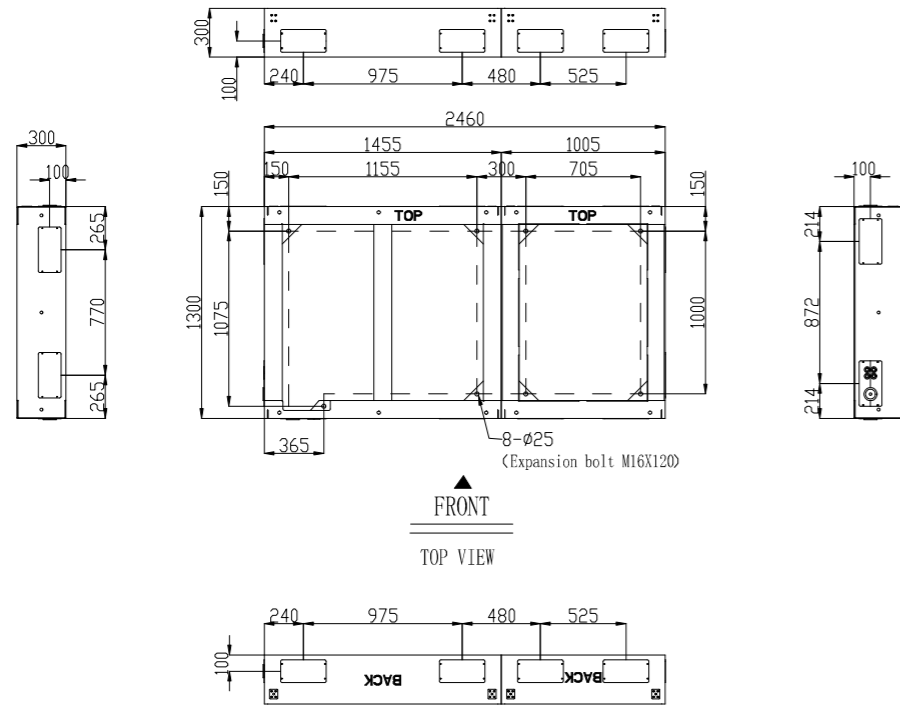
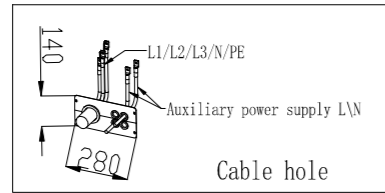

Note: See the installation manual shipped with the steel base for installation instructions

Product adaptation diagram

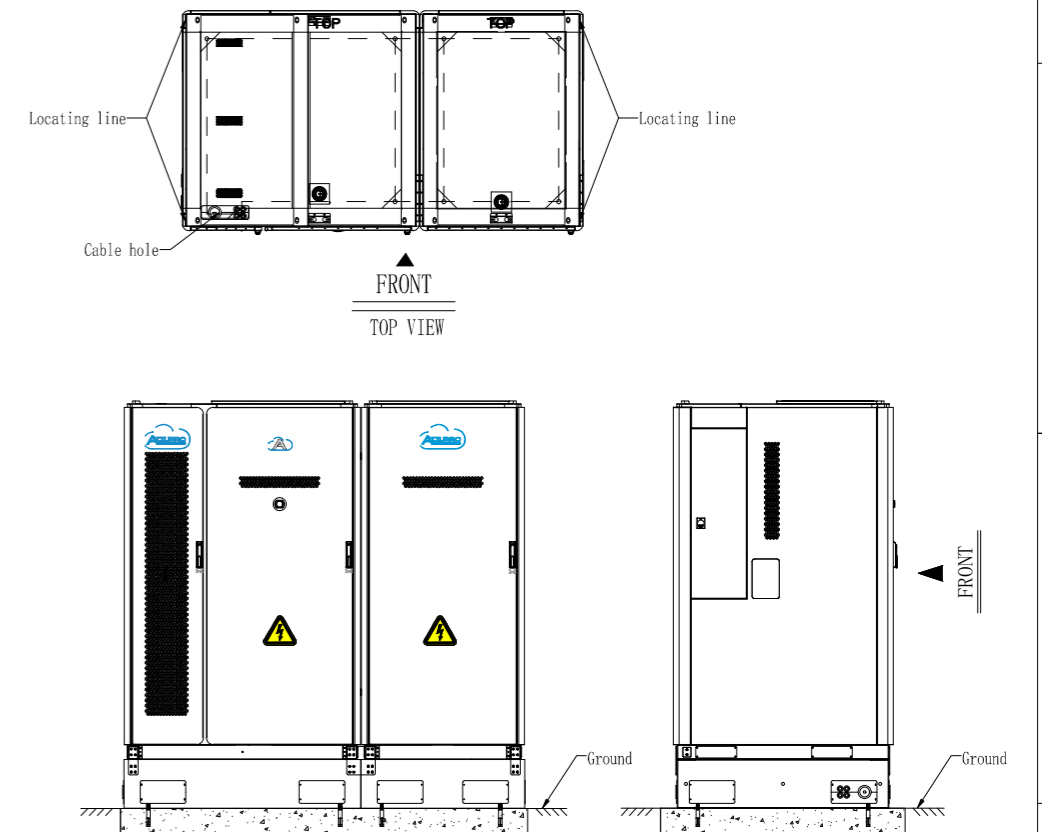

Technical requirements:

1. It should be explained that the entire energy storage system weighs about 5500KG. And the ground bearing capacity needs to be greater than 1100KG!
2. The steel base is installed on a concrete plane. It is recommended to reserve eight bottom holes for M16 expansion bolts on the mounting surface. The depth is 100mm(M16*120 expansion bolt). And the exposed length of the expansion bolt should ensure that 6 to 8 silk teeth are exposed after the nut is tightened.
3. The installation surface of the equipment should be levelled to ensure that the installation surface is horizontal. And the surface tolerance is $\pm 3\text{mm}$.
4. After installing the steel base, the highest surface must be higher than the local historical highest water level. If the self-infiltration inside the foundation can not meet the drainage requirements, it is necessary to make a separate drainage channel.
5. The sealing plate area can enter the line, the direction of the entrance depends on the scene. It is recommended to reserve cable pipelines (for the specific dimensions, select the cable diameter specifications based on the demand side, and reserve sufficient allowance for easy threading).
6. All matters not mentioned in the figure shall be subject to the current norms of the country where they are located. Unit: mm.

				Zuchetti Centro sistemi S. p. A.	
Design:		Mappable Unit	A3	Ratio:	1:1
Check:		Date:		Weight:	
Ratify:		Date:		Unit:	mm
		versions:		Part Number	
				First page	One page in total

Steel Base for Storage Cabinet with two Battery Cabinets

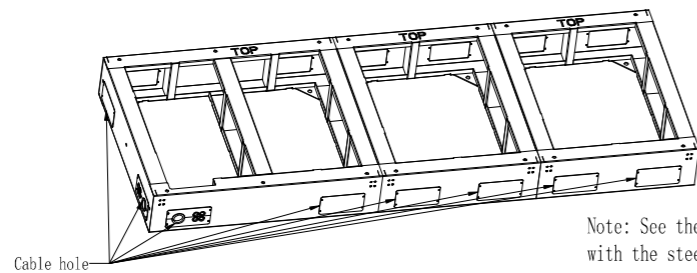
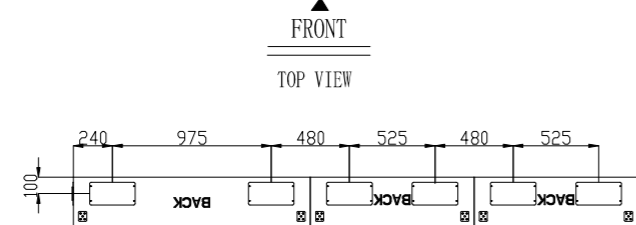
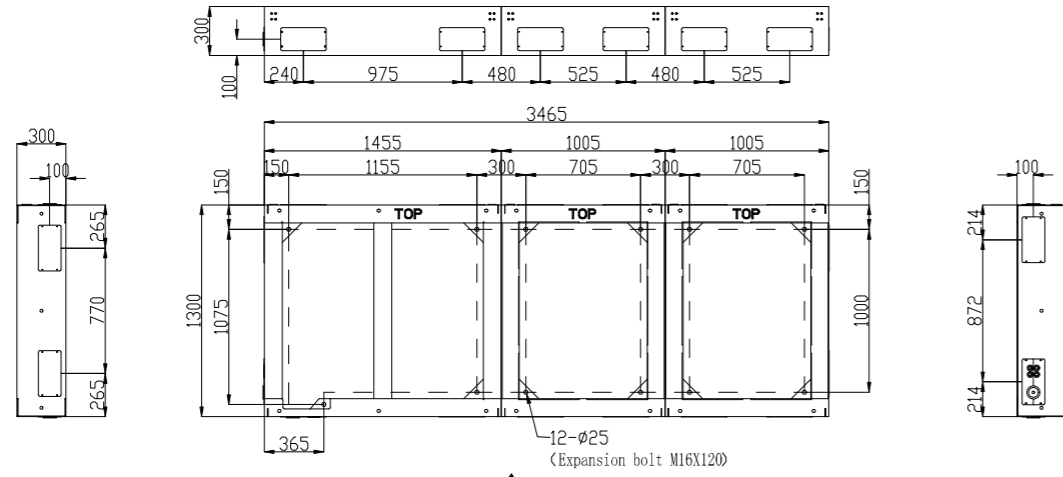
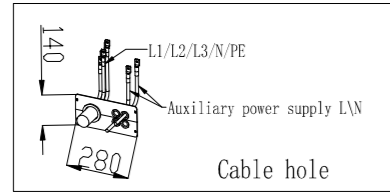

Note: See the installation manual shipped with the steel base for installation instructions

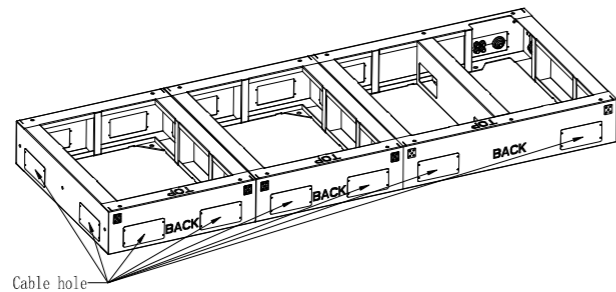

Technical requirements:

1. It should be explained that the entire energy storage system weighs about 8000KG. And the ground bearing capacity needs to be greater than 1600KG!
2. The steel base is installed on a concrete plane. It is recommended to reserve twelve bottom holes for M16 expansion bolts on the mounting surface. The depth is 100mm(M16*120 expansion bolt). And the exposed length of the expansion bolt should ensure that 6 to 8 silk teeth are exposed after the nut is tightened.
3. The installation surface of the equipment should be levelled to ensure that the installation surface is horizontal. And the surface tolerance is $\pm 3\text{mm}$.
4. After installing the steel base, the highest surface must be higher than the local historical highest water level. If the self-infiltration inside the foundation can not meet the drainage requirements, it is necessary to make a separate drainage channel.
5. The sealing plate area can enter the line, the direction of the entrance depends on the scene. It is recommended to reserve cable pipelines (for the specific dimensions, select the cable diameter specifications based on the demand side, and reserve sufficient allowance for easy threading).
6. All matters not mentioned in the figure shall be subject to the current norms of the country where they are located. Unit: mm.

Product adaptation diagram

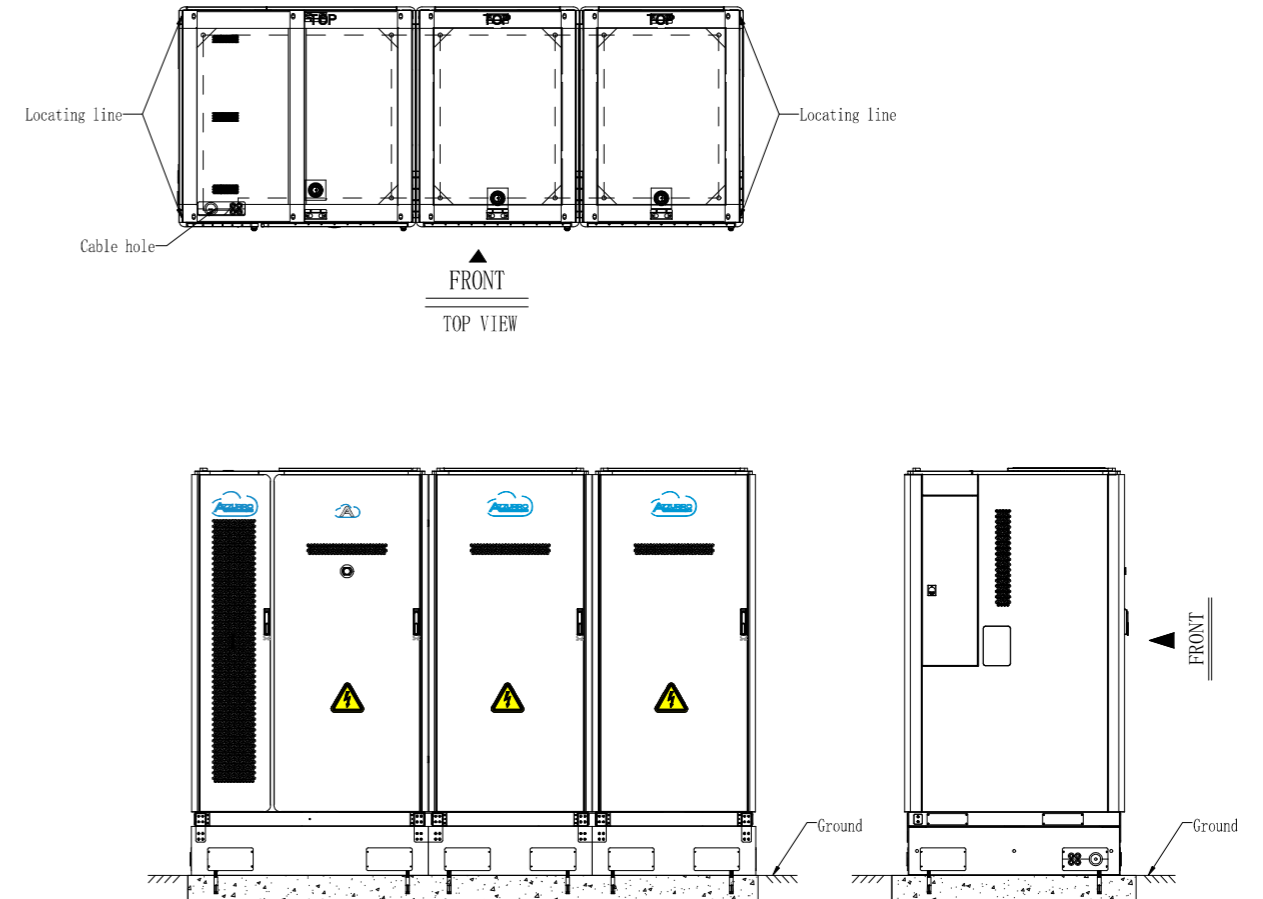

				Zucchetti Centro sistemi S. p. A.		
Design:	Mappable Unit	A3	Ratio:	1:1	Name: Foundation of one 400V Energy Storage Cabinet and two 400V Battery Cabinet	
Check:	Date:		Weight:			
Ratify:	Date:		Unit:	mm	Part Number	
			versions:		First page	One page in total

Steel Base for Storage Cabinet with three Battery Cabinets

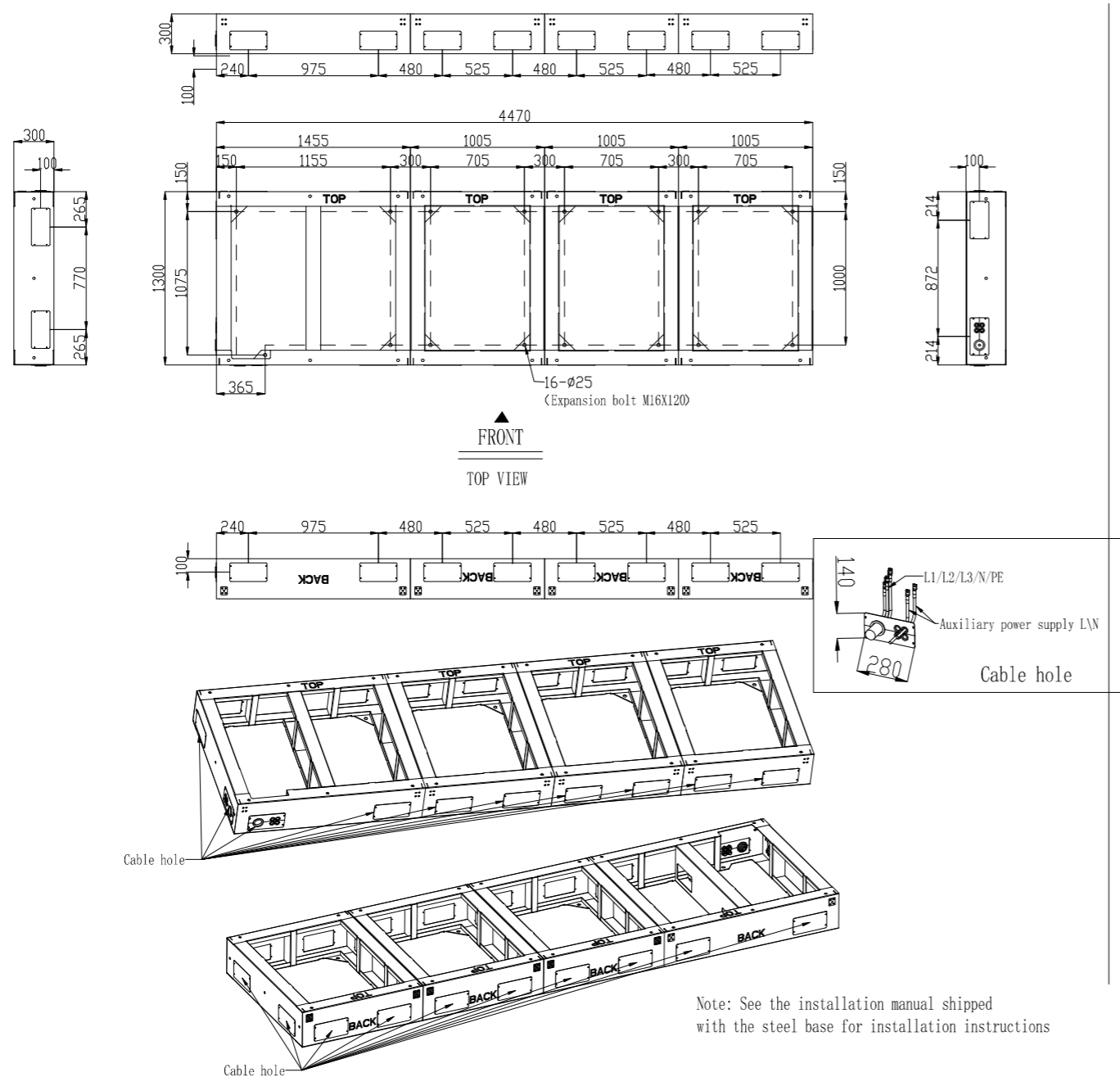

Note: See the installation manual shipped with the steel base for installation instructions

Technical requirements:

1. It should be explained that the entire energy storage system weighs about 10500KG. And the ground bearing capacity needs to be greater than 21000KG!
2. The steel base is installed on a concrete plane. It is recommended to reserve sixteen bottom holes for M16 expansion bolts on the mounting surface. The depth is 100mm(M16*120 expansion bolt). And the exposed length of the expansion bolt should ensure that 6 to 8 silk teeth are exposed after the nut is tightened.
3. The installation surface of the equipment should be levelled to ensure that the installation surface is horizontal. And the surface tolerance is ± 3 mm.
4. After installing the steel base, the highest surface must be higher than the local historical highest water level. If the self-infiltration inside the foundation can not meet the drainage requirements, it is necessary to make a separate drainage channel.
5. The sealing plate area can enter the line, the direction of the entrance depends on the scene. It is recommended to reserve cable pipelines (for the specific dimensions, select the cable diameter specifications based on the demand side, and reserve sufficient allowance for easy threading).
6. All matters not mentioned in the figure shall be subject to the current norms of the country where they are located. Unit: mm.

Product adaptation diagram

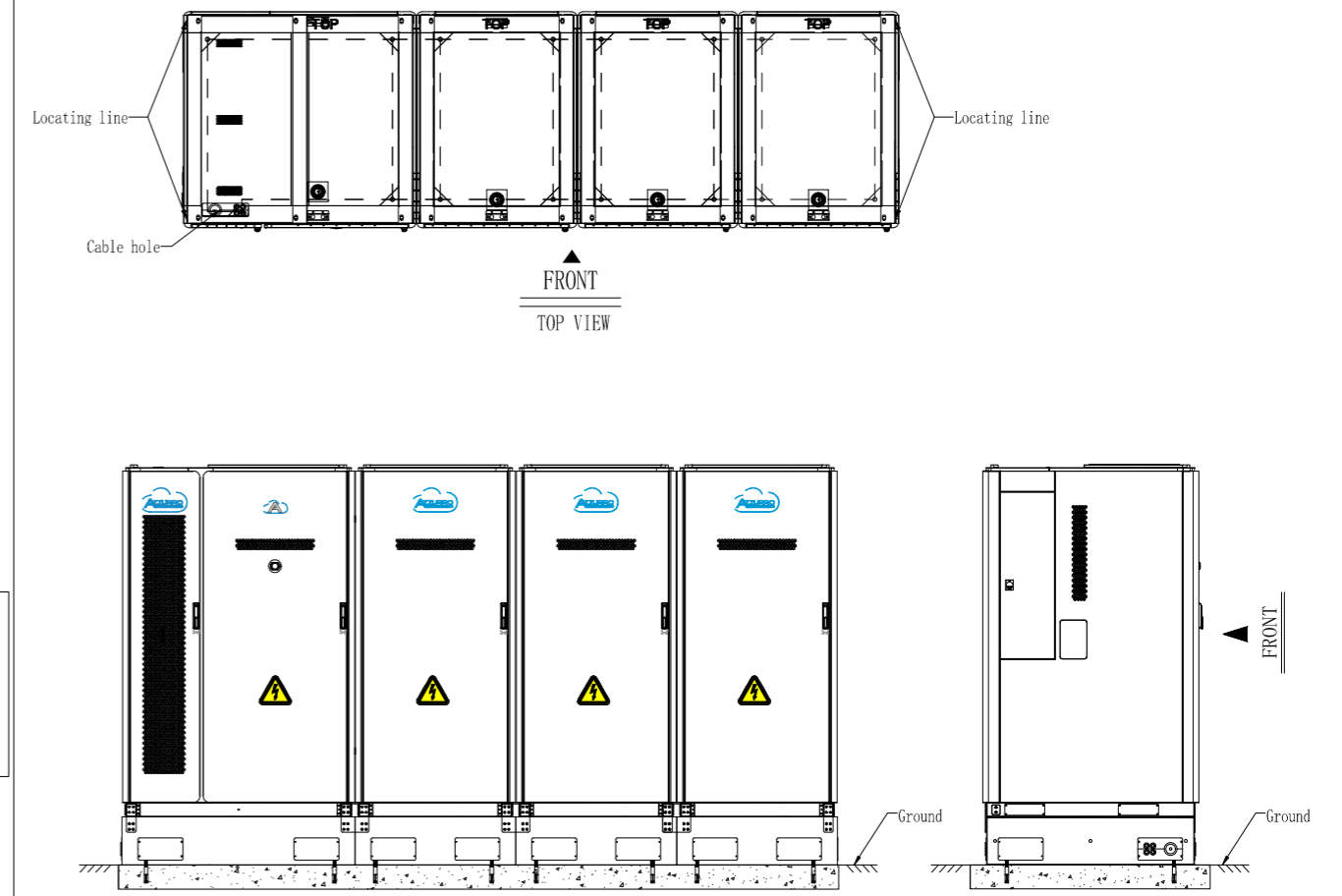

				Zuchetti Centro sistemi S.p.A.	
Design:	Date:	Mappable Unit:	A3	Ratio:	1:1
Check:	Date:	Weight:		Name: Foundation of one 400V Energy Storage Cabinet and three 400V Battery Cabinet	
Ratify:	Date:	Unit:	mm	Part Number:	
		versions:		First page	One page in total