

QUICK INSTALLATION GUIDE

ZCB8000-64/80/96KWH

Rev.0.0 del 13.03.2026

Instructions

- All operations on this equipment must be carried out by trained and qualified electrical technicians or certified commissioning personnel. Operators must be fully familiar with the system structure, operating principles, and the relevant standards of the country/region where the project is located.
- Please read the user manual carefully before installing the equipment to understand the product information and safety precautions. Any damage caused by storage, transportation, installation, or operation that is not performed in accordance with this document and the user manual is not covered under the product warranty.
- Insulated tools must be used during installation. For personal safety, please wear personal protective equipment (PPE).
- During installation or operation, if personnel leave for a short period of time, the cabinet door must be closed.
- If the equipment is scratched or the paint is peeled due to impact during transportation or installation, please repair it using outdoor paint Y3-1172W (white) or RAL9011 (black).
- For the binding locations of the supplied installation parts, screws, and other accessories, please refer to the "Packing List".

01 INSTALLATION REQUIREMENT

To ensure sufficient airflow at the air inlet and facilitate maintenance, it is needed to reserve adequate space around the cabinet installation area. The minimum required space is shown in the figures below.

► 1 PCS Energy Storage Cabinet Installation Space

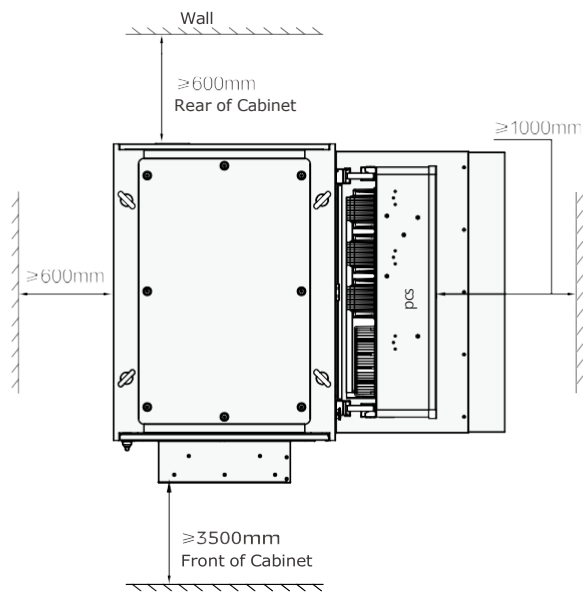

01 | ZCB8000-64/80/96KWH

► 4 PCS Energy Storage Cabinets Installed Face-to-Face

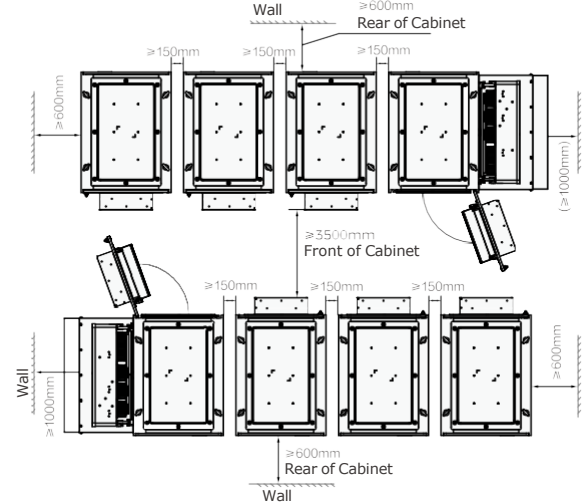

► 4 PCS Energy Storage Cabinets Installed Back-to-Back

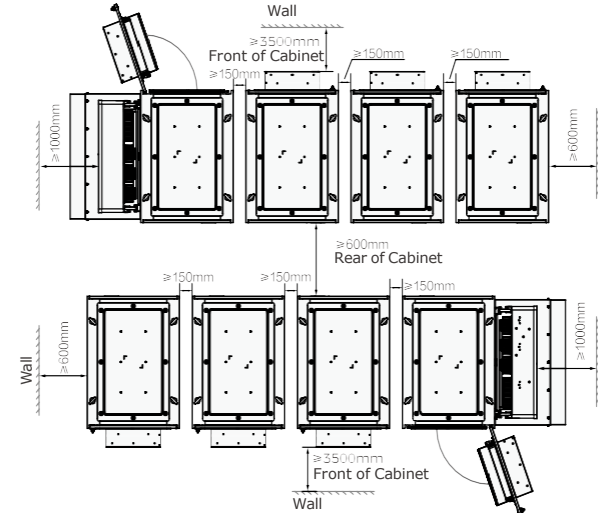

ZCB8000-64/80/96KWH | 02

02 PRODUCT OVERVIEW

Instructions

The foundation requirements shall follow the description provided in the construction site design drawings. For detailed drawings, please contact the distributor or after-sales.

► Energy Storage Cabinet Diagram

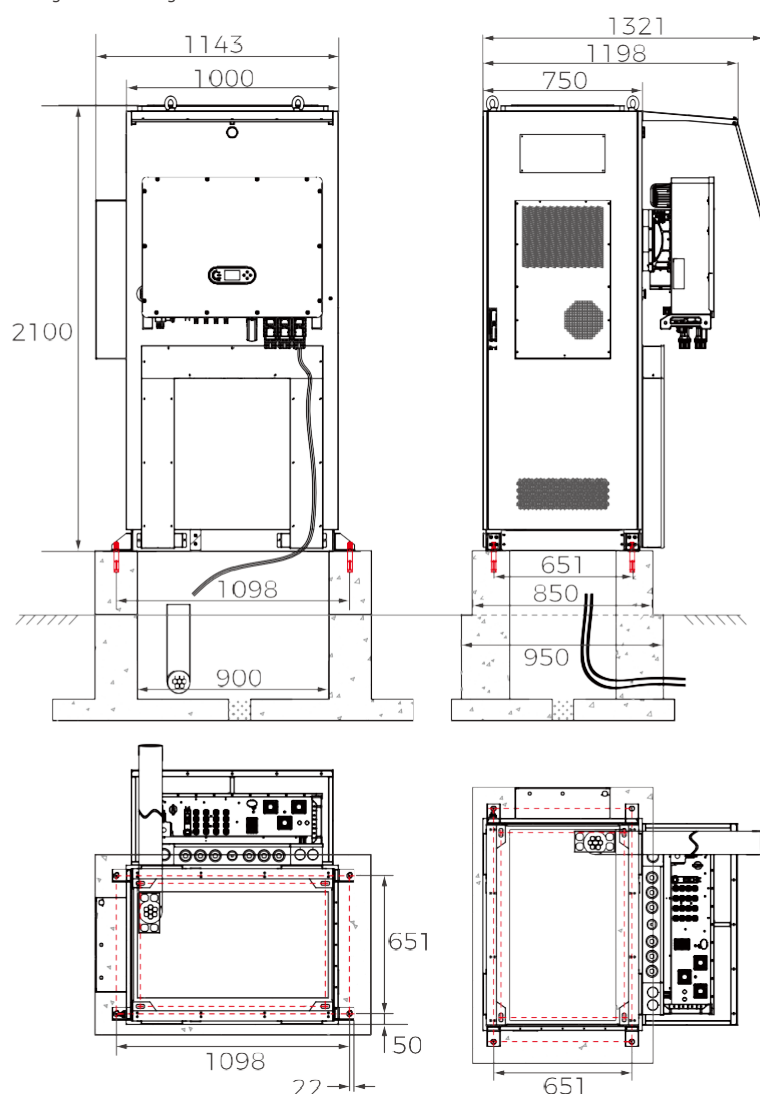

► Energy Storage Cabinets Parallel Connection Diagram

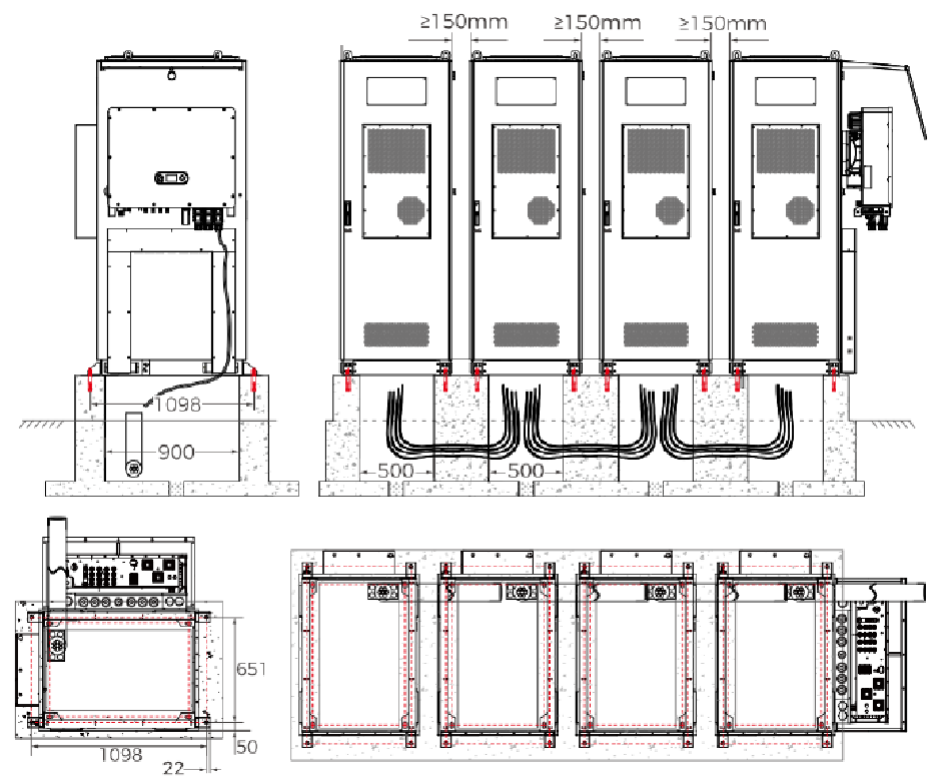

03 CHECK THE DELIVERY LIST

Standard Configuration

Energy Storage Cabinet + Accessory Kit for the Cabinet + Other Customized Requirements (as picture shown below)

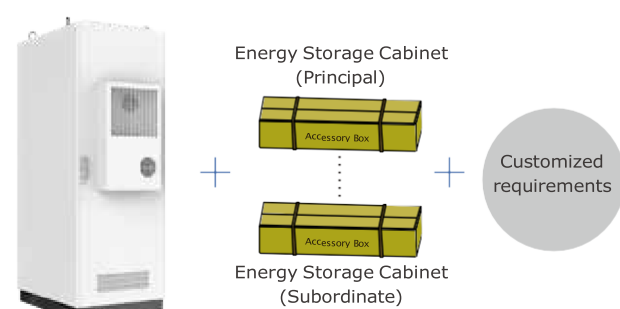









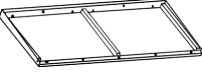
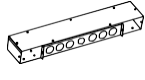
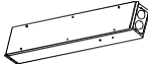
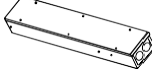









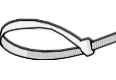













03 | ZCB8000-64/80/96KWH





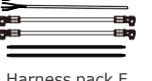

ZCB8000-64/80/96KWH | 04

Instructions

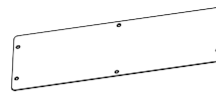
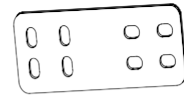
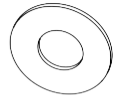
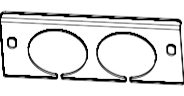
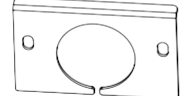
Please check the delivered items and their quantities against the "Shipping List" and the "Packing List". If any items are missing, please contact the distributor or after-sales.











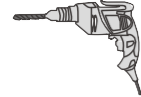
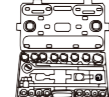
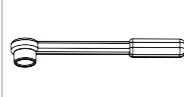
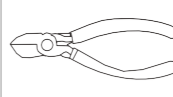
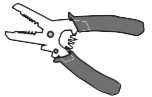
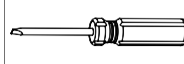

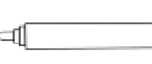

Energy storage cabinet (A) ZZT-POWER-MINI-KIT				
	1PCS			
				1PCS
	Harness pack A			1PCS
				
Waterproof connector	M10*30 4 PCS	M5*12 16 PCS	M4*12 25 PCS	M6*30 12PCS
				/
50 (KKT*50) 6PCS	40 (KKT*40) 1 PCS	1 PCS	20PCS	
Energy storage cabinet (B) ZZT-POWER-MINI-KIT-20M				
	1PCS			
				
M20 4PCS	1PCS	20PCS	1PCS	Harness pack B
Energy storage cabinet (C) ZZT-POWER-MINI-KIT-100M				
	1PCS			
				
M20 4PCS	1PCS	20PCS	1PCS	Harness pack C
Energy storage cabinet (E) ZZT-POWER-MINI-FIX				
	1PCS			
				/
4PCS	M8*25 18 PCS	20PCS	M16*150 5PCS	
Energy storage cabinet (F) ZZT-POWER-MINI-KIT-PAR				
	1PCS			
				
M20 4PCS	1PCS	20PCS	Harness pack F	

05 | ZCB8000-64/80/96KWH

Steel base ZZT-BASE-POWER-MINI			
			
1PCS	2PCS	4PCS	4PCS
			
4PCS	4PCS	M16*150 5PCS	70 (KKT*70) 12PCS
			/
M16*40 6PCS	M16*13 6PCS	M8*25 61PCS	

04 INSTALLATION

4.1 TOOLS

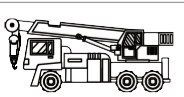
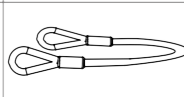
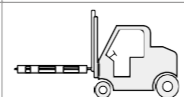
				
Hammer Drill (Drill Bits: Φ 14 mm, Φ 16 mm)	Socket Wrench	Torque Wrench	Diagonal Pliers	Wire Stripper
				
Flat-head Screwdriver (head: 0.6 mm*3.5 mm)	Rubber Hammer	Utility Knife	Marker	Steel Tape Measure
				
Digital or Bubble Level	Hydraulic Crimper	Cable Cutter	RJ45 Crimping Tool	Multimeter (DC Voltage Range ≥ 1500V DC.)
				
Heat Shrink Tubing	Heat Gun	Cable Ties	Insulated Ladder	Vacuum Cleaner
			/	
Crane	Lifting Rope	Forklift		

ZCB8000-64/80/96KWH | 06

4.2 LIFTING AND FORKLIFT TRANSPORT

Lifting

Use 4 PCS "M20*30 Lifting Rings", which can be obtained from the supplied accessory kit.

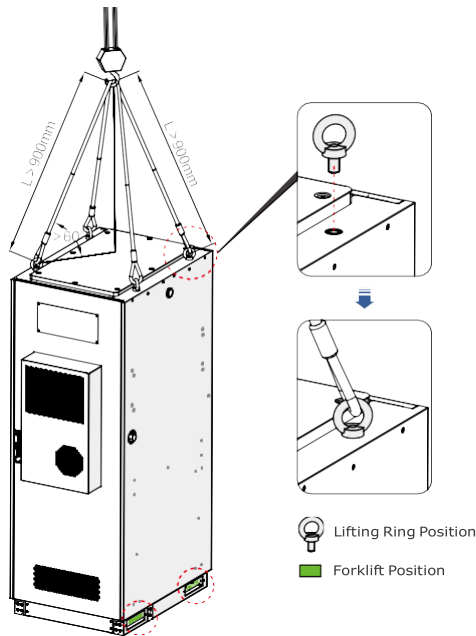

Instructions

- Before lifting, ensure that the concrete foundation meets the installation requirements, the foundation surface has proper positioning marks, and the energy storage system is correctly oriented to match the marks.
- The crane lifting capacity must be greater than 6T, with a working radius of no less than 5 m.

Forklift Transport

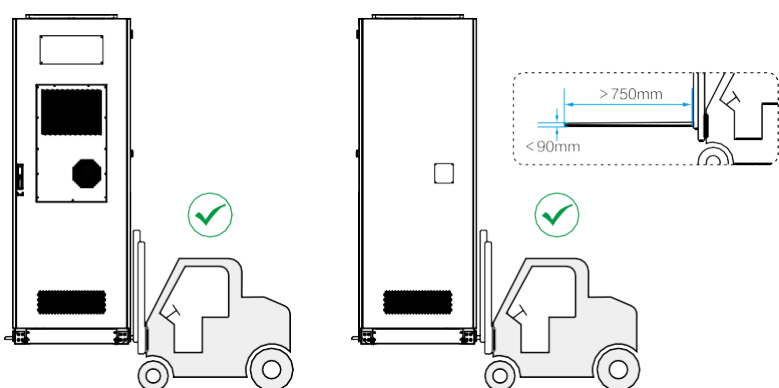

07 | ZCB8000-64/80/96KWH

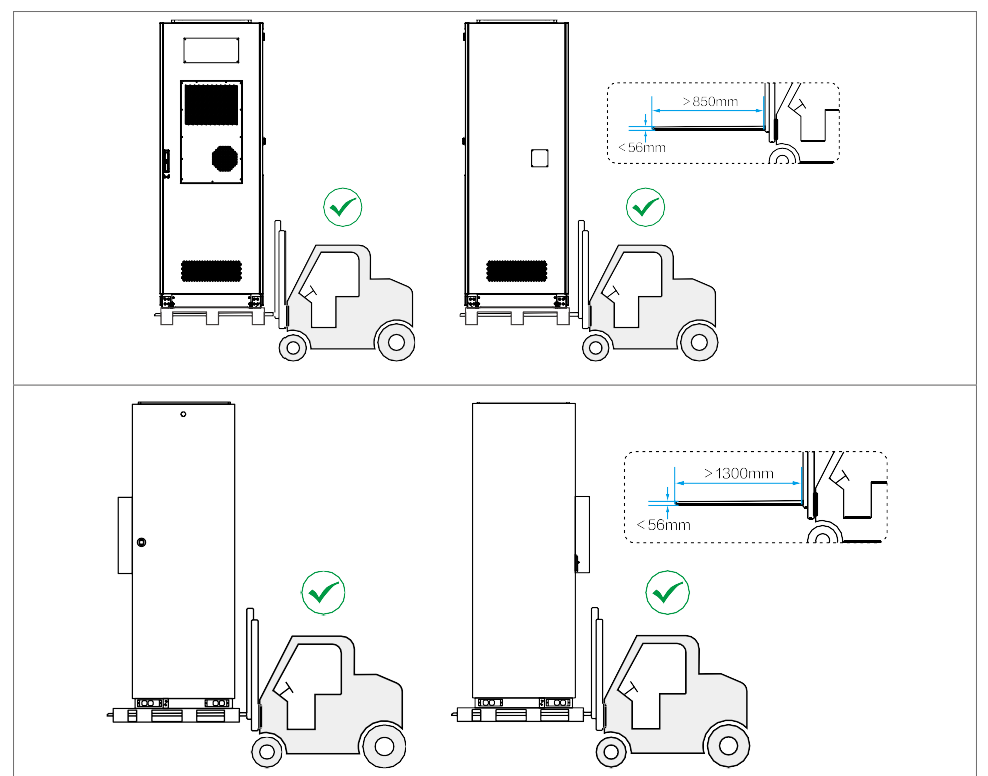

Instructions

- Forklift load capacity must be greater than 4T. If the field working conditions do not meet the requirements, please contact a professional for assessment.

4.3 INSTALLING THE ENERGY STORAGE SYSTEM

Standard Installation (Without Steel Base)

- Take out 4 PCS "M16*150 Expansion Bolts" from the supplied accessory kit.
- Embed the expansion bolts into the concrete foundation according to the required installation dimensions.
- Secure the cabinet to the concrete floor using the expansion bolts.
- Complete the installation and perform an inspection.

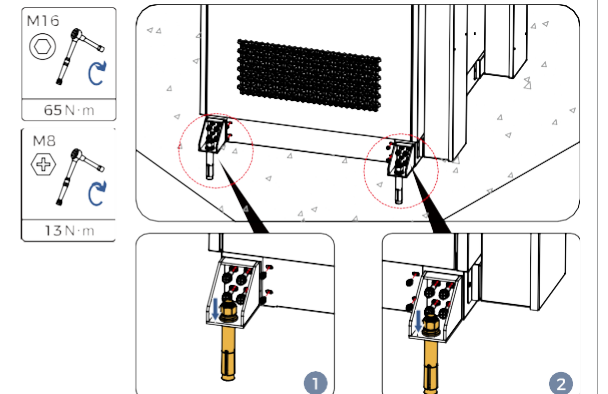

ZCB8000-64/80/96KWH | 08

► Steel Base Installation (Optional: If this accessory is not purchased, please proceed with the standard installation.)

1. Lift or move the steel base to the designated position, ensuring that the "Black" side on the steel base faces the opposite direction of the intended door-opening orientation of the equipment.
2. Secure the steel base to the concrete floor using expansion bolts.
3. Fasten the energy storage cabinet firmly onto the steel base using bolts.
4. Install the cover plates and the parallel connection metal components.
5. Complete the installation and carry out an inspection.

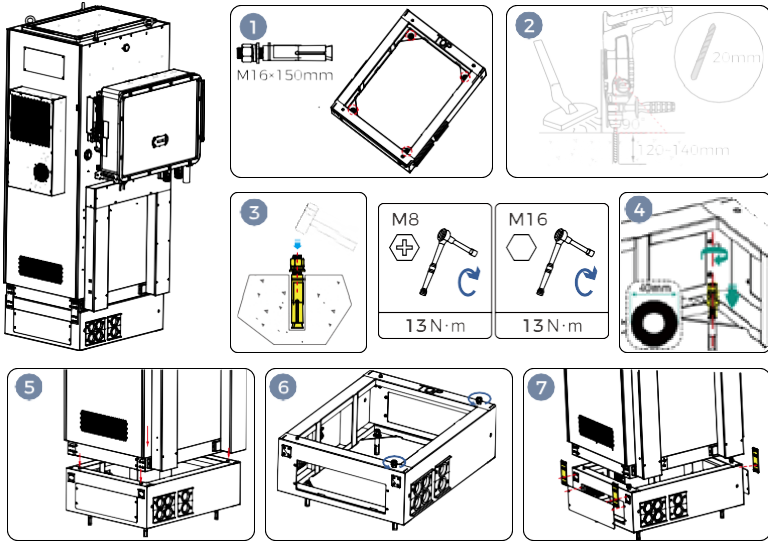

05 INSTALL THE ENERGY STORAGE SYSTEM SUNSHADE

Use 11 PCS "M6*30 screws" and 2 PCS "M5*12 screws" from the accessory kit. The sunshade is also included in it.

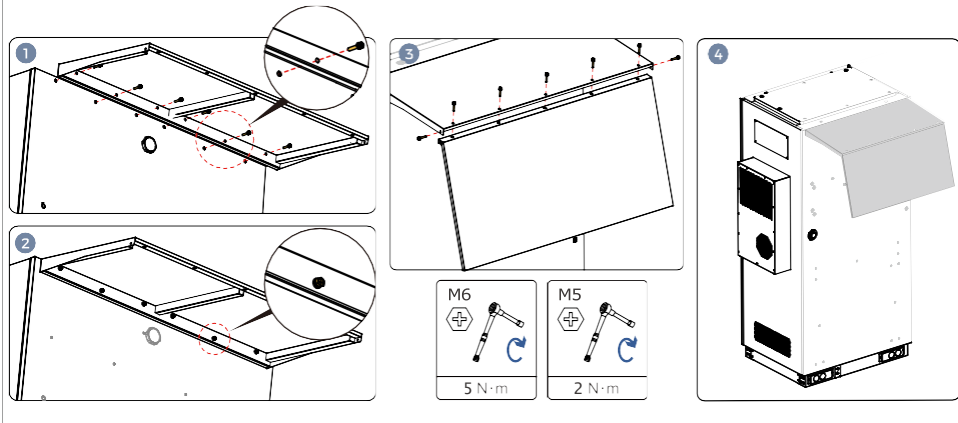

09 | ZCB8000-64/80/96KWH

06 INSTALL THE PV INVERTER BRACKET

Use 4 PCS "M10*30 screws" from the accessory kit. The PV inverter bracket is included in the PV inverter package.

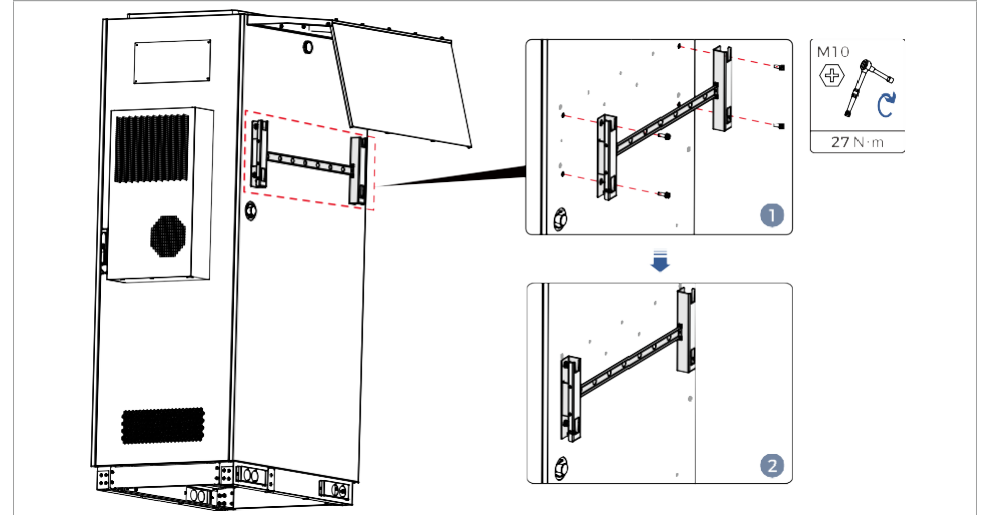

07 INSTALL THE ENERGY STORAGE SYSTEM CABLE TRAYS

Use 23 PCS "M4*12 screws", 13 PCS "M5*12 screws", 10 Grommet 50 (KKT50), and 1 Grommet 40 (KKT40) from the accessory kit. The cable trays are also included in the kit.

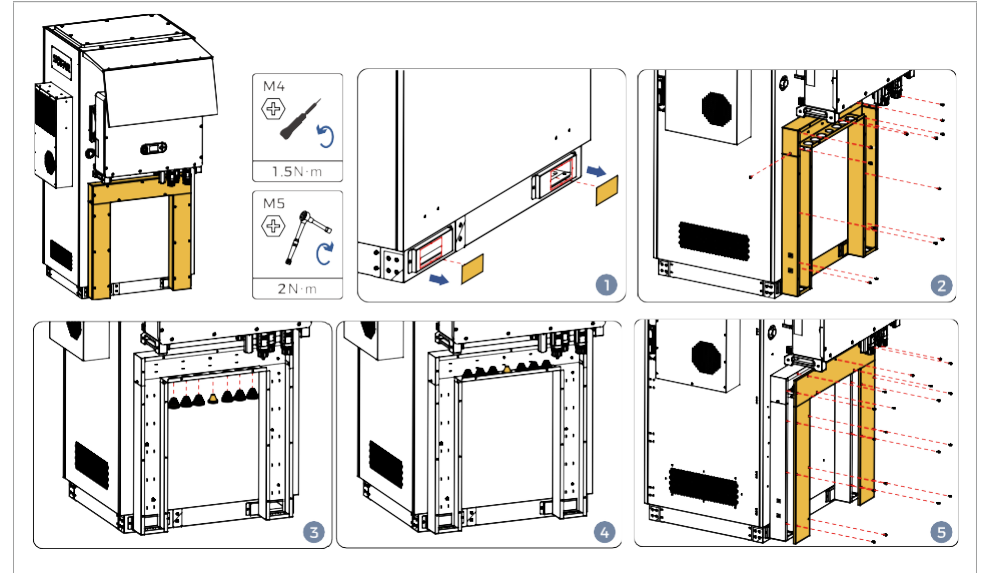

ZCB8000-64/80/96KWH | 10

08 INSTALL THE ENERGY STORAGE SYSTEM GROUNDING PROTECTION WIRE

Use 4 PCS "M10*30" screws from the accessory kit. Ensure the grounding resistance is $\leq 4 \Omega$.

► Grounding Cable
Use a 25mm² to 50mm² grounding cable to ensure a reliable connection between the energy storage cabinet and the grounding point of the site grounding grid.

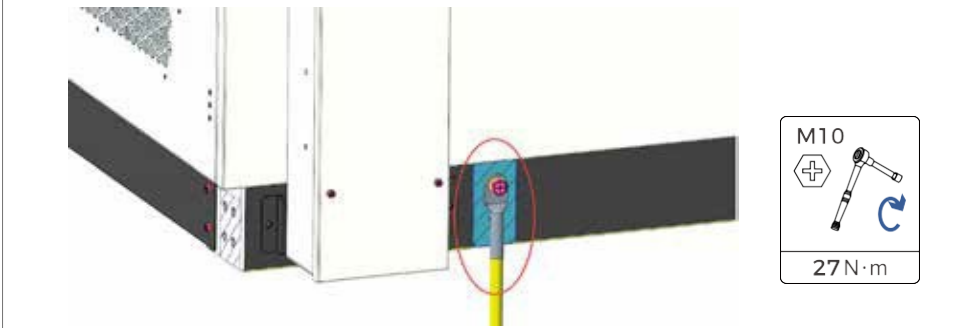

09 AIR CONDITIONING DRAIN PIPE INSTALLATION

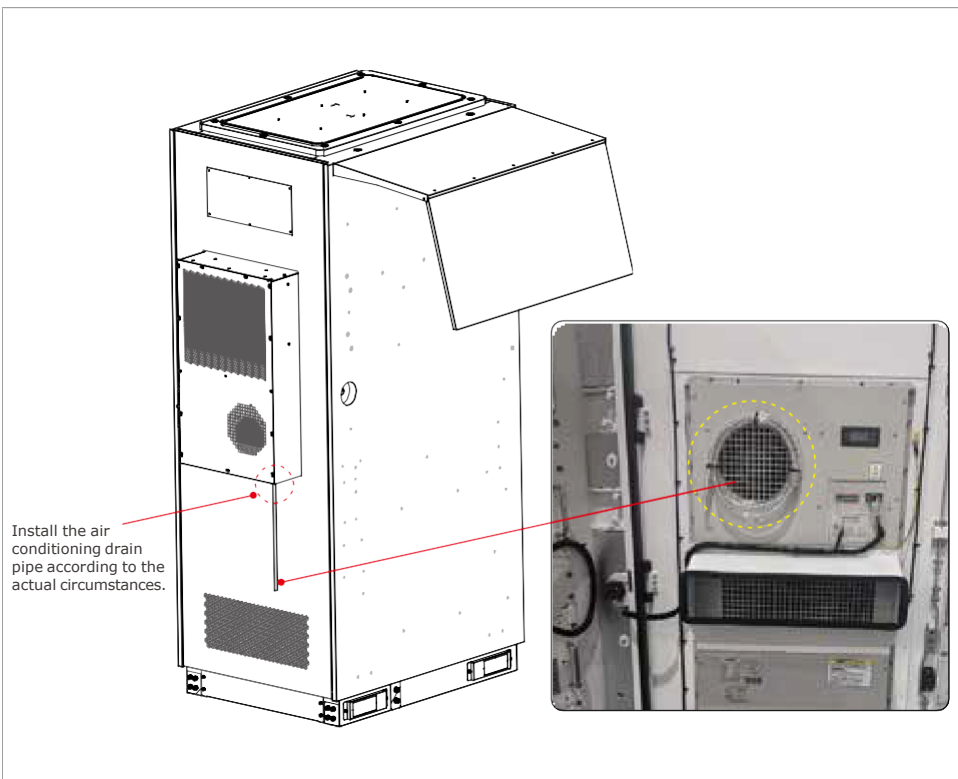

11 | ZCB8000-64/80/96KWH

10 INSTALL THE CABLES

10.1 PREPARE THE REQUIRED CABLES AND OBTAIN THEM FROM THE SUPPLIED ACCESSORY KIT

1. Connect power cables between BCU and inverter

Connect the BCU power cables, ensuring correct cable polarity. Route the cables along the cabinet and cable trays, and fully insert the cable terminals until a "click" sound is heard.

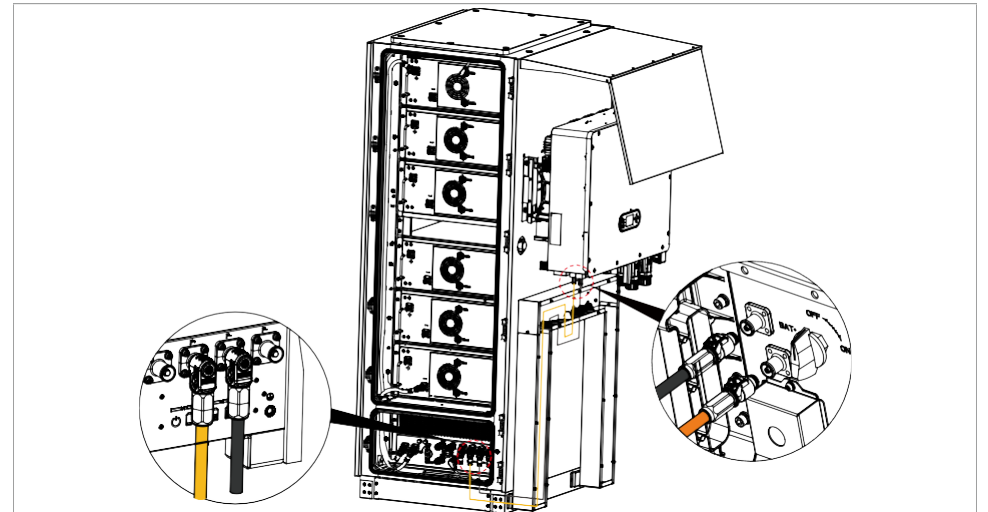

2. Connect communication cables between BCU and inverter.

2.1 BCU communication terminal waterproof cover

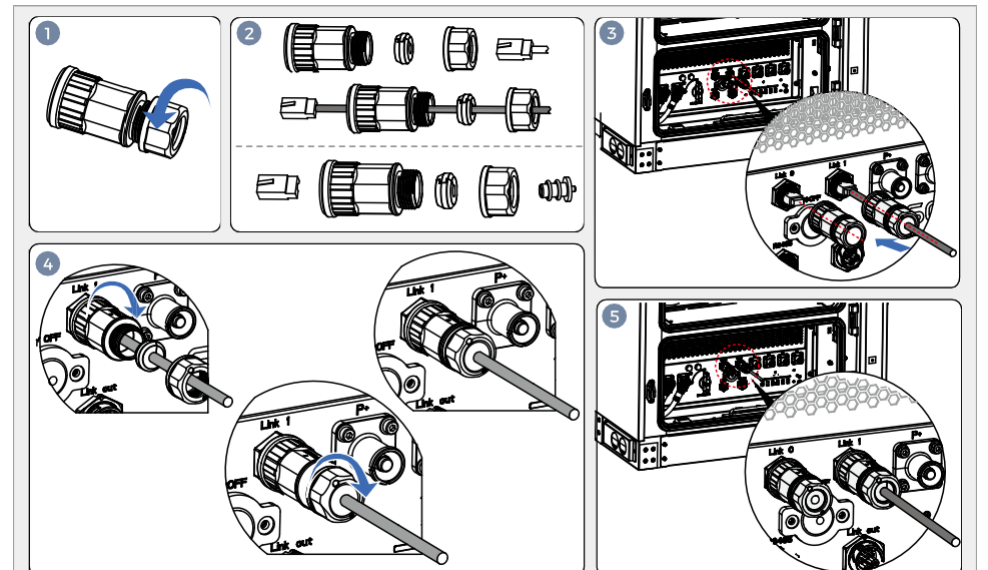

ZCB8000-64/80/96KWH | 12

2.2 Route the communication cables along the cabinet and cable trays, and connect them to the inverter COM connector.

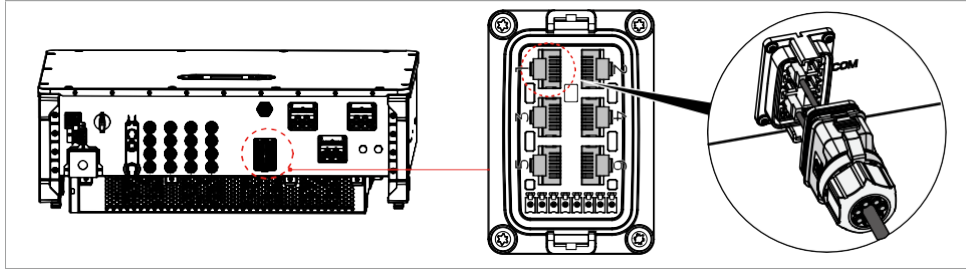

3. Connect power cables between cabinet and Inverter.

Route the dedicated cabinet power cables along the cabinet and cable trays, and connect them to the inverter load port.

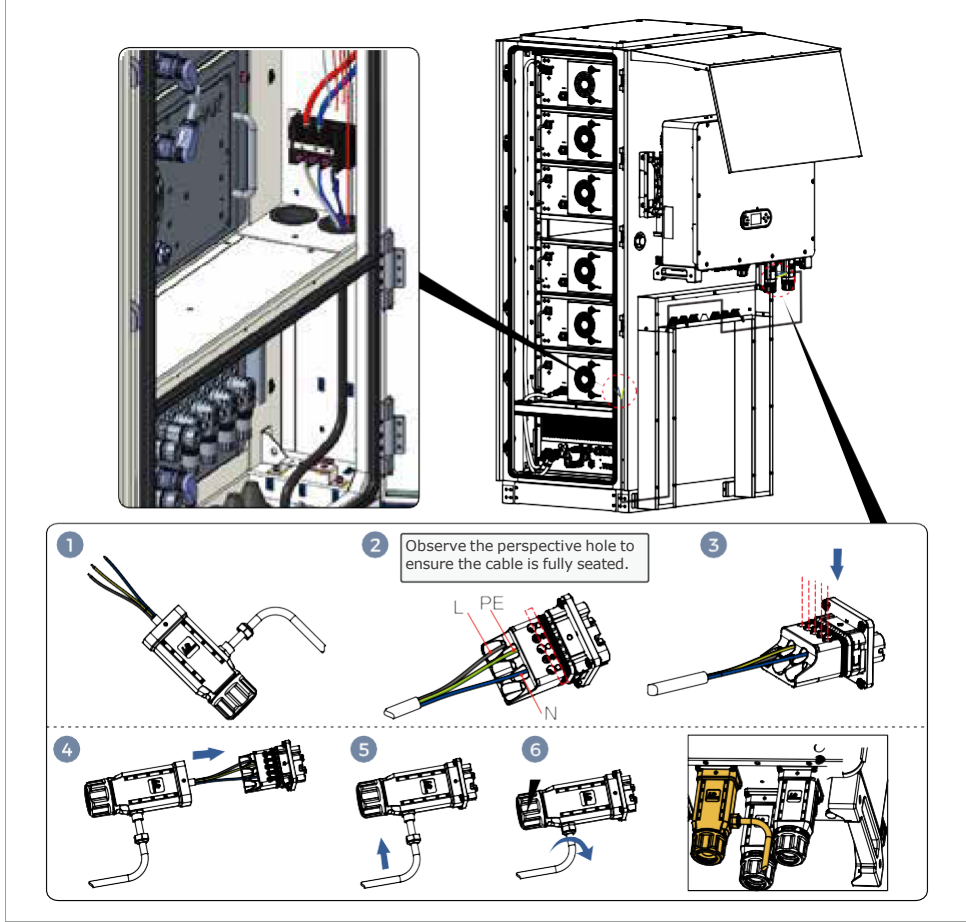

4. Emergency shutdown wiring.

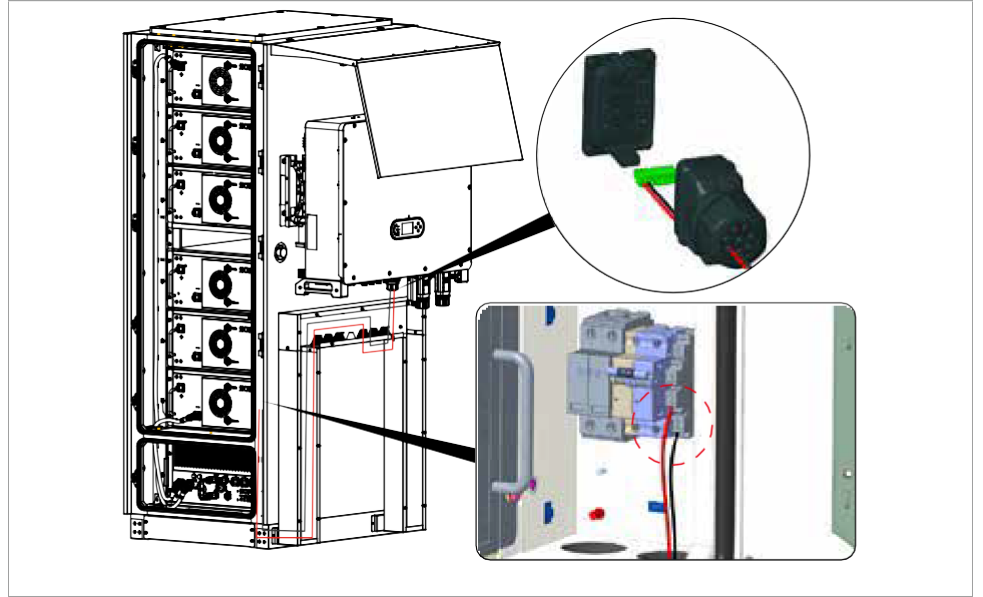

5. Parallel connection with inverter.

① Battery and communication cable connection.

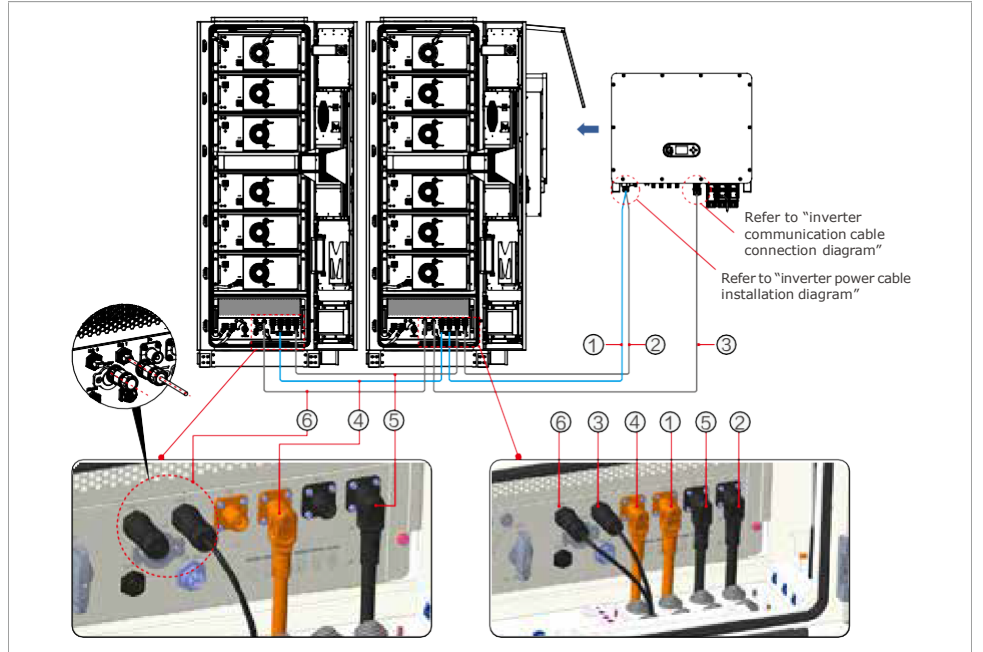

② Parallel power supply cable connection.

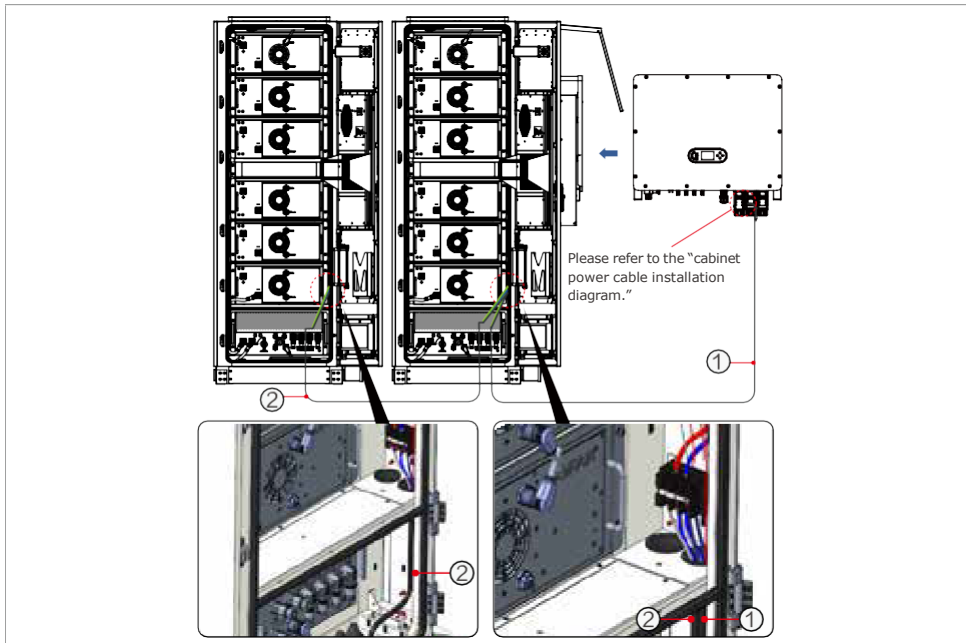

③ Parallel EPO button connection.

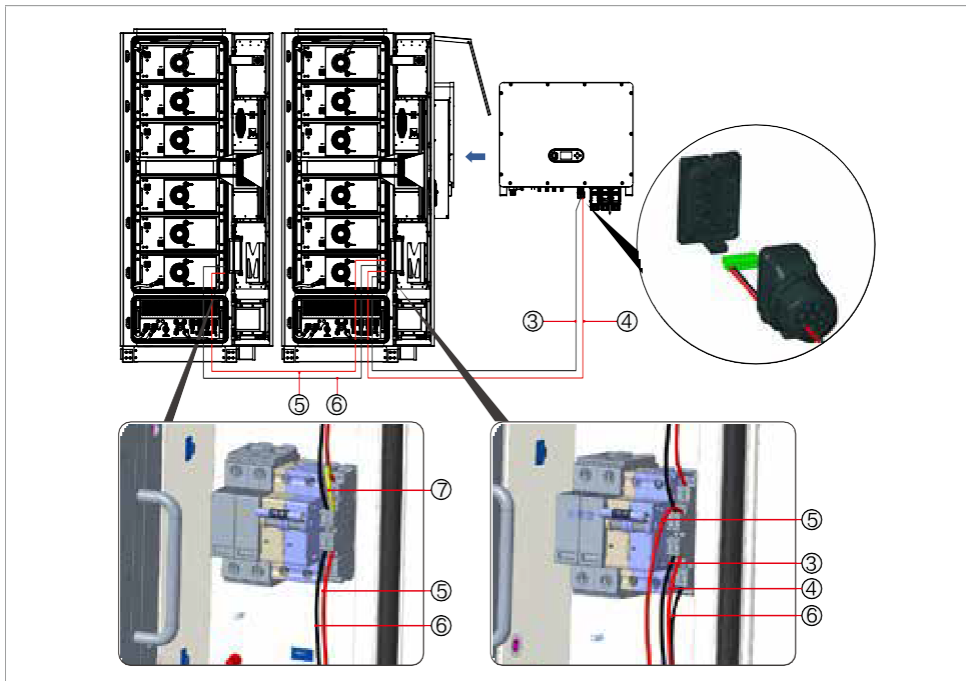

10.2 POST-WIRING OPERATIONS

After completing all electrical connections, a thorough and careful inspection must be carried out. In addition, the following actions are required:

- ▶ Seal the cable outlet holes of the energy storage cabinet and any surrounding gaps using fireproof and waterproof materials.
- ▶ All cover plates, door panels, and screws removed during wiring must be reinstalled and restored to their original positions.

11 POWER-ON OPERATION

11.1 POWER-ON STEPS

1. Turn on the inverter battery port switch.



2. Turn on the cabinet circuit breaker.

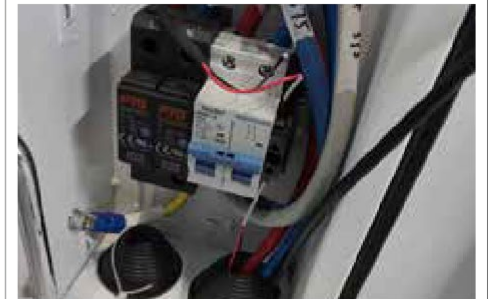

3. Turn on the DC battery switch.



4. Turn on the DC battery switch
Press the BCU ON/OFF start button

