



USER'S MANUAL



AZZURRO HUB

ZSM-HUB



ZUCCHETTI
Centro Sistemi



GREEN
INNOVATION

Azzurro HUB - monitoring and control system

User Manual



Summary

1. Preliminary safety regulations	7
1.1. safety instructions	7
2. Product features	10
2.1. Product presentation.....	10
2.2. Local web server	10
2.3. Communication with devices	10
2.4. Communication with the portal	10
2.5. General product description	11
2.6. 14-PIN COM connector [A]	13
2.7. 4-pin output connector [A1].....	14
2.8. 10-pin output connector [A2].....	14
2.9. 12-PIN output connector [B]	15
2.10. Power supply connector [E]	15
2.11. Ethernet connector [D].....	15
3. installation diagrams	16
3.1. System diagram with ZCS inverter for storage.....	17
3.2. System diagram with ZCS pure photovoltaic 3PH inverter	18
3.3. System diagram with ZCS HUB ---EMSc.....	19
3.4. System diagram with ZCS Power Magic	20
3.5. System diagram with sensors (TA) connected directly to the Azzurro HUB	21
4. Connection to external devices	22
4.1. Connection to VITA series charging stations.....	22
4.2. Connection to CARO series charging stations.....	24
4.2.1. Software configuration - CARO series.....	30
4.3. Connection to ZCS V3-HYD 3PH series inverter	35
4.4. Connection to ZCS ZP1 series inverters (One and All)	37
4.5. Connection to ZCS HP series inverters	38



- 4.6. Connection to ZCS BZT5000 series inverters39
- 4.7. Connection to ZCS ZP3 series inverters (One and All)40
- 4.8. Connection to ZCS 3PH and 1PH meters (ZSM-METER-DDSU/ ZSM-METER-DTSU).....41
- 4.8.2. ZSM-METER-DTSU meter settings.....44
- 5. First start-up and configuration of Azzurro HUB47
 - 5.1. Step 1 – Connection to Access Point.....47
 - 5.2. Step 2 – Guided configuration via wizard48
 - 5.2.1. Step 3 - Internal clock and connectivity49
 - 5.2.2. Step 4 - Wi-Fi network connection.....50
 - 5.2.3. Step 5 - Connectivity test52
 - 5.2.4. Step 6 - System53
 - 5.2.5. Step 7 - Connected devices56
 - 5.2.6. Step 8 - 0 input function.....57
 - 5.2.7. Step 9 - Inverter connection standard selection.....58
 - 5.2.8. Step 10 - End of procedure59
- 6. Uninstallation.....60
 - 6.1. Uninstallation steps.....60
 - 6.2. packaging.....60
 - 6.3. Storage60
 - 6.4. Disposal60
- 7. warranty terms and conditions.....61

Warnings

This manual contains important safety instructions that must be followed and observed during installation and maintenance of the equipment.

Keep these instructions!

This manual must be considered an integral part of the equipment and must be available at all times to anyone who interacts with the equipment. The manual must always accompany the equipment, even when it is transferred to another user or moved to another installation.

Copyright statement

The copyright of this manual belongs to Zucchetti Centro Sistemi S.p.A. Other companies or individuals are prohibited from copying it, in whole or in part (including software, etc.), reproducing it or distributing it in any form or channel without the consent of Zucchetti Centro Sistemi S.p.A. All rights reserved. ZCS reserves the right of final interpretation. This manual is subject to change based on feedback from users, installers or customers. Please check our website <http://www.zcsazzurro.com> for the latest version.

Technical support

ZCS offers a technical support and consulting service accessible by sending a request directly from the website www.zcsazzurro.com

For the United Kingdom, the toll-free number is: 0800 020 2222.

Preface

General information

Please read this manual carefully before installation, use or maintenance. This manual contains important safety instructions that must be followed during installation and maintenance of the equipment.

Scope



This manual describes the assembly, installation, electrical connections, commissioning, maintenance and troubleshooting of the "Azzurro HUB" system. Keep this manual handy so that it is accessible at all times.

Intended audience

This manual is intended for qualified technical personnel (installers, technicians, electricians, technical support personnel or anyone qualified and certified to work on electrical systems) responsible for installation and commissioning. The manual is also intended for end users who may find useful information on managing their system via the "Azzurro-HUB" system.

Symbols used

This manual provides information on how to work safely and uses certain symbols to ensure the safety of personnel and materials and for efficient use during normal operation. It is important to understand this information to avoid accidents and damage to property. Please familiarise yourself with the symbols shown below and used in this manual.

	Danger: indicates a hazardous situation which, if not resolved or avoided, could result in serious personal injury, injury or death.
Danger	
	Warning: indicates a hazardous situation which, if not corrected or avoided, could result in serious personal injury, injury or death.
Warning	
	Caution: indicates a hazardous situation which, if not avoided or corrected, could result in minor or moderate personal injury
Caution	

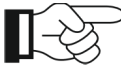
	<p>Caution: indicates a potentially hazardous situation which, if not corrected or avoided, could result in damage to the equipment, objects or other elements</p>
<p>Caution</p>	
	<p>Note: important suggestions for the correct and optimal operation of the product</p>
<p>Note</p>	

1. Preliminary safety regulations



Note

If you have any doubts or difficulties in reading and understanding the following information, please contact Zucchetti Centro Sistemi S.p.A. through the official channels provided.

1.1. safety instructions

This section mainly introduces the safety instructions to be followed during installation and use of the equipment.

Read and understand the instructions in this manual and familiarise yourself with the relevant safety symbols in the chapter; only then should you begin to install and operate the equipment. All installation work must be carried out by a qualified and competent electrician.

Contact your nearest authorised service centre if any repairs or maintenance are required. Contact your distributor for information on your nearest authorised service centre. **DO NOT** attempt to repair the equipment yourself; doing so may result in injury or damage.

Qualified personnel

Ensure that the operator has the necessary skills and training to perform their duties. Personnel responsible for the use and maintenance of the equipment must be competent, knowledgeable and familiar with the activities described, as well as having the appropriate knowledge to correctly interpret the contents of this manual. For safety reasons, only a qualified electrician who has received the necessary training and/or has demonstrated the necessary skills and knowledge in the installation and maintenance of the device may install this system. Zucchetti Centro Sistemi S.p.A. declines all responsibility for damage to property or personal injury caused by incorrect use of the device.

Do not attempt to repair or replace any components of the system without qualified personnel.

Installation requirements



Install and start up the system according to the following instructions. Choose a suitable location for the installation of electrical equipment. Ensure there is sufficient space to facilitate any maintenance work.

Transport requirements

If you find any problems with the packaging that could cause damage to the system, or if there is visible damage, please contact the transport company responsible immediately. If necessary, seek assistance from an installer or Zucchetti Centro Sistemi S.p.A. The equipment must be transported, especially by road, using means that are suitable for protecting the components (in particular the electronic components) from violent shocks, humidity, vibrations, etc.



Electrical connections

All applicable electrical regulations regarding accident prevention must be observed.

	<p>Before connecting to the power supply, ensure that the voltage on the AC connection cables is properly isolated.</p>
Danger	
	<p>All installation work must be carried out exclusively by a professional electrician!</p> <p>They must be trained and must carefully read this manual and understand the relevant topics.</p>
Warning	
	<p>It is forbidden to remove the information label or tamper with the system</p> <p>Otherwise, ZCS will not provide any warranty or assistance.</p>
Note	

Operation

Do not use the product if it is defective, cracked, abraded or leaking. Contact your dealer or our staff.

	<p>Contact with the mains or the equipment terminal may cause electric shock or fire!</p> <ul style="list-style-type: none"> • Do not touch the terminal or conductor connected to the mains. • Pay attention to all instructions and safety documents relating to connection to the mains.
Danger	
	<p>If the operation is abnormal:</p> <ul style="list-style-type: none"> • Disconnect the power supply input and output.
Warning	

Maintenance and repair

Keep the system clean and dry; if cleaning is necessary, use a clean, dry cloth.

Product label:



2. Product features

2.1. Product presentation

Azzurro HUB is a control system that can communicate with Azzurro series electric vehicle charging stations and Azzurro series photovoltaic and hybrid inverters. It can also measure consumption, monitor systems, limit the power fed into the grid and control domestic loads through the use of accessory sensors, external meters and digital outputs.

2.2. Local web server

When switched on, Azzurro HUB emits a Wi-Fi/BT access point to which you can connect by scanning the QR code on the product.

After connecting to the access point, the web server for product configuration will open automatically. It can also be accessed at the IP address 192.168.20.1:55560.

After the first connection to the router (eth or Wi-Fi), the web server can also be accessed by entering the IP address assigned by the router in a browser using port 55560 (e.g. 192.168.1.100:55560).

2.3. Communication with devices

Communication with vehicle charging stations can be carried out, depending on the model, via the dedicated CAN serial port for up to a maximum of 8 devices (VITA series Wallbox), via the RS485 serial port for 32 devices (Caro series Wallbox) or via Modbus TCP (DC series Wallbox) for up to a maximum of 32 devices.

Communication with inverters can be carried out via a dedicated RS485 serial port, with up to 32 inverters connected to Azzurro HUB.

Communication with the meters can be achieved via a dedicated RS485 serial port. Up to 32 meters can be connected to the Azzurro HUB.

2.4. Communication with the portal

To communicate with the web portal/mobile app, you need an internet connection to connect Azzurro HUB.

Azzurro HUB can be connected to any router via the RJ45 connector on the top of the device or via WiFi connection.

2.5. General product description

Azzurro HUB can be installed on a DIN rail (6 modules) and powered by a 230V AC mains supply. Its connections allow the connection of accessories, charging stations, Azzurro series inverters and the necessary power supplies.

There are two hardware versions of the Azzurro, named:

- **Ver.A;**
- **Ver.B**

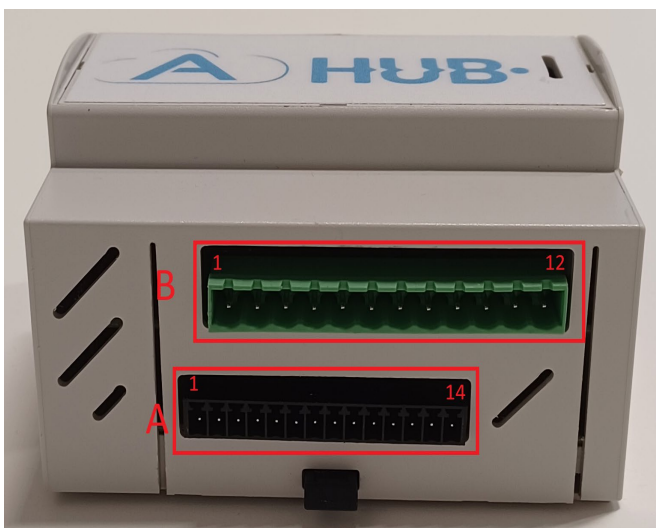

Figure 2 – Bottom view of **Ver.A** device

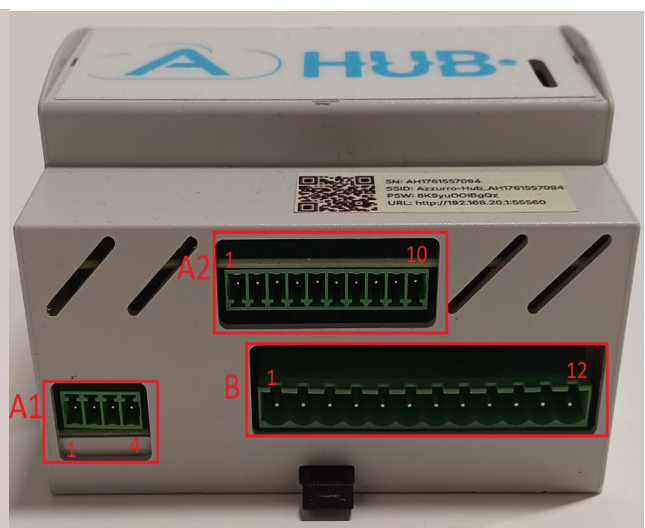

Figure 2 – Bottom view of **Ver.B** device

The system has a 14-pin terminal block (A) at the bottom for connecting devices (inverters, meters, wallboxes, etc.) and a 12-pin terminal block (B) for outputs (relay - dry contact).

The bottom part of the system has two terminal blocks, one with 4 pins (A1) and the other with 10 pins (A2) for connecting devices (inverters, meters, wallboxes, etc.) and a 12-pin terminal block (B) for outputs (relay - dry contact).

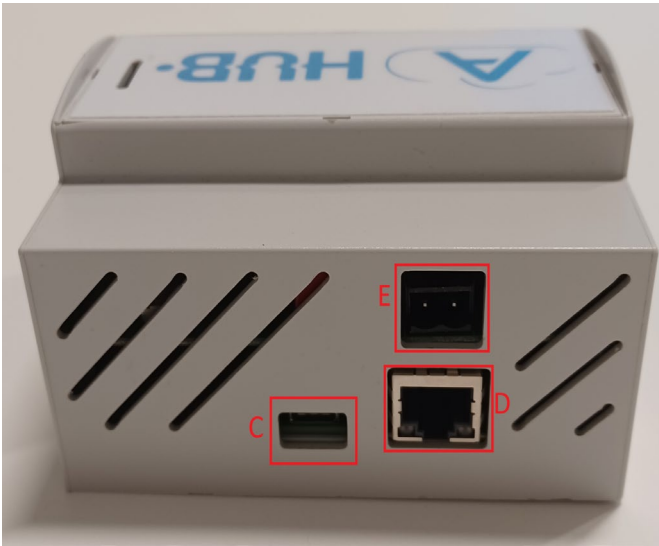

Figure 3 - Top view of Device **Ver.A**

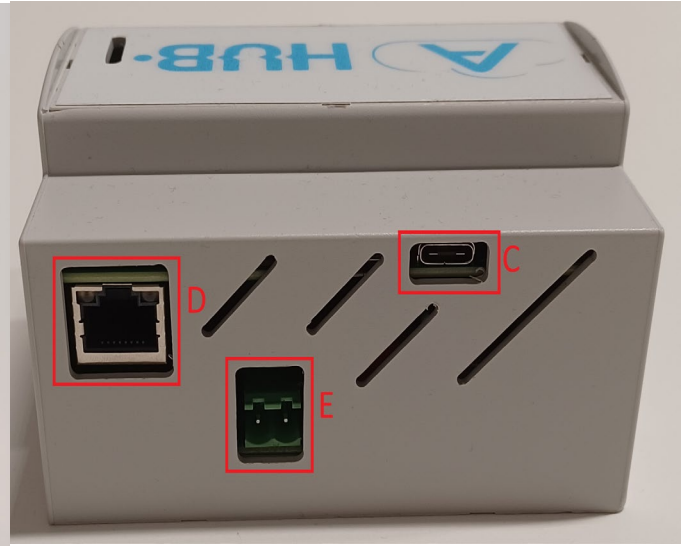

Figure 3 - Top view of Device **Ver.B**

The following are located at the top:
 the 230V AC power connector [E].
 the USB-C connector [C] for future expansions,
 the RJ45 connector [D] for Ethernet connection

The following are located on the top:
 the RJ45 connector [D] for Ethernet connection
 the USB-C connector [C] for future expansions,
 the 230V AC power connector [E].

2.6. 14-PIN COM connector [A]

Pinout of the **14-pin** connector [A]:

PIN Light blue HUB [A]	Description of Azzurro HUB pins [A]	Description of associated external device	Connector on external device	Pin on external device
1	CAN-L	CAN wall box	RJ45 for CAN connection	5
2	CAN-H	CAN wall box	RJ45 for CAN connection	4
3	Analogue input 1+	PT100/PT1000 temperature probe	/	/
4	Analogue input 1-	PT100/PT1000 temperature probe	/	/
5	CT exchange +	current sensor for exchange point, transformation ratio 3000:1 (max 80A on primary)	/	/
6	Exchange CT -	current sensor for exchange point, transformation ratio 3000:1 (max 80A on primary)	/	/
7	CT production +	current sensor for external production, transformation ratio 3000:1 (max 80A on primary)	/	/
8	CT production -	current sensor for external production, transformation ratio 3000:1 (max 80A on primary)	/	/
9	RS485 3A	External meter	RS485	24
10	RS485 3B	External meter	RS485	25
11	RS485 2A	CARO series wallbox	RS485	RS485 A
12	RS485 2B	CARO series wallbox	RS485	RS485 B
13	RS485 1A	Azzurro V3 or HYD 3PH series inverter	COM	1-2
		Azzurro HYD 1PH HP series inverter	COM	5
		Azzurro HYD 1PH ZP1 series inverter	COM	2
14	RS485 1B	Azzurro V3 or HYD 3PH series inverter	COM	3-4
		Azzurro HYD 1PH HP series inverter	COM	6
		Azzurro HYD 1PH ZP1 series inverter	COM	3

2.7. 4-pin output connector [A1]

Pinout of the **4-pin** connector [A1]:

PIN Light blue HUB [A]	Description of Azzurro HUB [A] pins	Description of associated external device	Connector on external device	Pin on external device
1	CT exchange +	current sensor for exchange point transformation ratio 3000:1 (max 80A on primary)	/	/
2	CT exchange -	current sensor for exchange point, transformation ratio 3000:1 (max 80A on primary)	/	/
3	CT production +	current sensor for exchange point, transformation ratio 3000:1 (max 80A on primary)	/	/
4	CT production -	current sensor for exchange point, transformation ratio 3000:1 (max 80A on primary)	/	/

2.8. 10-pin output connector [A2]

Pinout of the **10-pin** connector [A2]:

PIN Light blue HUB [A]	Description of Azzurro HUB pins [A]	Description of the associated external device	Connector on external device	Pin on external device
1	Analogue input 1+	PT100/PT1000 temperature probe	/	/
2	Analogue input 1-	PT100/PT1000 temperature probe	/	/
3	RS485 1A	Azzurro V3 or HYD 3PH series inverter	COM	1-2
		Azzurro HYD 1PH HP series inverter	COM	5
		Azzurro HYD 1PH ZP1 series inverter	COM	2
4	RS485 1B	Azzurro V3 or HYD 3PH series inverter	COM	3-4
		Azzurro HYD 1PH HP series inverter	COM	6
		Azzurro HYD 1PH ZP1 series inverter	COM	3

5	RS485 3A	External meter	RS485	24
6	RS485 3B	External meter	RS485	25
7	RS485 2A	Wallbox CARO series	RS485	RS485 A
8	RS485 2B	Wallbox CARO series	RS485	RS485 B
9	CAN-H	CAN wall box	RJ45 for CAN connection	5
10	CAN-L	CAN wall box	RJ45 for CAN connection	4

2.9. 12-PIN output connector [B]

PIN Light blue HUB [B]	Description of Blue HUB [B] pins	1. Rating
1	Relay output 1 NC	3A / 230V AC 3A / 48V DC
2	Relay output 1 COM	
3	Relay output 1 NO	
4	Relay output 2 NC	
5	Relay output 2 COM	
6	Relay output 2 NO	
7	Relay output 3 NC	
8	Relay output 3 COM	
9	Relay output 3 NO	
10	Relay output 4 NC	
11	Relay output 4 COM	
12	Relay output 4 NO	

Cables with a maximum recommended cross-section of 1.5mm^2 can be connected to this connector.

2.10. Power supply connector [E]

A 230V 50Hz power supply can be connected to this connector; the maximum recommended cable cross-section is 1.5mm^2 .

2.11. Ethernet connector [D]



The Ethernet connector, equipped with two LEDs, allows for wired network connection. All Azzurro HUB devices are already set up for connection via both on-board WiFi and cable.

3. installation diagrams

This chapter describes the electrical connections of the system.

Read this section carefully before connecting the cables.

During installation, repair and maintenance of the product, local, regional and national regulations must be observed.

	<p>Before making electrical connections, ensure that there is no AC current. Zucchetti Centro Sistemi Spa accepts no responsibility for consequences resulting from the improper use of this product. Installation must be carried out by a qualified professional with the skills and knowledge related to the construction, installation and operation of electrical components and who has received safety training to recognise and avoid potential hazards.</p>
Warning	
	<p>Installation and maintenance must be carried out by professional technicians or electricians.</p>
Warning	

	<p>For safety reasons, ensure that correctly sized cables are used, otherwise the current may cause excessive heating or overloads, which could lead to fire.</p>
Note	

Cable connection procedure

- 1) Before starting any operation, ensure that you are working in safe conditions by checking that there is no voltage on the cables.
- 2) Remove the protective sheath to the appropriate length as shown in the figure (A: 80~100 mm B: 6~8 mm);

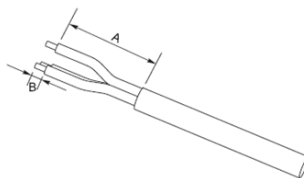

Figure 4 - Connection of AC power cables

- 3) Connect the cable to the dedicated input (connector E – see chapter 2).

3.1. System diagram with ZCS inverter for storage

INVERTER TYPE	COMPATIBLE INVERTER MODEL
1PH	BZT5000 - Retrofit
1PH	HYD 3000-ZSS HP/HYD 6000-ZSS HP
1PH	HYD3000 HYD6000 ZP1 – One and All
3PH	HYD5000 HYD12000 ZP3 – One and All
3PH	HYD 5000 ZSS/HYD 20000 ZSS

The diagram below is recommended when the system includes one or more storage inverters (1PH or 3PH) from the ZCS Azzurro range shown in the table above.

- ZCS pure photovoltaic inverters can be connected via RS485 to the Azzurro HUB for monitoring and control functions (e.g. zero feed-in).
- Pure photovoltaic inverters from other brands can be monitored with a special external production meter connected to the master hybrid inverter (EXT Production Meter).
- Select the exchange measurement mode: Master hybrid inverter

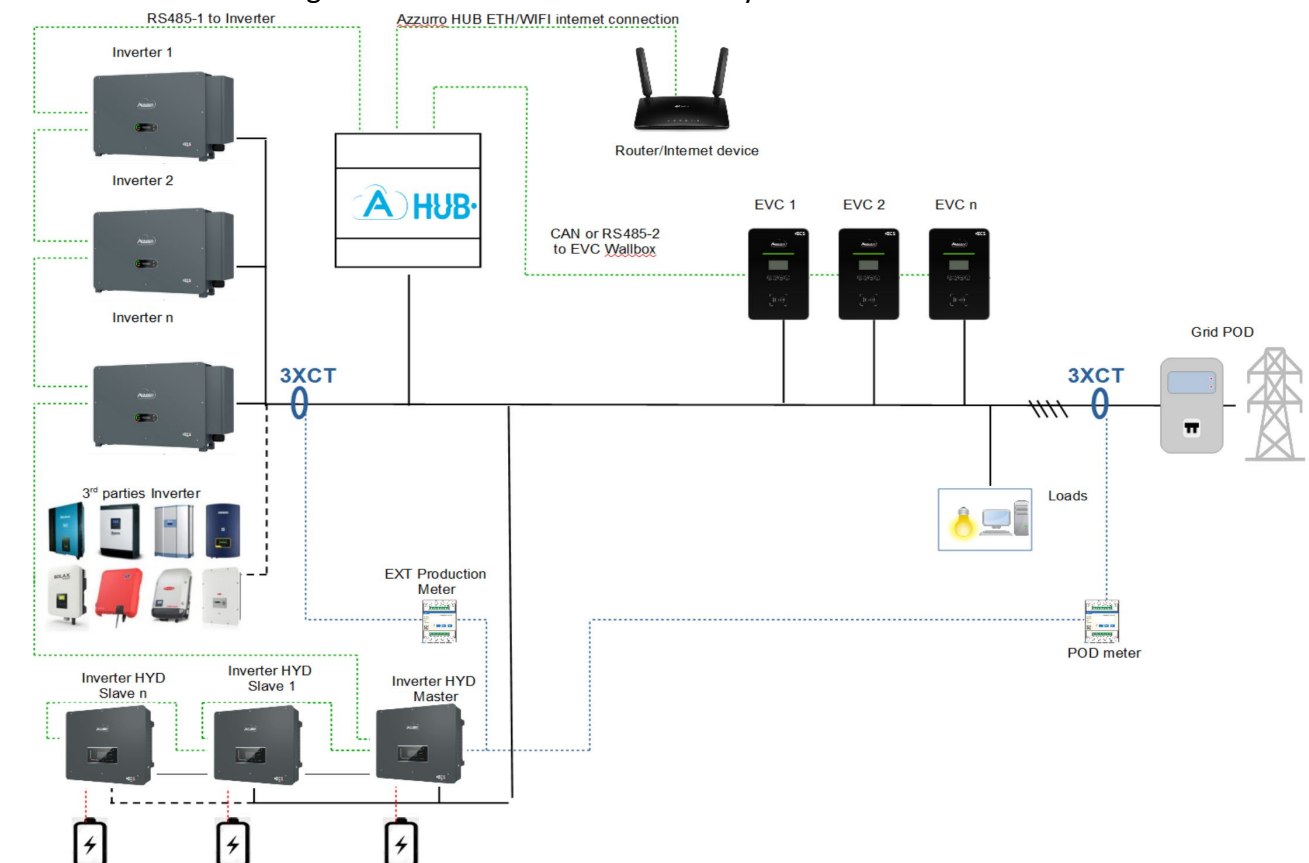

Figure 5 - System diagram with one or more hybrid inverters

3.2. System diagram with ZCS pure photovoltaic 3PH inverter

INVERTER TYPE	COMPATIBLE INVERTER MODEL
3PH	3.3KTL-V3/3PH 12KTL-V3
3PH	15000TL-V3/3PH 24000TL-V3
3PH	25KTL-V3/3PH 50KTL-V3
3PH	60KTL-V3/3PH 80KTL-V3
3PH	80KTL-LV/110KTL-LV
3PH	100KTL-V4/110KTL-V4
3PH	100KTL-HV/136KTL-HV
3PH	250KTL-HV/255KTL-HV
3PH	250KTL-HV Z0 / 330KTL-HV Z0 / 350KTL-HV Z0

Use this diagram when the system includes photovoltaic inverters (3PH) from the ZCS Azzurro range indicated in the table above.

NOTES:

- Pure photovoltaic inverters from other brands can be monitored via the external production meter connected to Azzurro HUB (EXT Production Meter).
- Select the exchange measurement mode: Meter

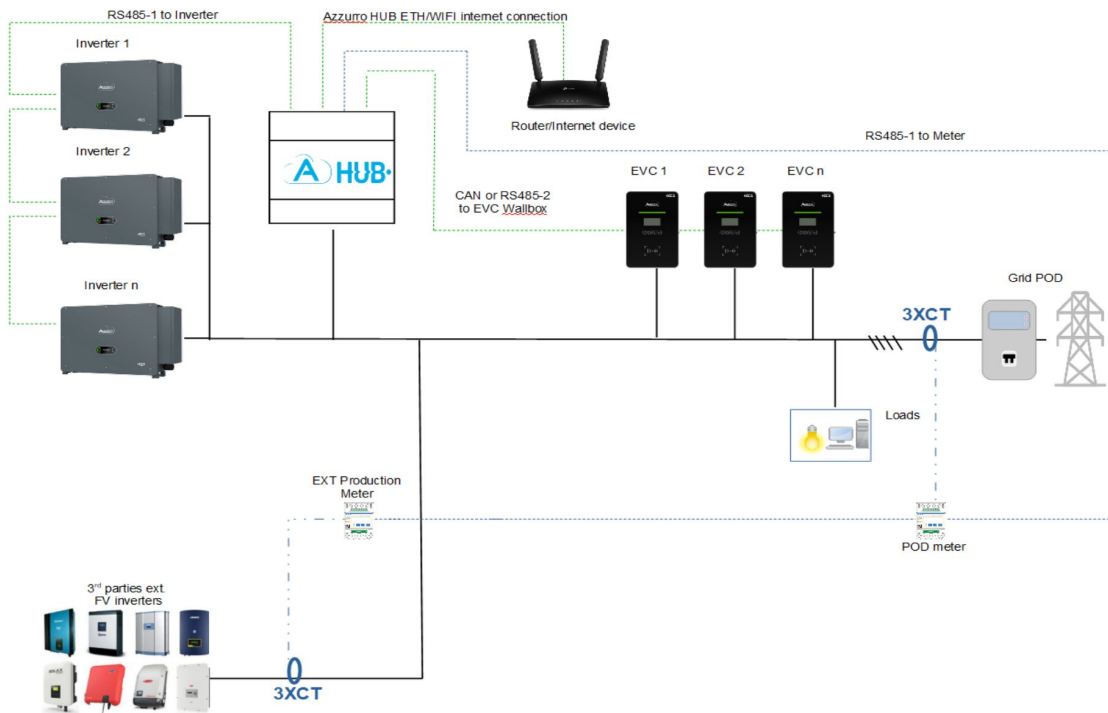

Figure 6 - System diagram with one or more 3PH pure photovoltaic inverters

3.3. System diagram with ZCS HUB ---EMSc

NOTES:

- Inverters from other brands can be monitored with the external production meter connected to the Power Magic Master (EXT Production Meter)
- Select the exchange measurement mode: EMS
- In this mode, the master/slave connection is not necessary

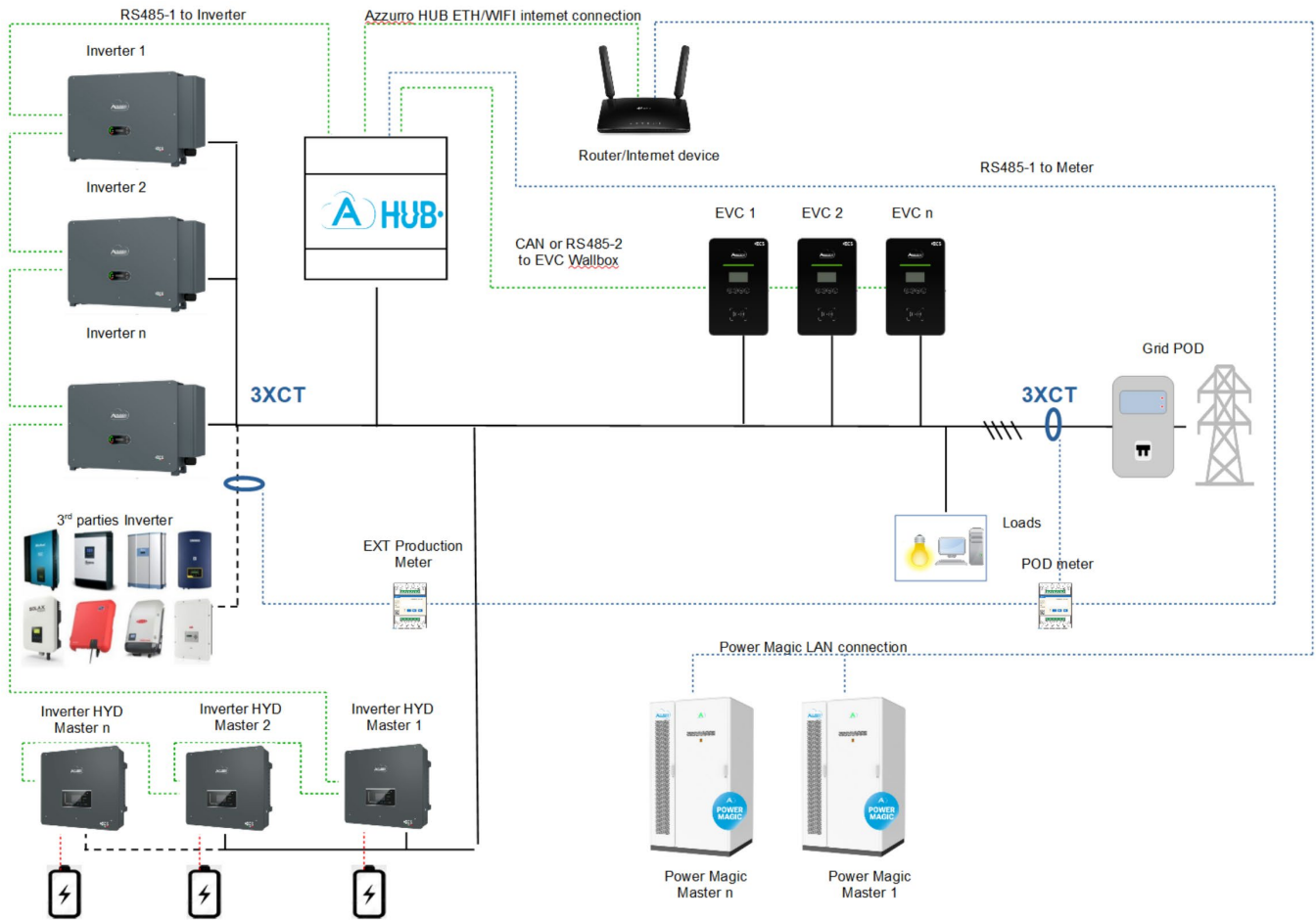

Figure 7 - EMSc System Diagram

3.4. System diagram with ZCS Power Magic

NOTES:

- Inverters from other brands can be monitored with the external production meter connected to the Power Magic Master (EXT Production Meter)
- Select the Exchange Measurement mode: Power Magic

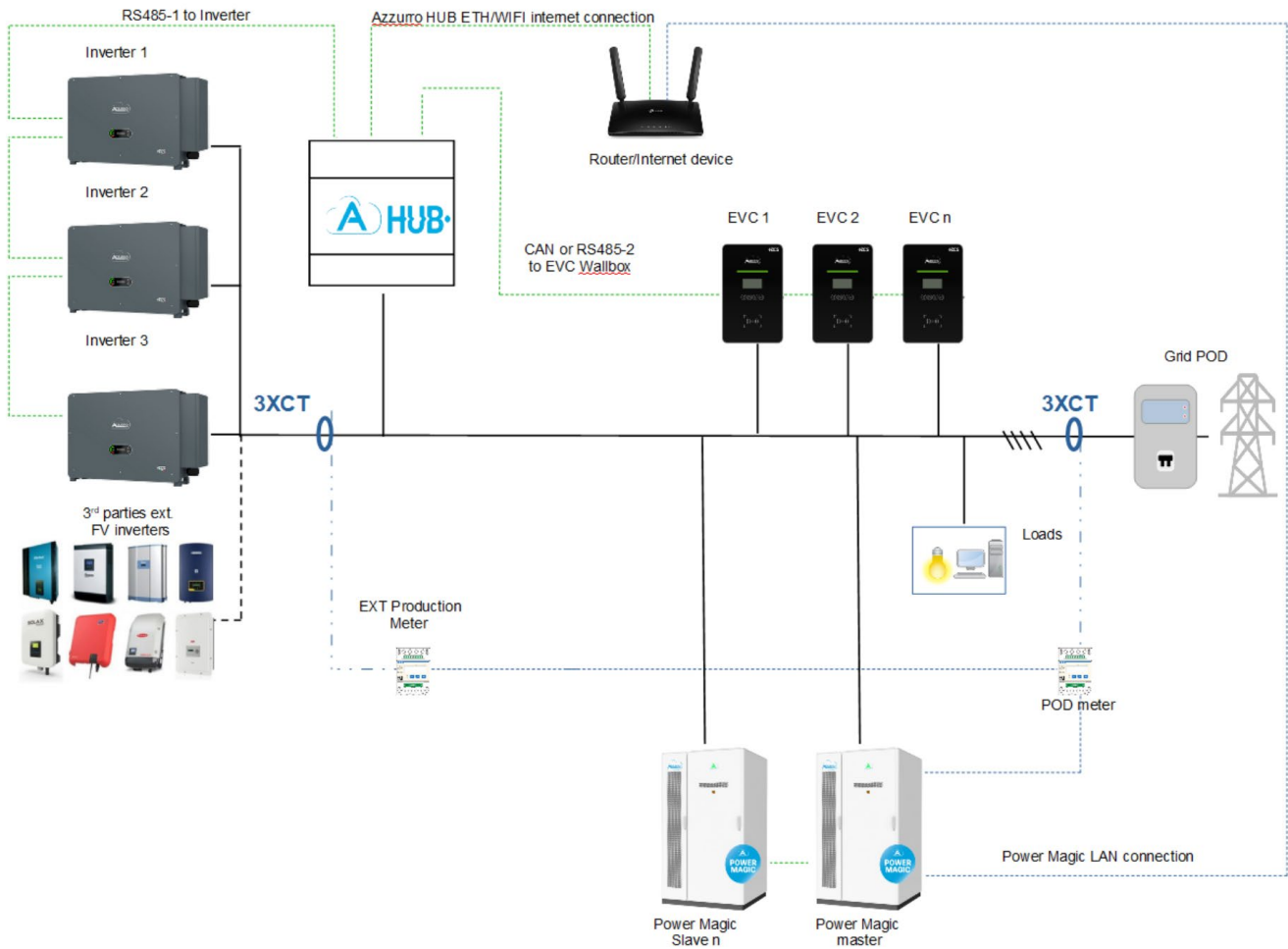

Figure 8 - POWER MAGIC System Diagram

3.5. System diagram with sensors (TA) connected directly to the Azzurro HUB

This solution can only be used on single-phase (1PH) systems, using sensors (TA) with a 3000:1 transformation ratio supplied by ZCS (e.g. ZST-ACC-TA).

1. Pure photovoltaic inverters from other brands can be monitored with the sensor (EXT Production)
2. Select the exchange measurement mode: Internal Sensors

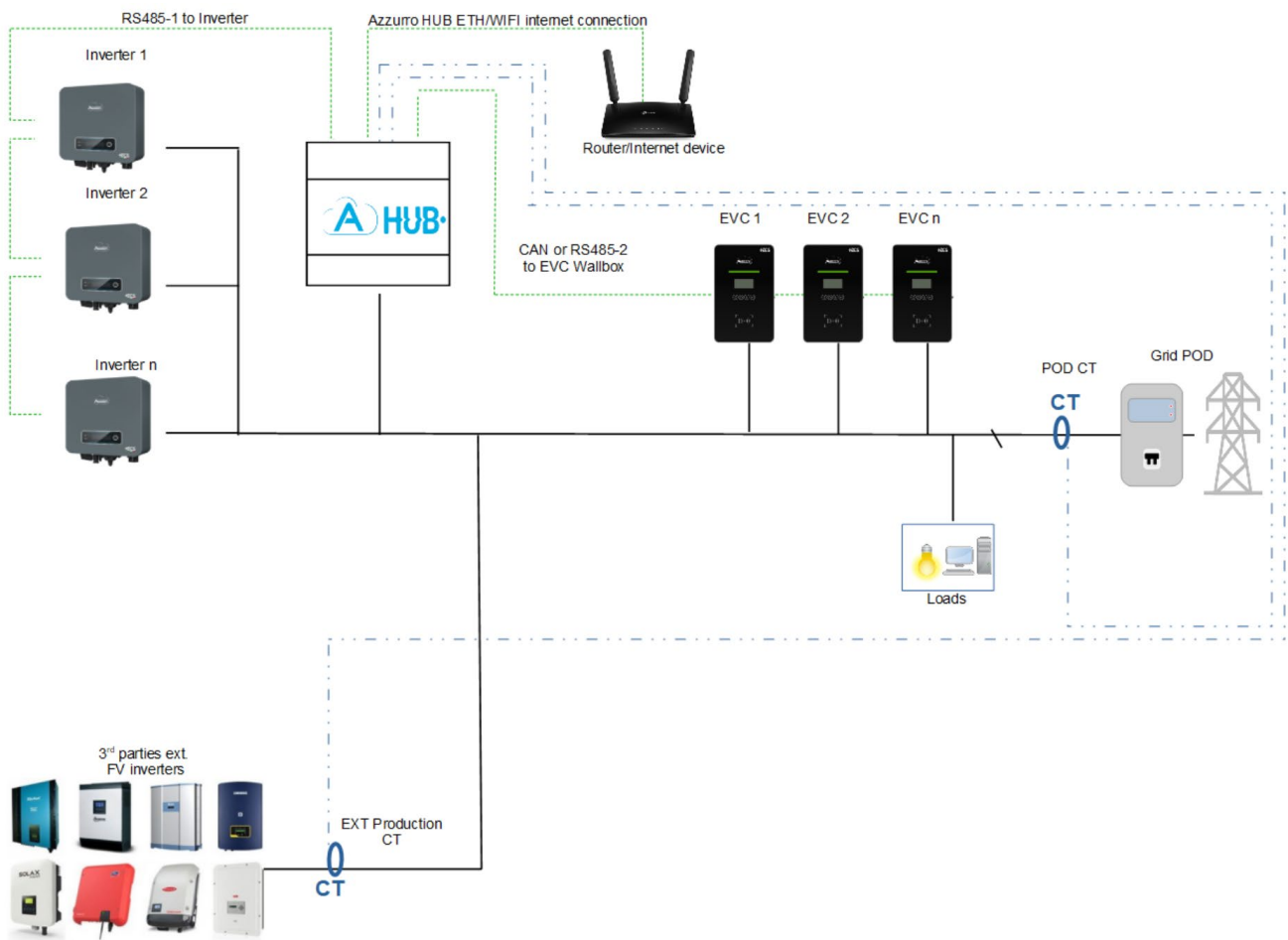



Figure 9 - System Diagram SENSORS connected directly to the Azzurro HUB

4. Connection to external devices

4.1. Connection to VITA series charging stations

	TYPE OF EV CHARGER	COMPATIBLE EV CHARGER MODEL	Azzurro HUB PIN [A]	Light blue PIN HUB [A1]
	1PH	7KW EV CHARGER	EV CHARGER 22KW	CAN-L 1 CAN-H 2
3PH				

Up to 8 Azzurro EV charging stations can be connected in series.

The Azzurro HUB must be connected to the first charging station following the instructions provided here.

- 1) Connect the 8-pin cable to the ports marked CAN port in the figure below using an RJ45 connector.
- 2) For clarity, the pin-out of the RJ45 connector is shown in **the figure below**.

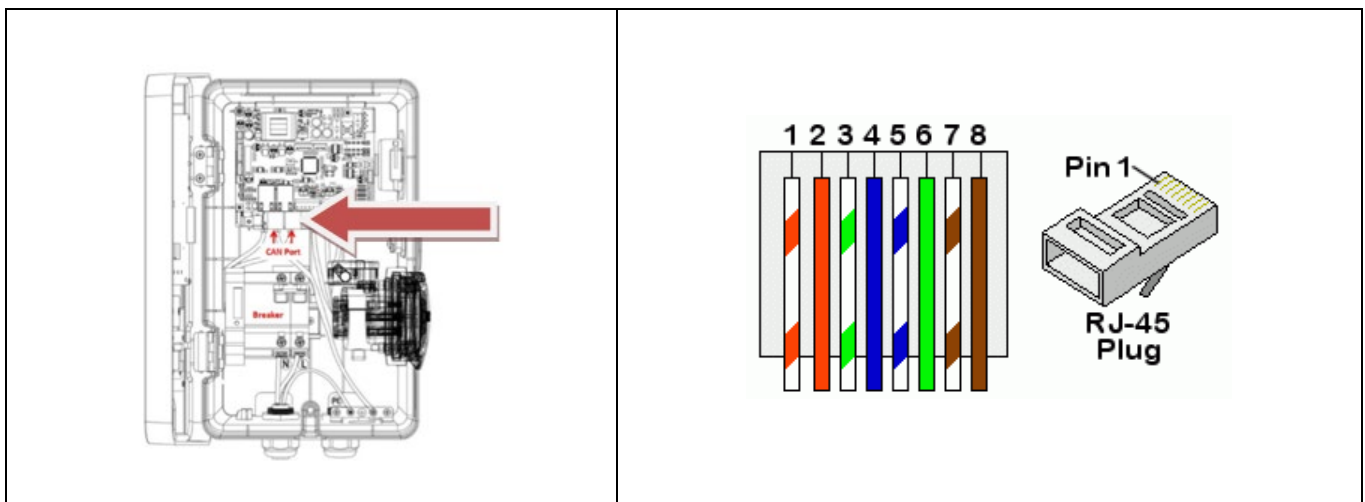

3) Connect the prepared wiring according to the following diagram.

RJ45 pin VITA	Cable colour	Signal description	PIN Light blue HUB [A]	Light blue PIN HUB [A1]
4	Blue	CAN-H	1	9
5	White-Blue	CAN -L	2	10

4) Connect any other wallboxes in cascade using the RJ45 connectors of the CAN ports as "input-output". Only the first wallbox is connected to the Azzurro HUB.

	<p>Note on RS-485 cabling</p> <p>Only use certified twisted pair shielded cables for RS-485 communications for the connection.</p> <p>The shielding must be grounded at only one end of the cable (typically the master/main device side) to avoid ground loops and reduce electromagnetic interference.</p>
Note	

Set the wallbox display to Plug&Play.

4.2. Connection to CARO series charging stations

	EVCHARGER TYPE	COMPATIBLE EV CHARGER MODEL	Blue PIN HUB [A]	Blue PIN HUB [A1]
	1PH	EV CHARGER 7KW	EV CHARGER 11KW	RS485 2A 11
3PH	EV CHARGER 11KW	RS485 2B 12		RS485 2B 8

Connect the 2-pole cable to the charging station port. Follow the polarity shown in the figure and the pinout in the table above.

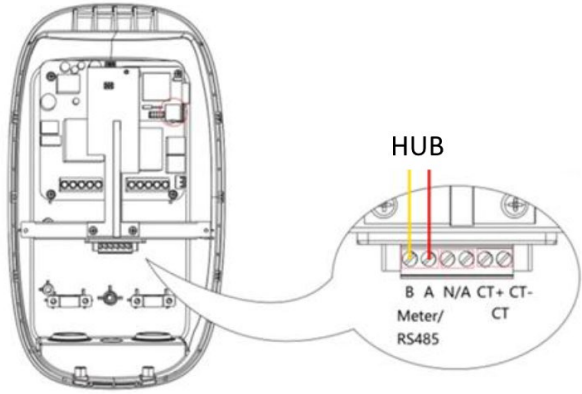
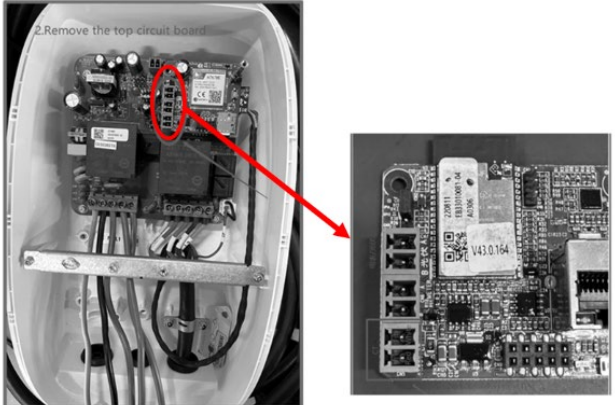
<p>VERSION 'A'</p>	
<p>VERSION 'B'</p>	 <div style="display: flex; align-items: center; margin-left: 20px;"> <div style="border: 1px solid black; padding: 2px; margin-right: 5px;">A</div> AZZURRO HUB <div style="border: 1px solid black; padding: 2px; margin-right: 5px;">B</div> NOT USED <div style="border: 1px solid black; padding: 2px; margin-right: 5px;">CT</div> CT </div>

STEP 1

Loosen the two screws with a flat screwdriver (flat head: 2 mm).

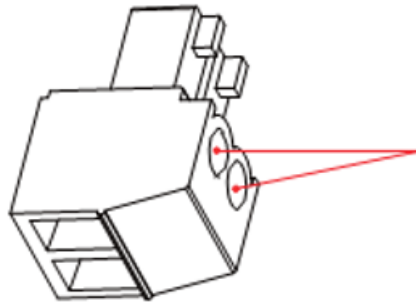

STEP 2

Insert the brown cable and black cable into the corresponding holes.

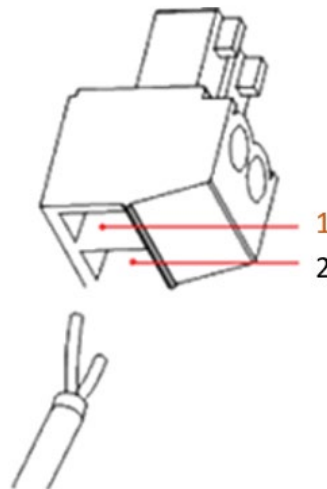

1	Brown cable
2	Black cable

STEP 3

Tighten the two screws with the flat screwdriver (flat head size: 2 mm) to crimp the two conductors.

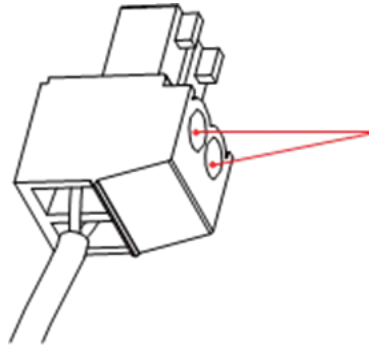

STEP 4

Unscrew the waterproof cap and remove the rubber cap.

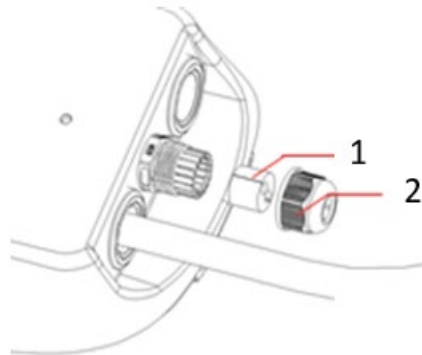

1	Cable gland
2	Waterproof ring nut

STEP 5

Pass the cable connected to the meter connector through the cable gland.

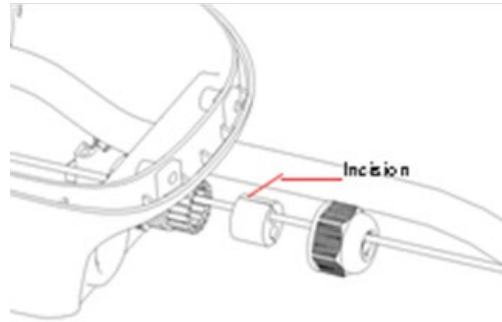

STEP 6

Tighten the ring nut

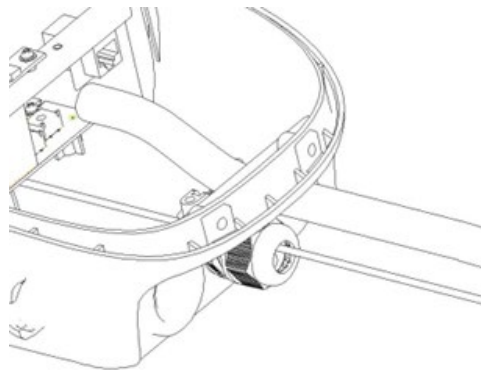

Open the front cover and remove the turret shown in the figure.



Once the turret has been unscrewed, lift the board slightly so that the connector can be inserted into the pins shown



Make the connection on the marked terminal

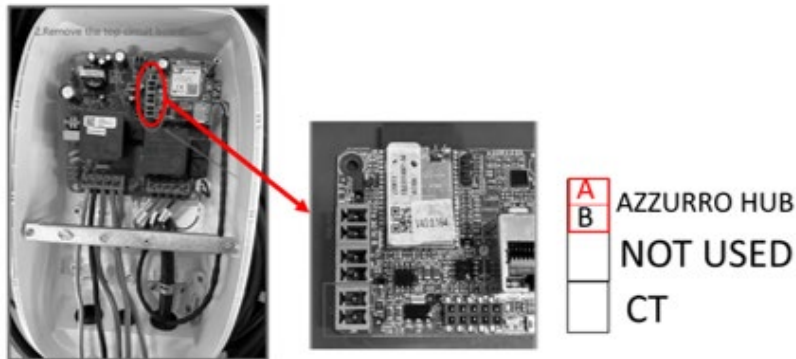

Cable colour	Connection	Blue PIN HUB [A]	Light blue HUB pin [A1]
RED	RS485-A	11	7
BLACK	RS485-B	12	8



Note

Note on RS-485 wiring

Only use cables certified for RS-485 communications, with twisted pair shielding, for the connection.

The shielding must be grounded at only one end of the cable (typically on the master/main device side) in order to avoid the formation of ground loops and reduce electromagnetic interference.

4.2.1. Software configuration - CARO series

AP mode, also known as access point mode, is a versatile wireless networking feature that allows devices such as the EV Charger for electric vehicles to function as Wi-Fi access points, establishing a dedicated hotspot.

Users can easily connect their smartphones or other mobile devices to this hotspot and manage the device via a web interface by navigating to a specific IP address, such as 192.168.4.1.

1. Activate the hotspot:

Activate the EV Charger hotspot by restarting the power supply.

The EV Charger hotspot remains available for 15 minutes after restarting the charger.



2. Connect to the charger's hotspot:

Turn on your smartphone's Wi-Fi and connect to the EV Charger hotspot.

If you are unable to connect, try using aeroplane mode.

The Wi-Fi hotspot name begins with the SN number of the EV Charger, i.e. 'SN...'.
The password is **admin123**



3. Access

Open the browser on your smartphone and enter 192.168.4.1 in the address bar.

Log in using the four-digit PIN code found on the last page of the CARO Ev Charger manual or inside the packaging.

After logging in, the function menu will be displayed.

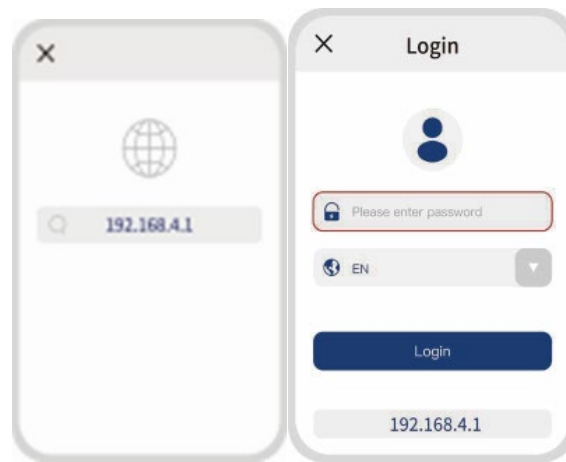

Configuration

Go to 'Charger Settings'.

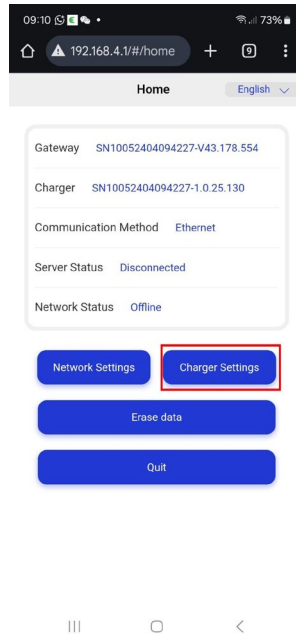

Go to 'Basic Settings'.

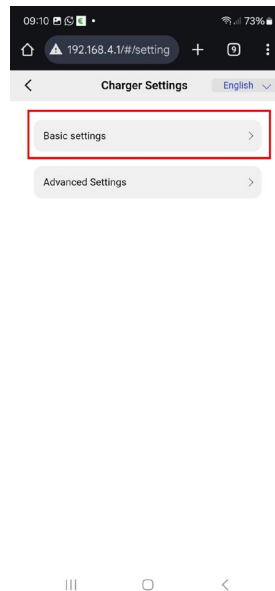

Access 'Charging Modes Switch'

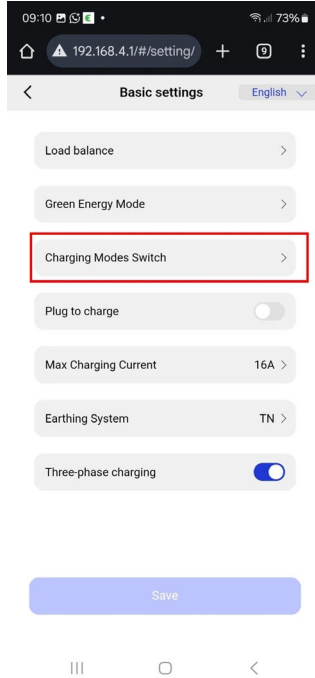

Click on 'EMS'

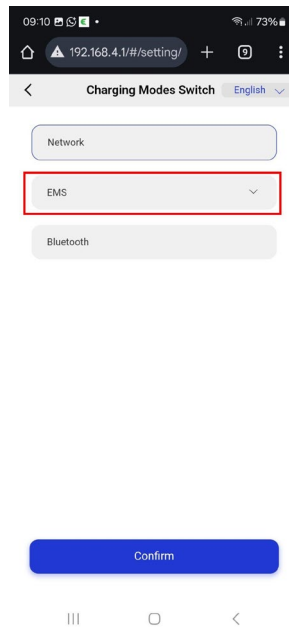

Set the desired Modbus address

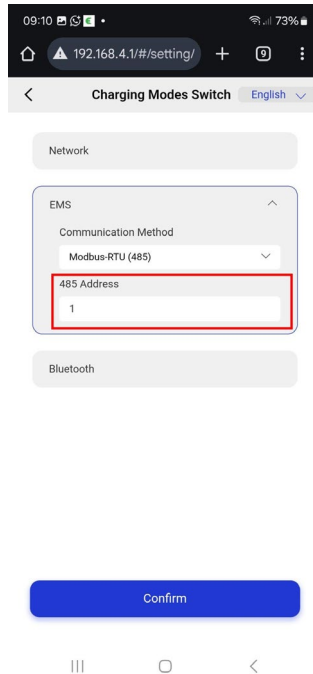

NOTE: If installing multiple EV Chargers, set unique Modbus addresses.

Once finished, click on 'Confirm'

4.3. Connection to ZCS V3-HYD 3PH series inverter

INVERTER TYPE	COMPATIBLE INVERTER MODEL
1PH	1PH 3000TLM-V3/1PH 6000TLM-V3
3PH	3.3KTL-V3/3PH 12KTL-V3
3PH	15000TL-V3/3PH 24000TL-V3
3PH	HYD5000 HYD12000 ZP3 – One and All
3PH	HYD 5000 ZSS/HYD 20000 ZSS
3PH	25KTL-V3/3PH 50KTL-V3
3PH	60KTL-V3/3PH 80KTL-V3
3PH	80KTL-LV/110KTL-LV
3PH	100KTL-V4/110KTL-V4
3PH	100KTL-HV/136KTL-HV
3PH	250KTL-HV/255KTL-HV
3PH	250KTL-HV Z0 / 330KTL-HV Z0 / 350KTL-HV Z0

NOTES: Sensors or meters for measuring exchange must be connected to the inverter according to the manual

To connect the RS485 port to the HYD 5000 ZSS/HYD 20000 ZSS series inverter, connect the 2-pole cable to the hybrid inverter port marked "COM".
Follow the polarity shown in the figure and the pinout in the table.

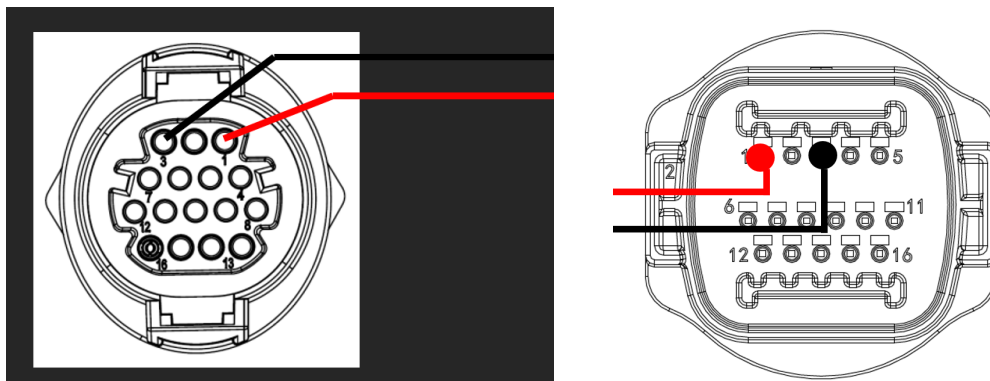

Figure 27 - Connections on COM port (screw and snap-in)

1	Red cable
3	Black cable



Note

Note on RS-485 wiring

Only use cables certified for RS-485 communications, with twisted pair shielding, for the connection.

The shielding must be grounded at only one end of the cable (typically on the master/main device side) in order to avoid the formation of ground loops and reduce electromagnetic interference.

4.4. Connection to ZCS ZP1 series inverters (One and All)

INVERTER TYPE	COMPATIBLE INVERTER MODEL
1PH	HYD3000 HYD6000 ZP1 – One and All

Note: Sensors or meters for measuring exchange must be connected to the inverter according to the manual

To connect the RS485 port to the HYD3000 HYD6000 ZP1 – One and All series inverter, connect the 2-pole cable to the hybrid inverter port marked 'COM'. Follow the polarity shown in the figure and the pinout in the table.

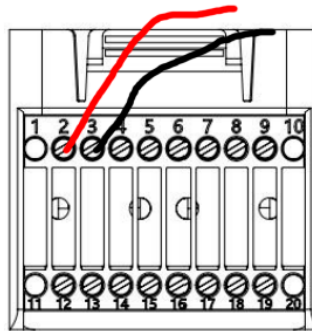



Figure 28 - Connections on the COM port

2	Red cable
3	Black cable

	<p>Note on RS-485 wiring</p> <p>Only use cables certified for RS-485 communications, with twisted pair shielding, for the connection.</p> <p>The shielding must be grounded at only one end of the cable (typically on the master/main device side) in order to avoid the formation of ground loops and reduce electromagnetic interference.</p>
Note	

4.5. Connection to ZCS HP series inverters

INVERTER TYPE	COMPATIBLE INVERTER MODEL
1PH	HYD3000 HYD6000 HP

Note: Sensors or meters for measuring exchange must be connected to the inverter according to the manual.

To connect the RS485 port to a HYD3000-6000 HP series inverter, connect the 2-pole cable to the hybrid inverter port marked 'COM'.

Follow the polarity shown in the figure and the pinout in the table.

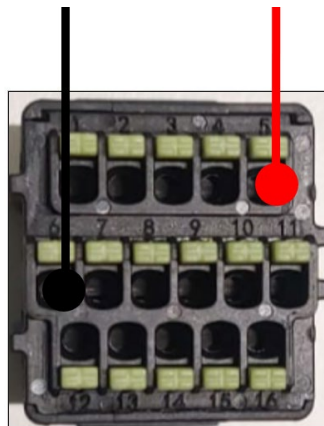



Figure 29 - Connections on the COM port

5	Red cable
6	Black cable

	<p>Note on RS-485 wiring</p> <p>Only use cables certified for RS-485 communications, with twisted pair shielding, for the connection.</p> <p>The shielding must be grounded at only one end of the cable (typically on the master/main device side) in order to avoid the formation of ground loops and reduce electromagnetic interference.</p>
Note	

4.6. Connection to ZCS BZT5000 series inverters

INVERTER TYPE	COMPATIBLE INVERTER MODEL
1PH	BZT5000

Note: Sensors or meters for measuring exchange must be connected to the inverter according to the manual

To connect the RS485 port to a BZT500 series inverter, connect the cable to the hybrid inverter port marked RS485, using the white-orange and orange cables (respectively) PIN 1 and Pin 2 of the RJ45 connector.

Follow the polarity shown in the figure and the pinout in the table.

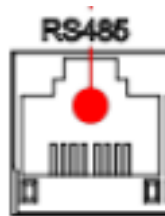
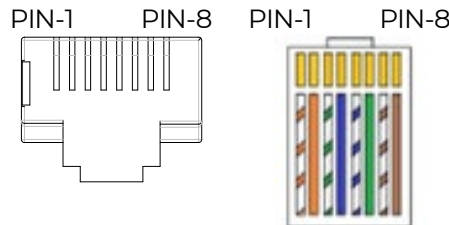



Figure 28 - Connections on COM port



1	White-orange cable	RS485+
2	Orange cable	RS485-

	<p>Note on RS-485 wiring</p> <p>Only use cables certified for RS-485 communications, with twisted pair shielding, for the connection.</p> <p>The shielding must be grounded at only one end of the cable (typically on the master/main device side) in order to avoid the formation of ground loops and reduce electromagnetic interference.</p>
Note	

4.7. Connection to ZCS ZP3 series inverters (One and All)

INVERTER TYPE	COMPATIBLE INVERTER MODEL
3PH	HYD5000 HYD12000 ZP3 – One and All

Note: Sensors or meters for measuring exchange must be connected to the inverter according to the manual

To connect the RS485 port to the HYD5000-12000 ZP3 – One and All series inverter, connect the cable to the hybrid inverter port marked Link0, using the white-orange and orange cables (respectively) PIN 1 and Pin 2 of the RJ45 connector.

Follow the polarity shown in the figure and the pinout in the table.

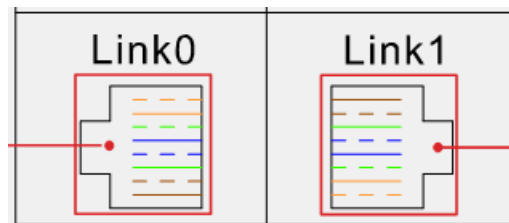
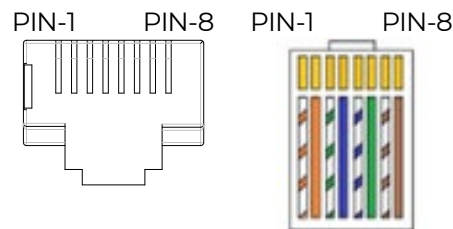



Figure 28 - Connections on COM port



1	White-orange cable	RS485+
2	Orange cable	RS485-

	<p>Note on RS-485 wiring</p> <p>Only use cables certified for RS-485 communications, with twisted pair shielding, for the connection.</p> <p>The shielding must be grounded at only one end of the cable (typically on the master/main device side) in order to avoid the formation of ground loops and reduce electromagnetic interference.</p>
Note	

4.8. Connection to ZCS 3PH and 1PH meters (ZSM-METER-DDSU/ ZSM-METER-DTSU)

METER TYPE	COMPATIBLE METER MODEL
1PH	ZSM-METER-DDSU
3PH	ZSM-METER-DTSU

For RS485 connection to DDSU/DTSU meters, connect the 2-pole cable to the appropriate connector pins.

Follow the polarity shown in the figure and the pinout in the table.

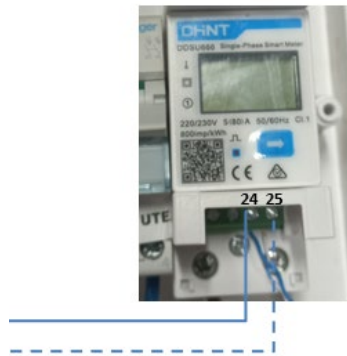



Figure 29 - ZSM-METER-DDSU Meter PIN connections

PIN ZSM-METER- DDSU	Cable colour	PIN BLUE HUB [A]	PIN BLUE HUB [A2]
24	Blue cable	9	5
25	White-blue cable	10	6

	<p>Note on RS-485 wiring</p> <p>Only use cables certified for RS-485 communication, with twisted pair shielding, for the connection.</p> <p>The shielding must be grounded at only one end of the cable (typically on the master/main device side) in order to avoid the formation of ground loops and reduce electromagnetic interference.</p>
Note	

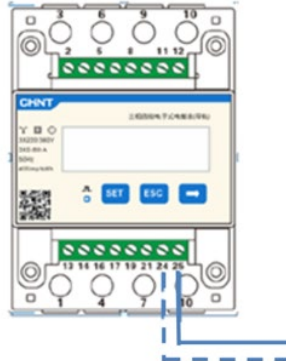



Figure 30 - PIN connections ZSM-METER-DTSU

PIN ZSM-METER- DTSU		PIN BLUE HUB [A]	PIN AZZURRO HUB [A2]
24	Blue cable	9	5
25	White-blue cable	10	6

	<p>Note on RS-485 wiring</p> <p>Only use cables certified for RS-485 communications, with twisted pair shielding, for the connection.</p> <p>The shielding must be grounded at only one end of the cable (typically on the master/main device side) in order to avoid the formation of ground loops and reduce electromagnetic interference.</p>
	<p>Note</p>

4.8.1. ZSM-METER-DDSU meter settings

Connect the meter in "direct insertion" mode as follows:

- ✓ Connect PIN 2 of the meter to the neutral cable (N);
- ✓ Connect PIN 3 to the exchange meter phase;
- ✓ Connect PIN 1 to the photovoltaic system and load direction phase.

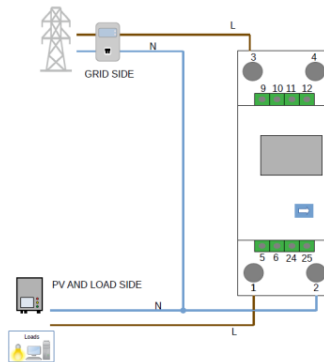

Meter configuration

Press the button  to check that the meter address is set to 001 (address 01 for exchange meters, 002/003/004 for external production meters) and that the protocol is set to 8n1.

4.8.2. ZSM-METER-DTSU meter settings

The power cables for phases R, S, T and the neutral cable (N) are connected to the meter via pins 2, 5, 8 and 10 respectively. The CTs for current measurement are connected:

- Phase R measurement with terminals connected to PIN 1 (red wire) and PIN 3 (black wire)
- Phase S measurement with terminals connected to PIN 4 (red wire) and PIN 6 (black wire).
- Phase T measurement with terminals connected to PIN 7 (red wire) and PIN 9 (black wire).

Position the sensors paying attention to the indication on the sensor itself (arrow).

CAUTION: connect the CTs to the phases only after connecting them to the Meter.

The connection between the Meter and the Azzurro HUB is made via the RS485 serial port. On the Meter side, this port is identified by pins 24 and 25, and on the Azzurro HUB by pins 9 and 10

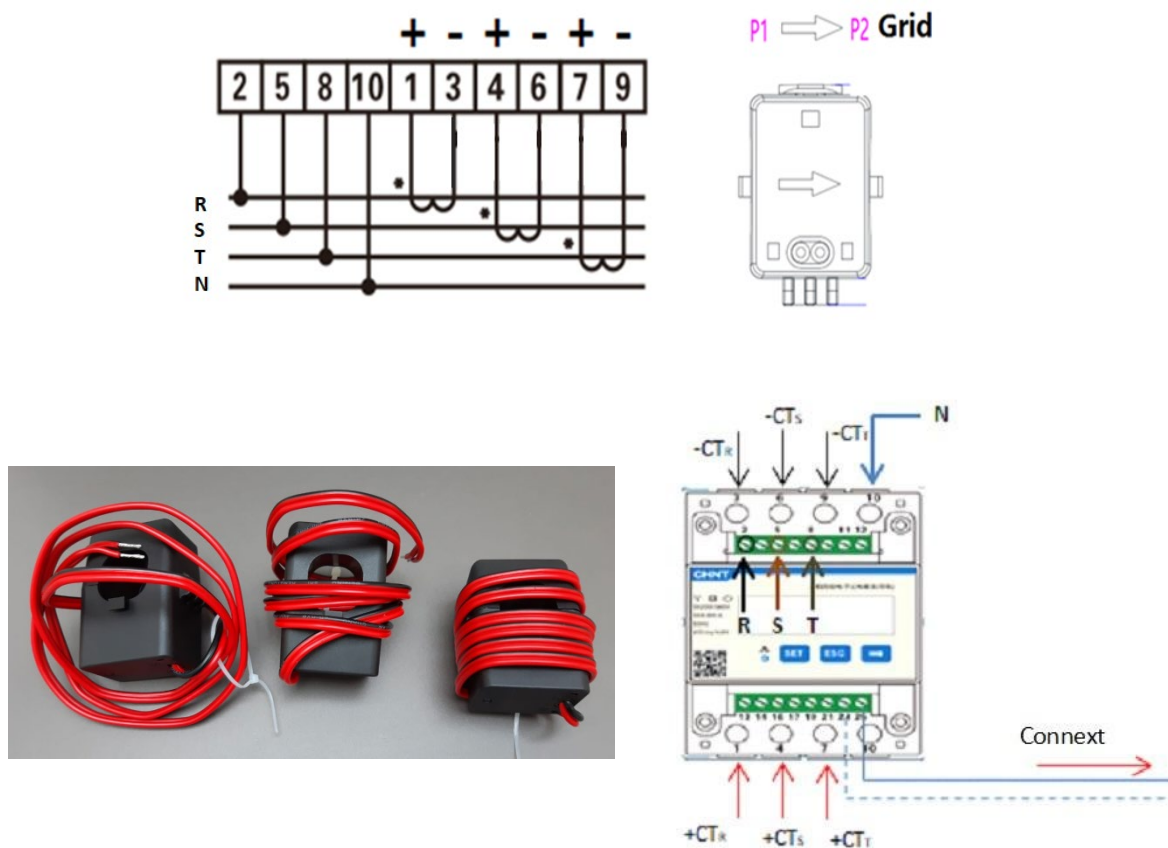

respectively.

Figure 75 - Meter connections



Press to:
 "Confirm"
 "Move the cursor
 (to enter digits)
 Press to "go back"
 Press to "add"

Figure 89 - Meter Legend

Meter configuration

To configure the device in reading mode, enter the settings menu as follows:

1. Press **SET** and the word **CODE** will appear

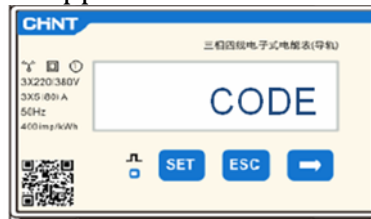

2. Press **SET** again, the number "600" will appear:



3. Enter the number "701":

- a. From the first screen where the number "600" appears, press the "→" key once to enter the number "601".
- b. Press SET twice to move the cursor to the left, highlighting 601.
- c. Press the "→" key once more to enter the number "701".

Note: If you make a mistake, press "ESC" and then "SET" again to reset the required code.



4. Confirm by pressing **SET** until you enter the settings menu.
5. Enter the following menus and set the parameters indicated:

a. **CT:**

- i. Press **SET** to enter the menu.
- ii. Enter '40':
 1. From the first screen where "1" appears, press the "→" key several times until the number "10" is displayed.
 2. Press "SET" once to move the cursor to the left, highlighting "10"
 3. Press the "→" key several times until the number "40" is displayed

Note: If you make a mistake, press "SET" until the thousands digit is highlighted, then press "→" until only the number "1" appears. then repeat the procedure described above.



- i. Press "ESC" to confirm and "→" to scroll to the next setting.

b. **ADDRESS:**

- i. Press **SET** to enter the menu:
- ii. Type "*" (by pressing "→" once from the "01" screen). (address 01 for exchange meter, 02/03/04 for external production meter)
- iii. Press "ESC" to confirm.



5. First start-up and configuration of Azzurro HUB

Azzurro HUB allows for simple commissioning via mobile device by simply using a web server accessible locally via an access point. The steps below allow you to configure the device after all connections with ZCS inverters, ZCS evchargers, ZCS meters, ZCS heat pumps, and LAN network (if used) have been correctly made.



Note

The images below may differ slightly from the actual ones due to possible software updates.

5.1. Step 1 - Connection to Access Point

Follow the steps described to connect:

- 1) Identify the QR code on the side of the Azzurro HUB and scan it using your mobile device.
- 2) Your mobile device will ask for authorisation to connect to the network created by Azzurro HUB. Grant authorisation and click on the 'Go to Azzurro HUB' button
- 3) Your mobile device will open the home page at the IP address 192.168.20.1:55560

5.2. Step 2 – Guided configuration via wizard

Azzurro HUB is equipped with a guided configuration wizard, which can be accessed by clicking on the 'Configuration Wizard' button on the home screen

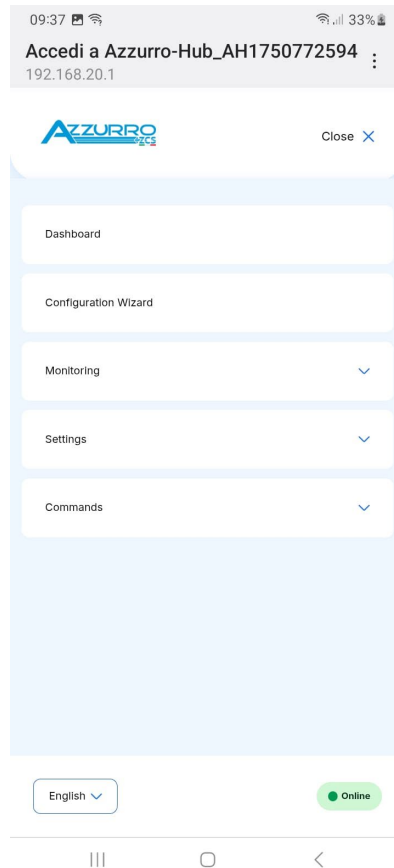

Figure 12 - Home screen

The wizard consists of 8 sequential steps that allow for complete configuration

5.2.1. Step 3 - Internal clock and connectivity

Select the correct time zone for managing the internal clock and choose the Wi-Fi or Ethernet cable connection

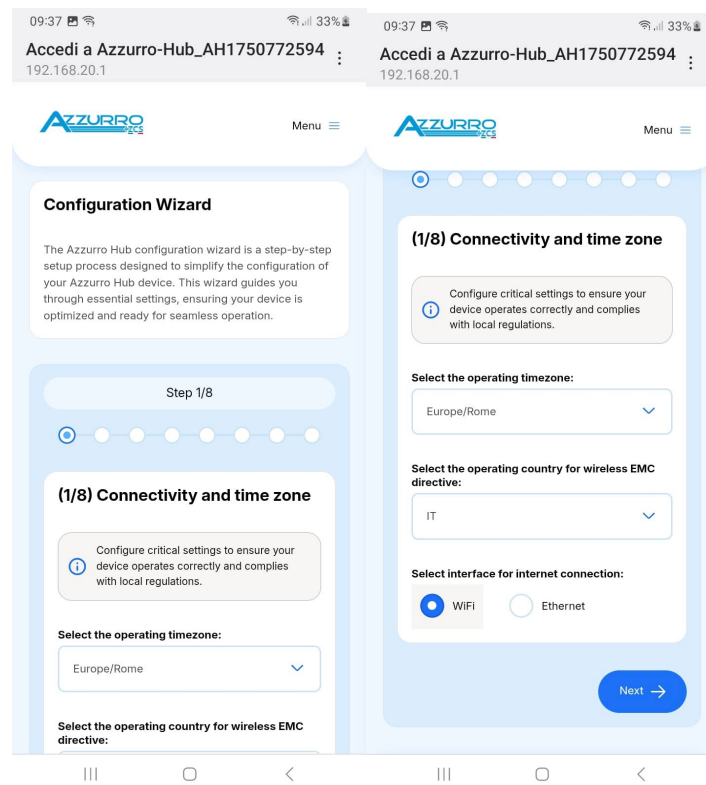

Figure 12 - Time zone and connectivity

5.2.2. Step 4 - Wi-Fi network connection

Scan the Wi-Fi networks accessible by Azzurro HUB and choose the network to connect to by entering the correct network password.

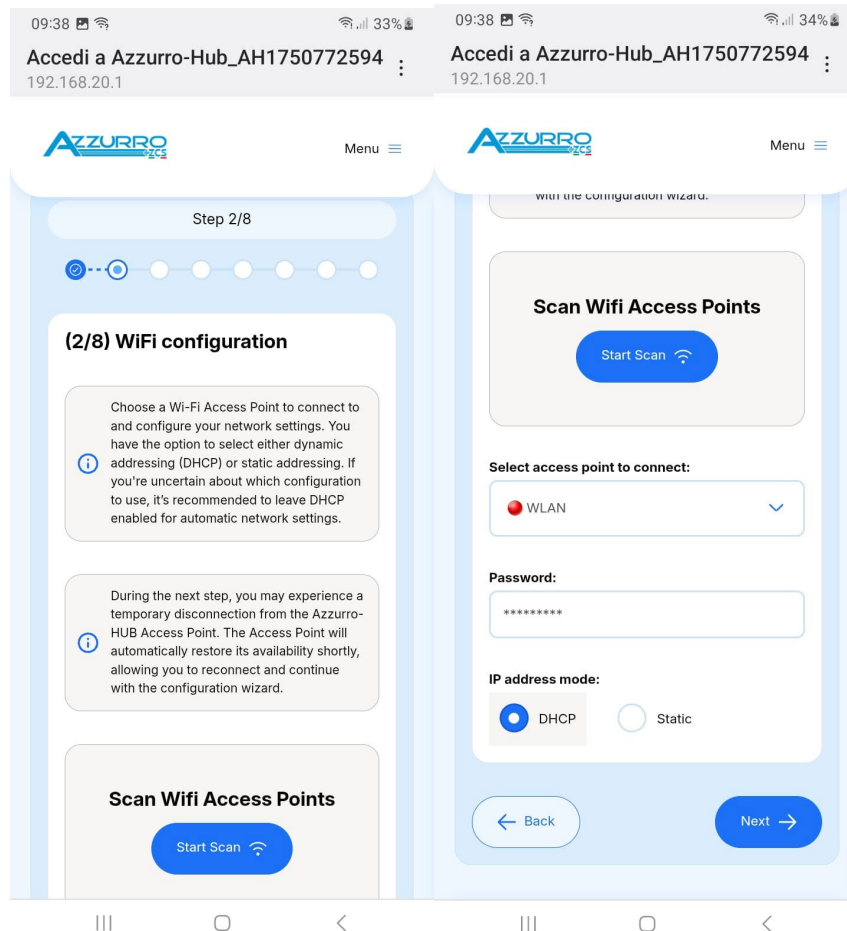

Figure 12 - Wi-Fi

The HUB device can also be set to work with a static IP by selecting it in the configuration.

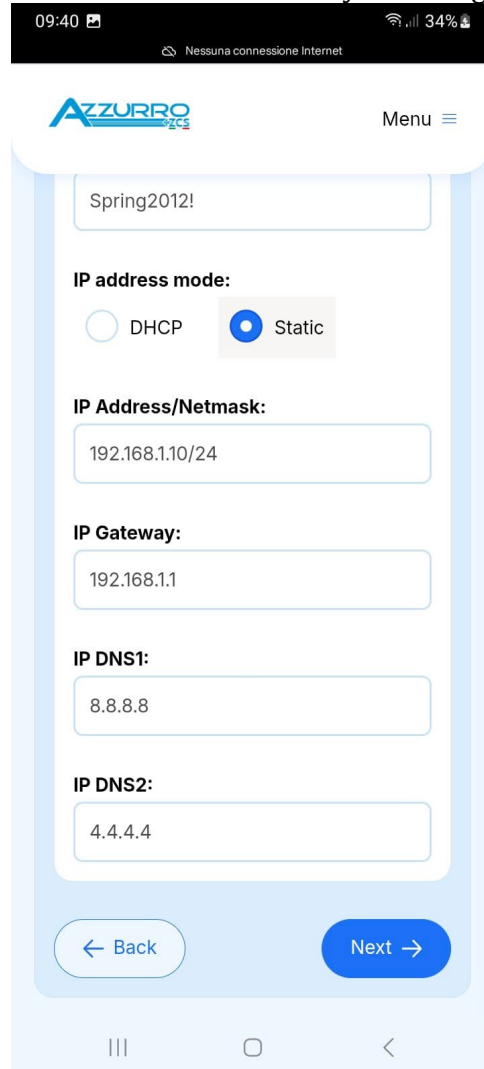

Figure 12 - Static IP definition

5.2.3. Step 5 - Connectivity test

Once the Wi-Fi has been set up correctly, or if the Ethernet cable has already been connected to the router or local network switch, the system performs a connectivity test.

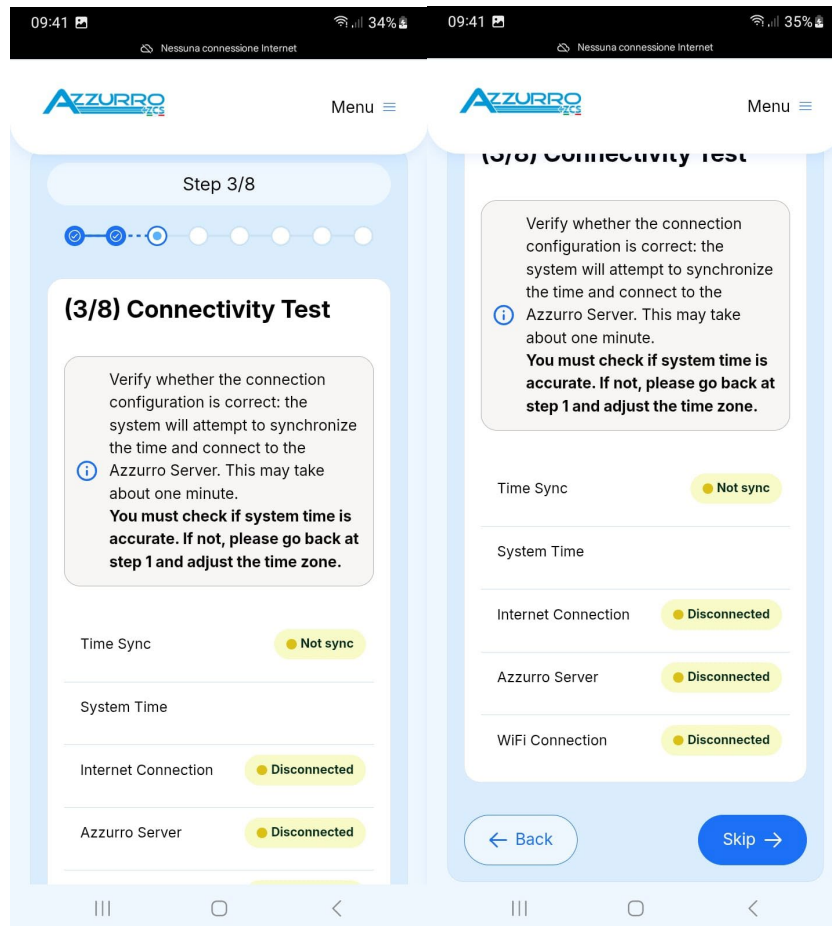

Figure 12 - Connectivity test result

If one of the connectivity tests fails, it will not be possible to view the data correctly on monitoring systems such as apps and portals.

If the result is 'disconnected', check that the Wi-Fi passwords are set correctly and that port 80 on the router is open.

5.2.4. Step 6 - System

This step of the configuration requires data relating to the electrical system to which the devices are connected.

These steps must be performed carefully to provide Azzurro HUB with the correct information.

First, HUB asks whether the system is single-phase or three-phase, referring to the electrical system connected to the network operator; enter single-phase if the exchange meter is single-phase or three-phase if the exchange meter is three-phase.

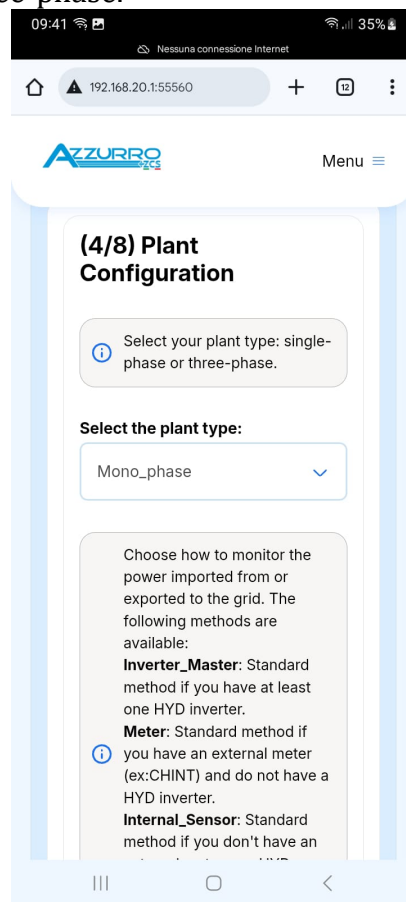

Figure 12 - type of connection system

HUB also asks which device performs the measurements at the exchange, offering four possibilities:

- **MASTER hybrid inverter** - use this selection if one or more hybrid inverters are present; in this case, the master performs the measurements at the exchange and HUB derives these measurements by requesting them from the master
- **Meter** - use this function when there are no hybrid inverters and the exchange reading is taken by a meter directly connected to Azzurro HUB

- **Internal sensor** - use this function if the exchange reading is taken by a current sensor directly connected to Azzurro HUB
- **Power Magic** - use this function if Azzurro HUB is connected to a Power Magic.

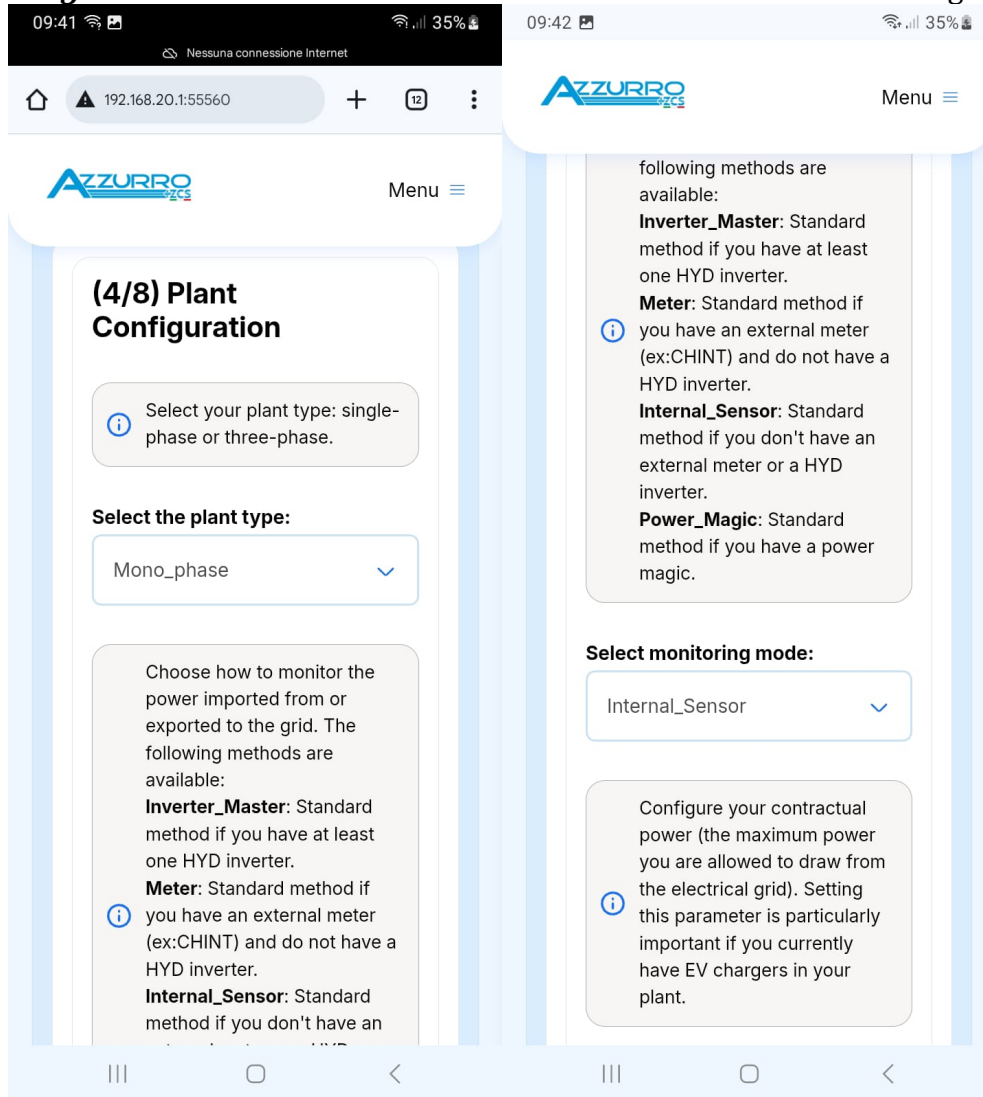



Figure 12 - exchange measurement mode

HUB also asks for the contractual power, meaning the power contracted with the grid operator for withdrawal.

	<p>DO NOT enter the power of the photovoltaic system at this point, but the power contracted with the grid operator for consumption</p>
<p>Note</p>	

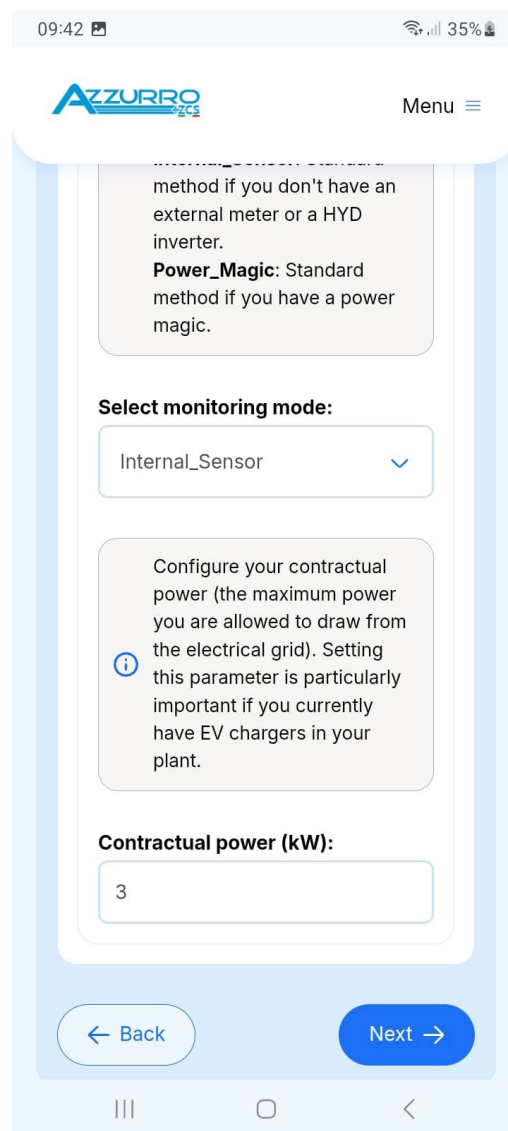

Figure 12 - Contractual power

5.2.5. Step 7 - Connected devices

By clicking on start scan, the system will automatically detect the inverters, meters or EV chargers correctly connected to the RS485 serial ports.

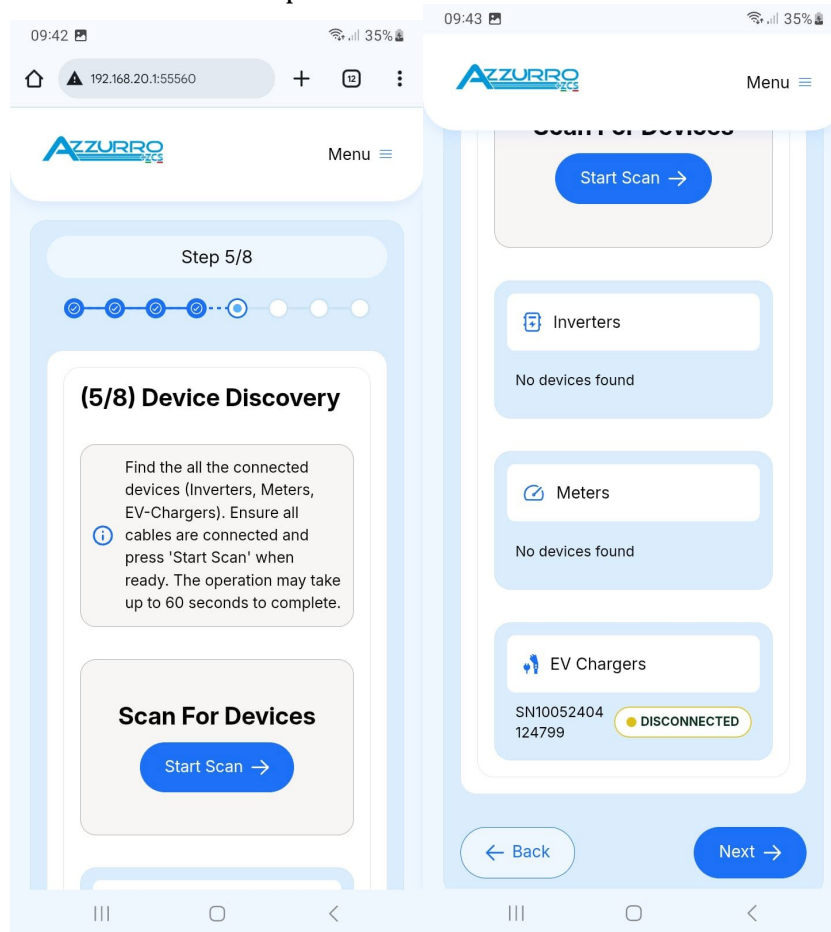

Figure 12 - serial scan

5.2.6. Step 8 - 0 input function

In this section, you can enable the input 0 function for the system and set the desired target power.

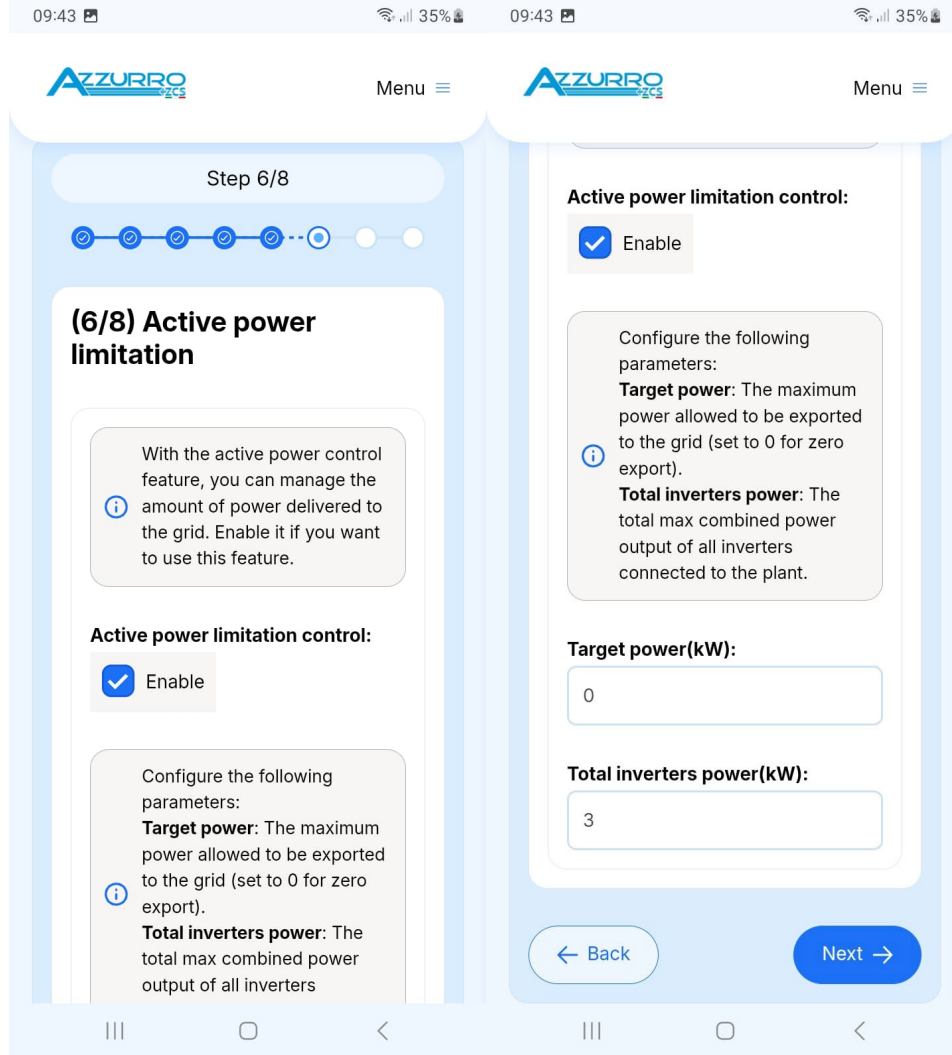

Figure 12 - Input 0 function

5.2.7. Step 9 - Inverter connection standard selection

Click on the section "Select country/region for inverter safety standards:" and select the correct connection standard.

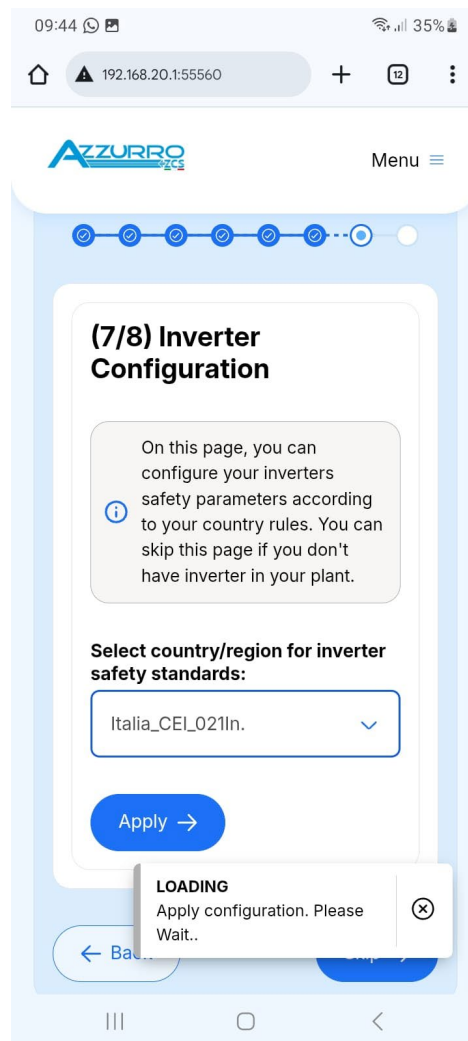

Figure 12 - Country selection

5.2.8. Step 10 - End of procedure

Once the configuration procedure is complete, you can access the Azzurro HUB dashboard to make modifications, changes or simply checks.

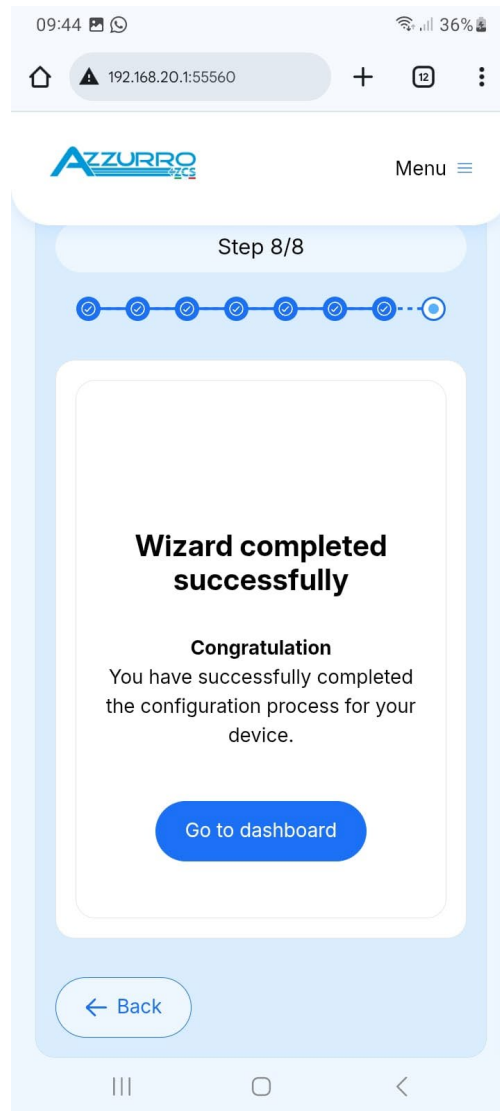

Figure 12 - End of procedure

6. Uninstallation

6.1. Uninstallation steps

- Disconnect the system/device from the power supply.
- Disconnect the device from the AC mains.
- To remove the signal cables from the device:
- Remove the DIN rail and remove the device.

6.2. packaging

If possible, pack the device in its original packaging.

6.3. Storage

Store the device in a dry place at an ambient temperature between -25 and +60°C.

6.4. Disposal

Zucchetti Centro Sistemi S.p.A. is not responsible for the disposal of equipment or parts thereof that do not comply with the regulations and standards in force in the country of installation.



The crossed-out wheeled bin symbol indicates that the equipment, at the end of its useful life, must be disposed of separately from household waste.

This product must be taken to the local community waste collection point for recycling.

For further information, contact your local waste collection authority.

Improper disposal of waste could adversely affect the environment and human health due to potentially hazardous substances.

By cooperating in the proper disposal of this product, you are contributing to the reuse, recycling and recovery of the product and the protection of the environment.

7. warranty terms and conditions

To consult the warranty terms and conditions offered by Zcs Azzurro, please refer to the documentation inside the product box and on the website www.zcsazzurro.com.



zcsazzurro.com



Zucchetti Centro Sistemi S.p.A.
Green Innovation Division
Palazzo dell'Innovazione - Via Lungarno, 167
52028 Terranuova Bracciolini - Arezzo, Italy
zcscompany.com

