



USER'S MANUAL



SINGLE-PHASE STRING INVERTERS

1PH 1100TL-5000TL-V3



ZUCCHETTI
Centro Sistemi



IMPORTANT MESSAGE

Dear Customer,

inside the box of this product you can find the manuals in English.

Please note that revised and/or updated versions of the aforementioned documentation may be available, therefore in order to guarantee the correct installation procedure it is necessary to check the documentation available on the website www.zcsazzurro.com in the documentation or products section or directly by scanning the QrCode placed on the front of the product.

Thank you

Team Azzurro Zcs

Zucchetti Centro Sistemi S.p.A. - Green Innovation Division
Palazzo dell'Innovazione - Via Lungarno, 167
52028 Terranuova Bracciolini - Arezzo, Italy
Partita IVA 01262190513 – C.F. 03225010481 Codice Univoco SDI SUBM70N
tel. +39 055 91971 - fax. +39 055 9197515

innovation@zcscompany.com - zcs@pec.it - zcsazzurro.com

Reg. Pile IT12110P00002965 - Capitale Sociale € 100.000,00 I.V.

Reg. Impr. AR n.03225010481 - REA AR - 94189

Azienda Certificata

ISO 9001 - Certificato n. 9151 - CNSQ - IT-17776

ISO14001 - Certificato n.1425 - CNSQ - IT-134812

EPD Italy - Certificati al link epditaly.it



Grid-connected inverter

1PH 1100TL2-V3/1PH 5000TL2-V3

User Manual



Table of Contents

1.	Preliminary safety instructions	10
1.1.	Target group	10
1.2.	Qualified personnel	11
1.3.	Installation requirements	11
1.4.	Transport requirements	12
1.5.	Electrical connections	12
1.6.	Operation	13
1.7.	Maintenance and repair	13
1.8.	EMC / noise level of inverter	14
1.9.	Symbols and signs	15
2.	Product features	18
2.1.	Product presentation	18
2.2.	Product dimensions	19
2.3.	Labels on the inverter	20
2.4.	Description of functions	20
2.5.	Electrical block diagram	22
2.6.	Efficiency curve	22
3.	Inverter Storage	24
4.	Installation	25
4.1.	Installation process	26
4.2.	Checks before installation	26
4.3.	Unpacking the inverter	27
4.4.	Checking the delivery scope	28
4.5.	Installation tools	30
4.6.	Installation position	32
4.7.	Installing the 1PH 1100TL2-V3/1PH 5000TL2-V3 inverter	34



5.	Electrical connections.....	36
5.1.	Connection sequence.....	38
5.2.	Terminal connector.....	39
5.3.	Ground cable connections (PGND).....	40
5.4.	Connecting the DC input power cables.....	42
5.5.	Connecting the AC output power cables.....	46
5.6.	Connecting the communication cables.....	51
6.	Commissioning the inverter.....	58
6.1.	Safety inspection before commissioning.....	58
6.2.	Starting the inverter.....	58
7.	Operating interface.....	60
7.1.	Operating panel and display.....	60
7.2.	Main interface.....	61
7.3.	Main menu.....	63
8.	Troubleshooting and maintenance.....	82
8.1.	Troubleshooting.....	82
8.2.	Maintenance.....	89
9.	Uninstalling.....	90
9.1.	Uninstallation steps.....	90
9.2.	Packaging.....	90
9.3.	Storage.....	90
9.4.	Disposal.....	90
10.	Technical specifications.....	91
11.	Monitoring systems.....	92
11.1.	External Wi-Fi adapter.....	93
11.1.1.	Installation.....	93
11.1.2.	Configuration.....	94
11.1.3.	Verification.....	103
11.1.4.	Troubleshooting.....	107
11.2.	Ethernet adapter.....	111
11.2.1.	Installation.....	111



11.2.2.	Verification	113
11.2.3.	Troubleshooting.....	114
11.3.	4G adapter	116
11.3.1.	Installation.....	116
11.3.2.	Verification	118
11.3.3.	Local monitoring.....	121
11.3.3.1.	Requirements for installation of local monitoring	121
11.3.3.2.	Features of local monitoring	121
12.	Warranty terms and conditions.....	123



General instructions

This manual contains important safety instructions that must be followed during installation and maintenance of the equipment.

Please keep these instructions!

This manual must be considered an integral part of the equipment, and must be available at all times to everyone who interacts with the equipment. The manual must always accompany the equipment, even when it is transferred to another user or plant.

Copyright statement

Copyright of this manual belongs to Zucchetti Centro Sistemi S.p.A. No part of this manual (including the software, etc.) may be copied, reproduced or distributed in any form or by any means without the permission of Zucchetti Centro Sistemi S.p.A. All rights reserved. ZCS reserves the right to final interpretation. This manual is subject to change based on feedback from users, installers or customers. Please check our website at <http://www.zcsazzurro.com> for the latest version.

Technical support

ZCS offers a support and technical consultancy service accessible by sending a request directly from the website www.zcsazzurro.com

The following toll-free number is available for the Italian territory: 800 72 74 64.

Preface

General information

This Installation and user manual (hereinafter referred to as the manual) describes the installation, electrical connection, commissioning, maintenance and fault elimination procedures of the following products:

ZCS 1.1KTL3-V3, ZCS 1.6KTL3-V3, ZCS 2.2KTL3-V3, ZCS 2.7KTL3-V3, ZCS 3KTL3-V3, ZCS 3.3KTL3-V3, ZCS 4KTL3-V3, ZCS 5KTL3-V3.

- ✓ Carefully read this manual before use and retain it for future reference!
- ✓ Treat this manual as an integral component of the device.
- ✓ Please retain this manual in a readily accessible location for future reference.

This manual contains important safety information on the installation, operation and maintenance of the device.

- ✓ Read and observe all given safety information.

The products, services or features you purchased shall be subject to the company's commercial contracts and terms. All or part of the products and services described in this document may not within the scope of your purchase. Unless additional terms and conditions in your contract, the company does not make any statement or guarantee on the contents of this document.

- **Copyright declaration**

The copyright of this manual is owned by Zucchetti Centro Sistemi Spa. It may not be copied – neither partially nor completely – by companies or individuals (including software, etc.) and must not be reproduced or distributed in any form, or with the appropriate means.

Zucchetti Centro Sistemi Spa reserves the right to final interpretation. This manual may be amended following feedback from users or customers.


Please consult our website at www.zcsazzurro.com for the latest version.

- **Presentation of warnings**






This manual contains information on safe operation and uses symbols to ensure the safety of persons and property as well as the efficient operation of the inverter.

- ✓ Read through the following symbol explanations carefully in order to prevent injury or property damage.

- **Warning symbol**

	<p>The general danger symbol warns of risk of serious injury when used with the signal words CAUTION, WARNING, and DANGER.</p>
---	--

- **Signal word**

 <div style="background-color: red; color: white; padding: 2px; text-align: center;">Danger</div>	<p>Danger: indicates a hazardous situation which, if not resolved or avoided, could result in serious personal injury or death.</p>
 <div style="background-color: orange; color: white; padding: 2px; text-align: center;">Warning</div>	<p>Warning: indicates a hazardous situation which, if not resolved or avoided, could result in serious personal injury or death.</p>
 <div style="background-color: yellow; color: black; padding: 2px; text-align: center;">Caution</div>	<p>Caution: indicates a hazardous situation which, if not resolved or avoided, could result in minor or moderate personal injury.</p>
 <div style="background-color: blue; color: white; padding: 2px; text-align: center;">Attention</div>	<p>Attention: indicates a potentially hazardous situation which, if not resolved or avoided, could result in damage to the system or other property.</p>
 <div style="background-color: gray; color: white; padding: 2px; text-align: center;">Note</div>	<p>Note: provides important tips on the correct and optimal operation of the product.</p>



- **Sectional warnings**

Sectional warnings refer to a complete section and are structured as follows:

▲ WARNING
<p>Type and source of danger Consequences for non observance ▶ Avoiding the danger</p>

- **Embedded warnings**

Embedded warnings are part of an action sequence and are placed right before the dangerous step.


WARNING Combination of type/source of danger, consequences for non-observance and avoiding the danger.

- **Presentation of action instructions**

This table shows the sequence of Action steps:

Symbol	Function
✓	This describes an action requirement
1. 2. 3.	This is the sequence of action steps that must be followed step by step
▶	This is a single-action step
↳	This describes the result of the action

- **Note**


	<p>Provides important tips on the correct and optimal operation of the product.</p>
<p>Note</p>	



1. Preliminary safety instructions



This chapter details the safety information pertaining to the installation and operation of the device.

 Note	<p>If you have problems or questions regarding the reading and understanding of the following information, please contact Zucchetti Centro Sistemi S.p.A. through the appropriate channels.</p>
--	--

Read and understand the instructions within this manual and familiarise yourself with the relevant safety symbols in this chapter before beginning with the installation of the device and eliminating any faults.

Before connecting to the power grid, you must obtain official authorisation from the local power grid operator in accordance with the corresponding national and state requirements. Furthermore, operation may only be carried out by qualified electricians.

Please contact the nearest authorised service centre if any maintenance or repairs are required.

- ✓ Please contact your dealer to obtain information about your nearest authorised service centre.
- ✓ Do NOT carry out repairs on the device yourself, this may lead to injury or property damage.
- ✓ Before installing the device or carrying out maintenance on it, you must turn off the DC switch in order to interrupt the DC voltage of the PV generator. You can also switch off the DC voltage by turning off the DC switch in the array junction box. Not doing this may result in serious injury.

1.1. Target group

This manual is intended for qualified electricians who are responsible for the installation and commissioning of the inverter in the PV system, as well as the PV system operators.



1.2. Qualified personnel

Personnel tasked with the operation and maintenance of the device must have the qualifications, competence and experience required to perform the described tasks, while also being capable of fully understanding all instructions contained within the manual. For safety reasons, this inverter may only be installed by a qualified electrician.

Requirements for qualified electricians:

- ✓ Personnel have received training on occupational safety, as well as the installation and commissioning of electrical systems.
- ✓ Personnel are familiar with the local laws, standards and regulations of the grid operator.

Zucchetti Centro Sistemi S.p.A. declines all responsibility for damage to property or personal injury caused by incorrect use of the device.

1.3. Installation requirements

Install the inverter according to the information contained in the following section.

- ✓ Choose a suitable place for the installation of electrical devices.
- ✓ Ensure that there is sufficient space for an emergency exit which is suitable for maintenance.
- ✓ Installation of the inverter must conform with laws, regulations, codes and standards applicable in the jurisdiction.
- ✓ Before connecting the product to the electrical utility grid, contact the local utility company for approval.

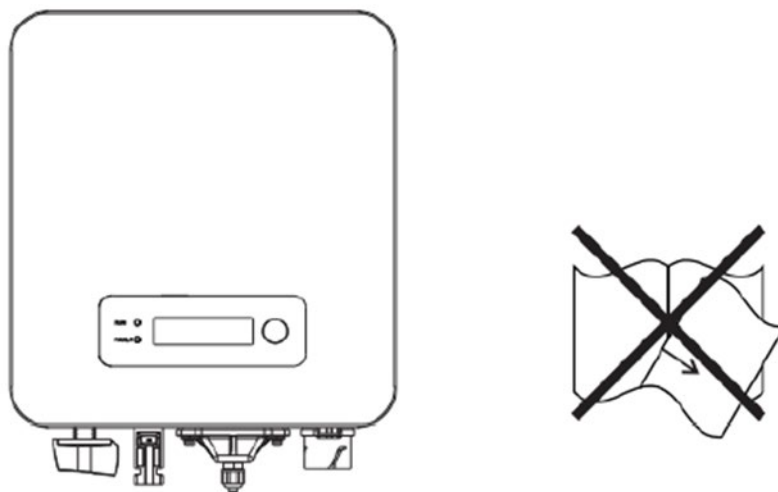


Figure 1 - Do not lose or damage this manual

1.4. Transport requirements





The factory packaging is specifically designed to prevent transport damage, i.e. violent shocks, moisture and vibrations. However, the device must not be installed if it is visibly damaged. In this case, notify the responsible transport company immediately. If necessary, you can seek help from your photovoltaic system installer or Zucchetti Centro Sistemi SpA.

The stacking height of multiple inverters should not exceed the stacking limit indicated on the outer box.



If the inverter is stored for more than half a year, the inverter needs to be fully examined and tested by qualified service or technical personnel before use. For storage conditions see Technical Data.

1.5. Electrical connections



Observe all applicable electrical regulations when working with the Solar inverter.

	<p>Dangerous DC voltage</p> <ul style="list-style-type: none"> • Before establishing the electrical connection, cover the PV modules using opaque material or disconnect the PV generator from the inverter. Solar radiation will cause dangerous voltage to be generated by the PV generator!
<p>Danger</p>	
	<p>Danger through electric shock!</p> <ul style="list-style-type: none"> • All installations and electrical connections may only be carried out by trained electricians!
<p>Danger</p>	
	<p>Authorisation for grid feed-in</p> <ul style="list-style-type: none"> • Obtain authorisation from the local power grid operator before connecting the inverter to the public power grid.
<p>Attention</p>	
	<p>Do not remove the information label or open the inverter.</p> <p>Otherwise, ZCS will not provide any warranty or maintenance.</p>
<p>Note</p>	

1.6. Operation

	<p>Electric shock</p> <ul style="list-style-type: none"> • Contact with the electrical grid or the device's terminals may result in an electric shock or fire! • Do not touch the terminal or the conductor which is connected to the electrical grid. • Follow all instructions and observe all safety documents that refer to the grid connection.
<p>Danger</p>	
	<p>Burning due to hot housing</p> <ul style="list-style-type: none"> • While the inverter is being operated, several internal components will become very hot. Please wear protective gloves! • Keep children away from the device!
<p>Caution</p>	


1.7. Maintenance and repair

	<p>Dangerous voltage!</p> <ul style="list-style-type: none"> • Before carrying out any repair work, first switch off the AC circuit breaker between the inverter and power grid, and then the DC switch. • After switching off the AC circuit breaker and the DC switch, wait a minimum of 5 minutes before starting any maintenance or repair work.
<p>Danger</p>	
	<p>Unauthorised repairs!</p> <ul style="list-style-type: none"> • Following the elimination of any faults, the inverter should be fully functional once more. Should any repairs be required, please contact a local authorised service centre. • The internal components of the inverter must NOT be opened without the relevant authorisation. Zucchetti Centro Sistemi Spa assumes no responsibility for any resulting losses or defects.
<p>Attention</p>	





1.8. EMC / noise level of inverter

Electromagnetic compatibility (EMC) refers to the fact that electrical equipment functions in a given electromagnetic environment without any trouble or error, and imposes no unacceptable effect upon the environment. Therefore, EMC represents the quality characteristics of an electrical equipment.

- ✓ The inherent noise-immune character: immunity to internal electrical noise.
- ✓ External noise immunity: immunity to electromagnetic noise of the external system.
- ✓ Noise emission level: influence of electromagnetic emission upon environment.









	<p>Electromagnetic radiation from the inverter may be harmful to health!</p> <ul style="list-style-type: none">• Please do not continue to stay around the inverter for less than 20 cm when the inverter is working.
Danger	

1.9. Symbols and signs



	<p>Dangerous DC voltage</p> <ul style="list-style-type: none"> • High voltage circuits of inverters can endanger life. • All installations and electrical connections may only be carried out by trained electricians. • Minors, individuals with disabilities, and those with mental health conditions are prohibited from using this product. • This product should be installed out of the reach of children.
<p style="background-color: red; color: white; text-align: center; padding: 5px;">Danger</p>	
	<p>Beware of burning hazards due to the hot housing!</p> <ul style="list-style-type: none"> • While the inverter is in operation, only touch the display and the buttons, as the housing can become hot.
<p style="background-color: orange; color: white; text-align: center; padding: 5px;">Caution</p>	
	<p>Implement earthing!</p> <ul style="list-style-type: none"> • The PV generator must be earthed in accordance with the requirements of the local power grid operator! • For reasons of personal safety, we recommend that all PV module frames and inverters of the PV system are reliably earthed.
<p style="background-color: blue; color: white; text-align: center; padding: 5px;">Attention</p>	
	<p>Damage due to overvoltage</p> <ul style="list-style-type: none"> • Ensure that the input voltage does not exceed the maximum permissible voltage. Overvoltage may cause long-term damage to the inverter, as well as other damage that is not covered by the warranty.
<p style="background-color: orange; color: white; text-align: center; padding: 5px;">Warning</p>	

Symbols on the inverter

Several symbols pertaining to safety can be found on the inverter. Please read and understand the content of these symbols before starting the installation.

	<p>Residual voltage may be present on the inverter! Before opening the inverter, wait 5 minutes to ensure that the capacitors are completely discharged.</p>
	<p>Caution! Danger through electric shock</p>
	<p>Caution! Hot surface</p>
	<p>Complies with the European Standards (CE)</p>
	<p>Ground connection point</p>
	<p>Read this manual before installing the inverter.</p>
	<p>Indication of the allowable temperature range</p>
	<p>Degree of protection of the equipment according to the IEC 70-1 standard (EN 60529 June 1997).</p>
	<p>Positive and negative polarities of the input voltage (DC).</p>



	<p>RCM (Regulatory Compliance Mark)</p> <p>The product meets the requirements of the applicable Australian standards.</p>
	<p>When the equipment is scrapped, it is disposed of following local laws and regulations or sent to the manufacturer.</p>



2. Product features

General information in this chapter

Product dimensions

The field of use and overall dimensions of the 1PH 1100TL2-V3/1PH 5000TL2-V3 inverters are indicated in this section.

Description of functions

Describes how the 1PH 1100TL2-V3/1PH 5000TL2-V3 inverters and their internal operating modules work.

Efficiency curve

Describes the efficiency curves of the inverter.

2.1. Product presentation

Field of use

The 1PH 1100TL2-V3/1PH 5000TL2-V3 is a single MPPT grid-tied PV inverter which converts the DC power generated by PV arrays into sine wave single-phase AC power and feeds it to the public electrical grid, AC circuit breaker and DC switch used as disconnect device, and the disconnect device shall be easily accessible.

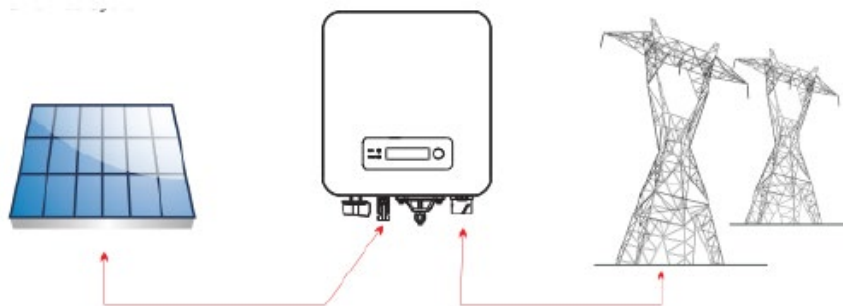


Figure 2 – Grid-connected photovoltaic system

The 1PH 1100TL2-V3/1PH 5000TL2-V3 inverters can only be used with photovoltaic modules that do not require one of the poles to be grounded. The operating current during normal operation must not exceed the limits specified in the technical specifications. Only the photovoltaic modules can be connected to the input of the inverter (do not connect batteries or other sources of power supply).

The choice of optional parts of inverter should be made by a qualified technician who knows the installation conditions clearly.



- Accessories and optional components of the inverter should be chosen by a qualified technician who is familiar with the installation conditions.

2.2. Product dimensions

- ✓ Overall dimensions 1PH 1.1-3.3KTL-V3 : $W \times H \times D = 260.5 \times 321 \times 131.5 \text{ mm}$
- ✓ Overall dimensions 1PH 4-5KTL-V3 : $W \times H \times D = 260.5 \times 321 \times 151.5 \text{ mm}$

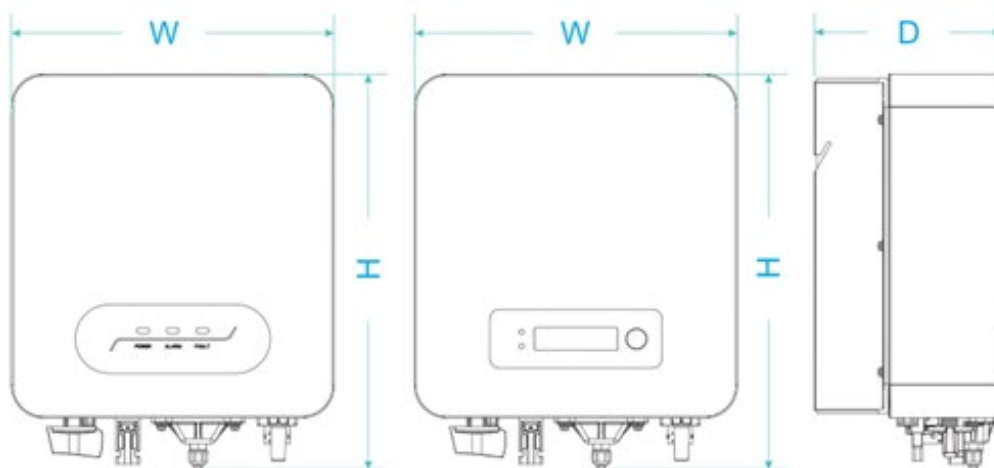



Figure 3 – Front, side and back view of the inverter and bracket

	<p>This product is available with or without the LCD display. Please install and configure them based on the specific condition of the inverters you received.</p>
Note	

Bracket dimensions of inverter:

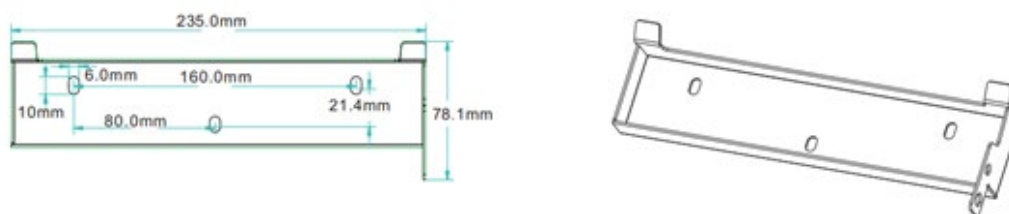
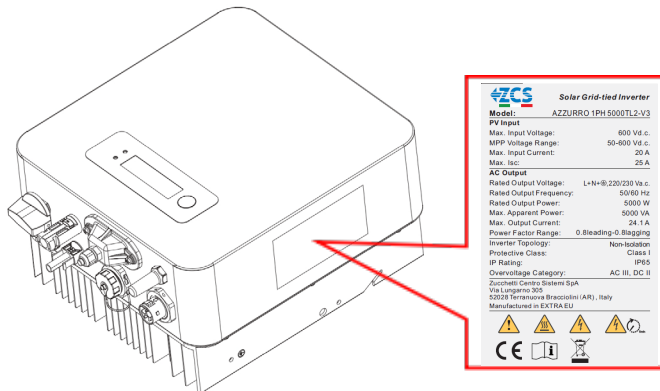



Figure 4 – Bracket

2.3. Labels on the inverter



Le etichette non devono essere nascoste con oggetti o corpi estranei (stracci, scatole, attrezzature, ecc.) e devono essere pulite regolarmente e mantenute sempre visibili

Figure 5 - Do not remove the label on the side of the inverter

	<p>The machine nameplate must not be obscured or broken by other objects (rags, cardboard boxes or other tools); the surface of the machine nameplate must be kept clean and clear to ensure that the contents are clearly visible</p>
<p>Note</p>	

2.4. Description of functions

The DC output generated by the PV generator is filtered by the input board before it reaches the power board. The input board also provides functions such as the detection of insulation impedance and the measurement of the DC current and voltage. The power board converts the DC current into AC current. The AC current is filtered by the output board and fed into the power grid. The output board also provides functions such as grid voltage and current measurement, earth fault protection and a disconnecting relay. The control board supplies the auxiliary energy, controls the operating state of the inverter and displays the operating status on the display board. An error code will appear on the display if the inverter is in an abnormal operating state. At the same time, the control board may trigger the relay to protect the internal components.

Inverter functions

A. Feeding reactive power into the grid

This control can be used to switch the inverter on/off through an external (remote) control.

B. Limiting the active power fed into the grid

The inverter is able to produce reactive power and can therefore feed it into the grid through the setting of the phase shift factor. Feed-in management can be controlled directly by the grid company through a dedicated RS485 serial interface.

C. Limiting the active power fed into the grid

The inverter, if enabled can limit the amount of active power fed into the grid by the inverter to the desired value (Expressed as a percentage).

D. Self-power reduction when the grid is over frequency

When the grid frequency is higher than the limited value, the inverter will reduce output power, which is necessary for grid stability.

E. Data transmission

The inverter or a group of inverters may be monitored remotely through an advanced communication system based on RS-485 serial interface, or remotely via the WIFI/GPRS.

F. Software update

Support USB flash drive local upgrade software and Wi-Fi/GPRS remote upgrade software.

2.5. Electrical block diagram

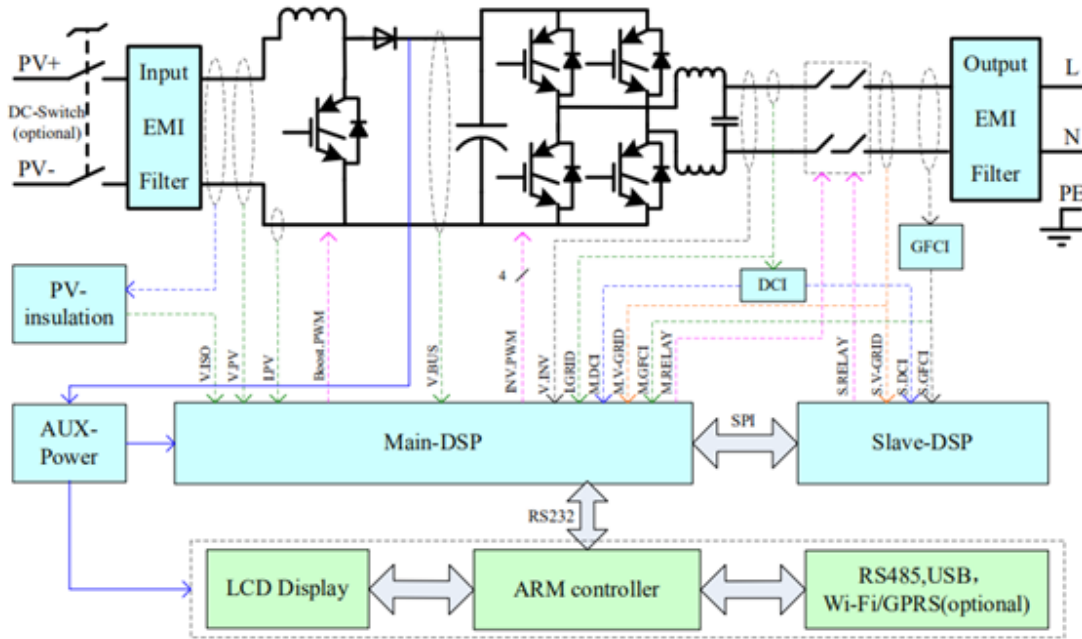


Figure 6 - Block diagram of the 1PH 1100TL2-V3/1PH 5000TL2-V3-L inverter

2.6. Efficiency curve

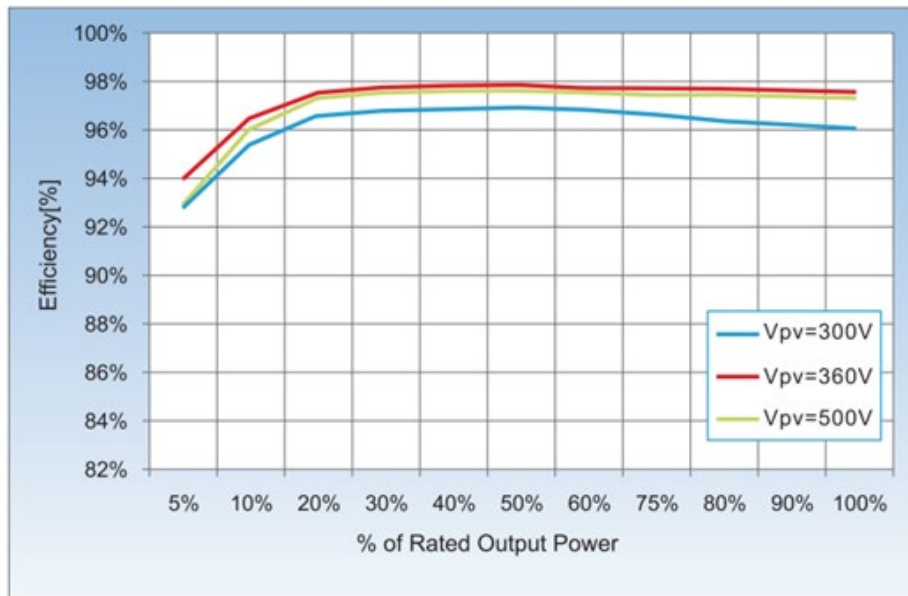


Figure 7 - Efficiency curve for an Azzurro ZCS 1PH 1100TL2-V3/1PH 5000TL2-V3 inverter





3. Inverter Storage

If the inverter is not installed immediately, storage conditions need to meet the below requirements:

Place the inverter in the original packing case with the desiccant inside.

Keep the storage temperature around -30°C to $+70^{\circ}\text{C}$, Relative humidity 5 to 95%, non-condensing.

In case of stacking storage, the number of stacking layers should never exceed the limit marked on the outer side of the packing case.

The packing case should be upright.

If the inverter needs to be transported again, pack it strictly before loading and transporting it.

Do not store the inverter in places susceptible to direct sunlight, rain, and strong electric field.

The inverter needs to be stored in a clean and dry place and protected from dust and moisture.

Inverters stored for half a year and above need to be inspected and tested by a professional before being put into use.



Please store the product in accordance with the storage requirements. Damage to the product caused by storage conditions that do not meet the requirements will not be covered by the warranty.




Note

4. Installation

General information in this chapter

This chapter describes how to install the 1PH 1100TL2-V3/1PH 5000TL2-V3 inverter.

Installation notes:

	<p>Fire hazard</p> <ul style="list-style-type: none"> • Do NOT install the inverter on flammable material. • Do NOT install the inverter in an area in which flammable or explosive material is stored.
<p>Danger</p>	
	<p>Burning hazard</p> <ul style="list-style-type: none"> • Do NOT install the inverter in places where it can be accidentally touched. The housing and heat sink may become very hot while the inverter is being operated.
<p>Caution</p>	
	<p>Handling Safety</p> <ul style="list-style-type: none"> • Consider the weight of the inverter when transporting and moving it. • Choose a suitable installation location and surface. • Commission a minimum of two persons for the installation of the inverter. • Do not turn the inverter upside down.
<p>Attention</p>	



4.1. Installation process

Mechanical installation is performed as follows:

1. Examine the inverter before installation
2. Prepare the installation
3. Select an installation location
4. Transport the inverter
5. Mount the rear panel
6. Install the inverter



Figure 8 - Installation steps

4.2. Checks before installation

Before unpacking the inverter, check the external packaging material for damage, e.g. holes and cracks. If you discover any cases of damage, do not unpack the inverter and contact the transport company and/or dealer immediately.

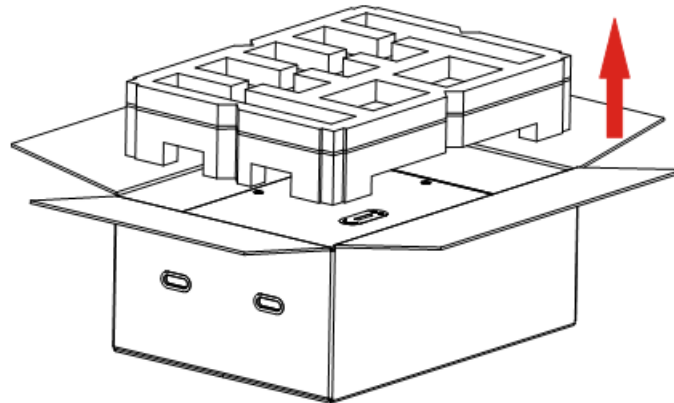
Do not install the inverter if the packaging is damaged.

It is recommended that the packaging material should be removed within 24 hours before installing the inverter.

Keep the original packaging and use it whenever the inverter needs to be shipped or transported.

4.3. Unpacking the inverter

Step 1: Open the packaging and have at least two people grip underneath the inverter at both sides.



Note

Do not put the inverter with wiring terminals contacting the floor because the power ports and signal ports are not designed to support the weight of the inverter.

- When placing the inverter on the floor, put it above foam or paper to avoid the damage of the shell of the inverter.

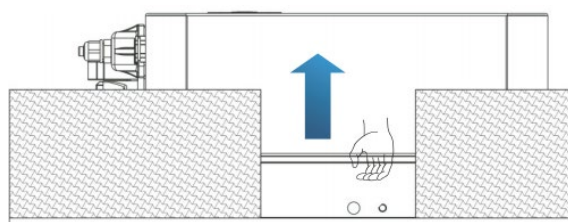
Step 2:



Caution

Do not put the inverter with wiring terminals contacting the floor because the power ports and signal ports are not designed to support the weight of the inverter.


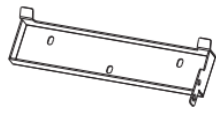
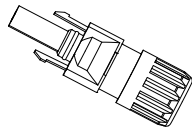
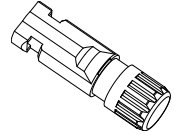
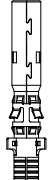

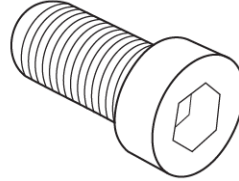


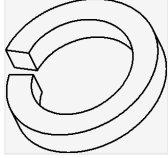
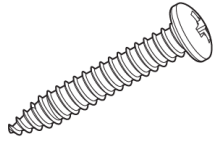
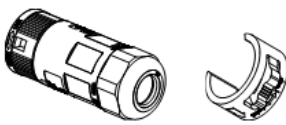
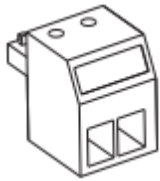



- When placing the inverter on the floor, put it above foam or paper to avoid the damage of the shell of the inverter.




4.4. Checking the delivery scope

Check that the delivery is intact and complete.

In the event of any damage or missing components, contact the wholesaler.

 <p>1 Photovoltaic inverter</p>	 <p>1 Rear panel</p>	 <p>1 + input terminal</p>	 <p>1 - input terminal</p>
 <p>1 metal terminal for + DC power cables</p>	 <p>1 metal terminal for - DC power cables</p>	 <p>2 M5 hexagonal screws</p>	 <p>5 M5 flat washers</p>
 <p>3 expansion bolts</p>	 <p>5 spring shim</p>	 <p>3 self-tapping screws</p>	 <p>1 AC output connector</p>
 <p>1 485 terminal (2 pin)</p>	 <p>1 user manual</p>	 <p>2 warranty</p>	 <p>1 Warranty Registration</p>

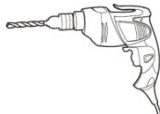
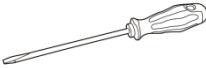

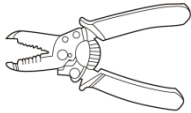






 <p>1 Outgoing inspection report</p>			
---	--	--	--

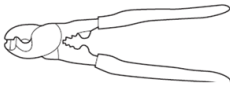
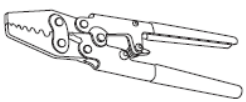
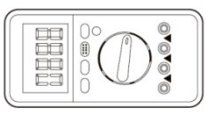

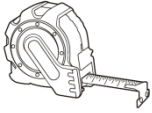
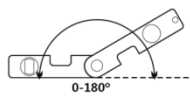
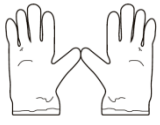




4.5. Installation tools

The following tools are required for installation of the inverter and electrical connections; therefore, they must be prepared before installation.


No.	Tool	Function
1	 Drill Recommended drill bit: 6mm	To drill holes in the wall for fixing the bracket
2	 Screwdriver	To screw and unscrew screws for the various connections
3	 Cross screwdriver	Remove and install AC terminal screws
4	 Wire stripper	To prepare the cables for wiring
5	 5 mm Allen key	To screw the inverter to the wall-mounting bracket and to open the front cover of the inverter
6	 Rubber hammer	To insert the expansion bolt
7	 MC4 removal tool	To remove the DC connectors from the inverter
8	 Diagonal pliers	To cut and tighten the cable ends



9		Cable cutter	To cut the power cables
10		Crimping tool	To crimp the power cables
11		Multi-meter	To check the voltage and current values
12		Marker pen	To mark the wall for better fixing precision
13		Measuring tape	To measure distances
14		Level	To make sure the bracket is level
15		ESD gloves	Protective clothing
16		Safety goggles	Protective clothing
17		Protection mask	Protective clothing

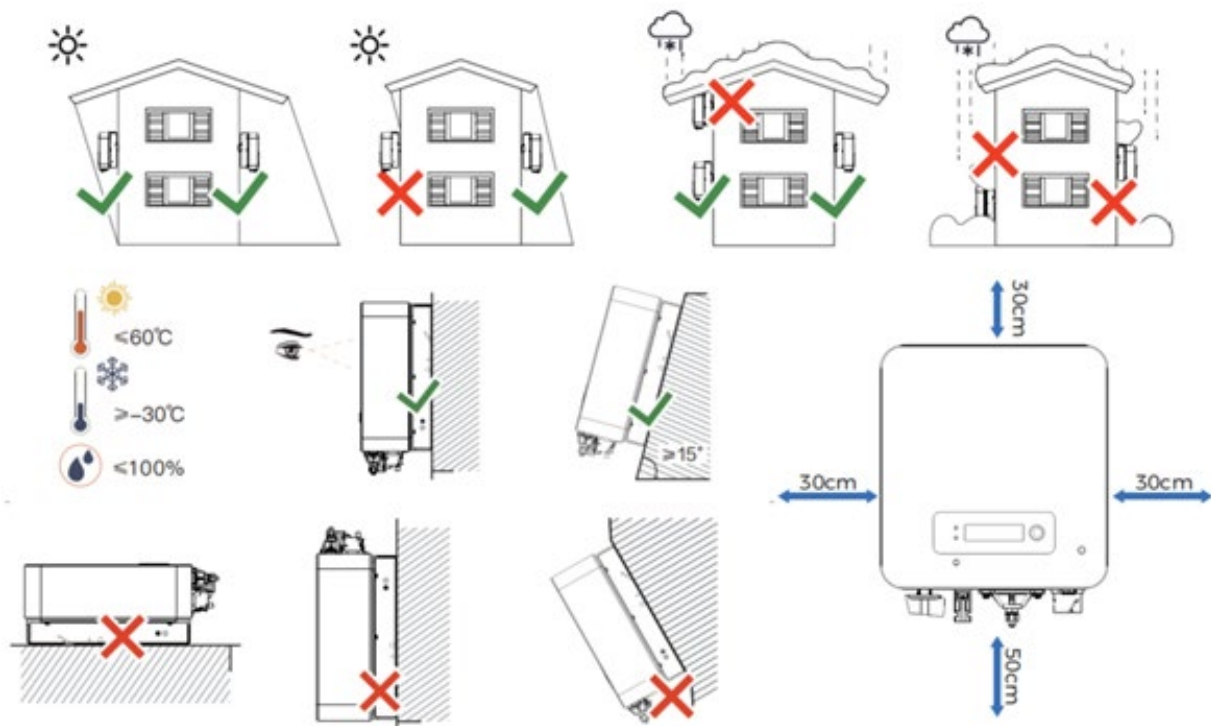


4.6. Installation position

	<p>Requirements for install position:</p> <ul style="list-style-type: none"> • Install position must not obstruct the disconnect of power. • Place the inverter on an appropriate bearing capacity object. • Location should be avoided touch by children.
<p>Note</p>	

Choose an appropriate installation location for the inverter.

Follow the requirements below to determine the installation position.



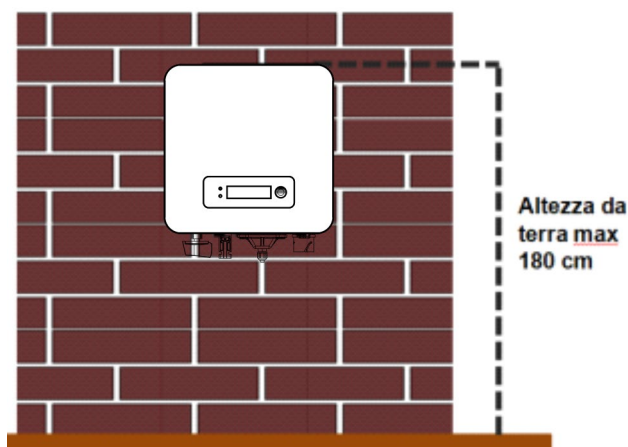


Figure 9 – Requirements or installing a single inverter

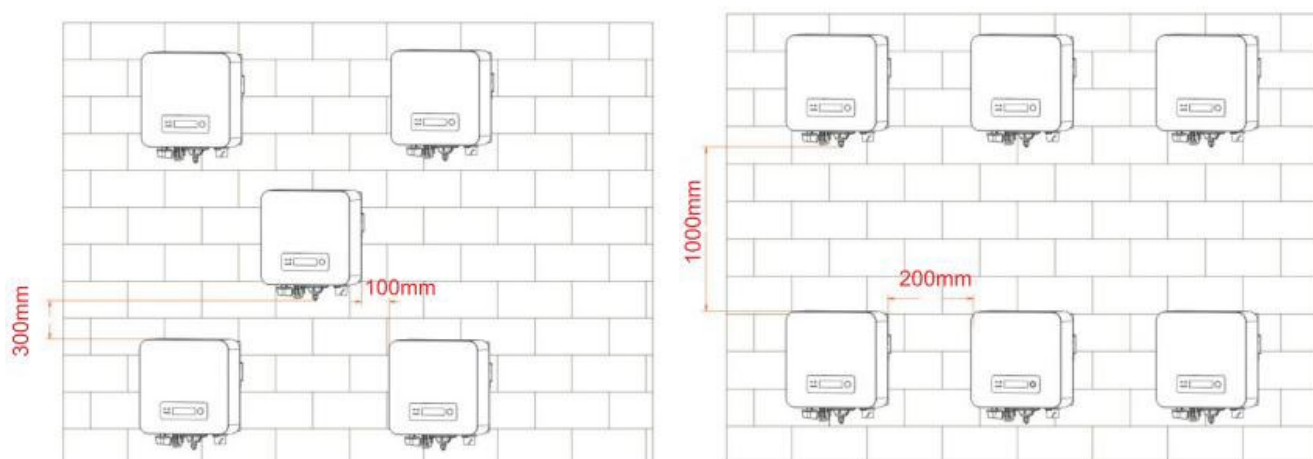


Figure 10 – Requirements for installing multiple inverters

For safety reasons, ZCS Spa and/or its partners may not carry out any technical repairs or maintenance work, or move the inverter from and to the ground if it is installed at a height of more than 180 cm from the ground.

Inverters installed at higher heights must be moved to the ground before they can be repaired or serviced.

4.7. Installing the 1PH 1100TL2-V3/1PH 5000TL2-V3 inverter

- 1) Determine the positions for drilling holes, ensure the hole positions are level, then mark the hole positions using a marker pen, use the hammer drill to drill holes on the wall. Keep the hammer drill perpendicular to the wall, do not shake when drilling, so as not to damage the wall. If the error of the hole positions is too big, you need to reposition.

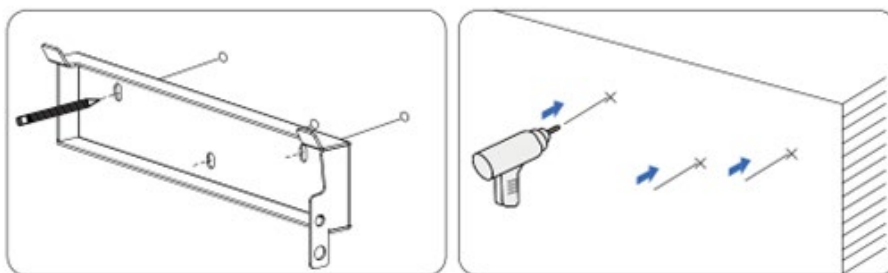
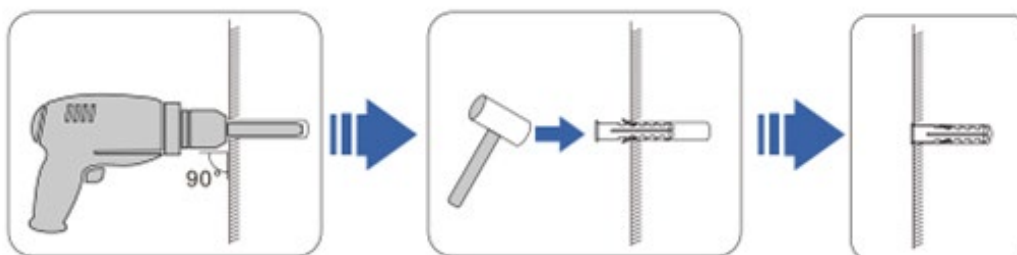
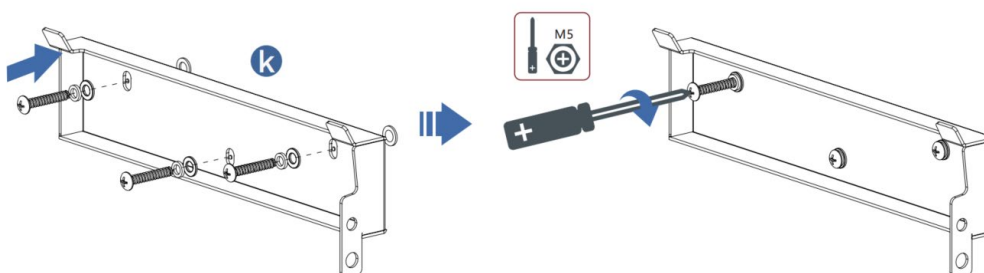


Figure 11 - Steps for mounting the inverter on the wall

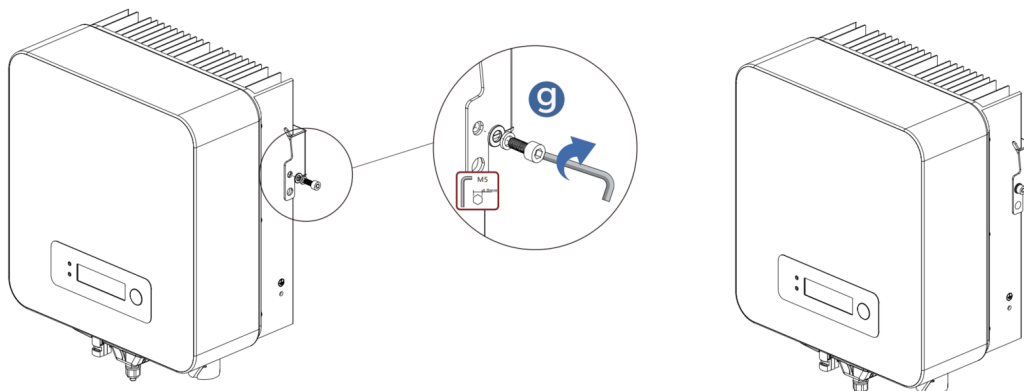
- 2) Insert the expansion bolt vertically into the hole, pay attention to the insertion depth of the expanding bolt (should be deep enough).



- 3) Align the rear panel with hole positions, fix the rear panel on the wall by tightening the expansion bolt with the nuts.



- 4) Hook the inverter to the rear panel. Using an M5screw to secure the inverter to the rear panel to ensure safety.





5. Electrical connections

General information in this chapter

This chapter describes the electrical connections of the 1PH 1100TL2-V3/1PH 5000TL2-V3 inverter. Carefully read this section before connecting the cables.

NOTE:

Before making any electrical connections, ensure that the DC circuit breaker is switched off. Please note that the capacitors in the inverter may remain electrically charged after the DC circuit breaker has been switched off. Therefore, it is necessary to wait at least 5 minutes to allow the capacitor to discharge completely.

	<ul style="list-style-type: none"> Installation and maintenance of the inverter must be performed by professional electrical engineer. For 1PH 1-4KTL-V3, the open-circuit voltage (Voc) of module arrays connected in series must be $\leq 550V$; for 1PH 5KTL-V3, the open-circuit voltage (Voc) of module arrays connected in series must be $\leq 600V$ The connected PV modules must have an IEC 61730 Class A rating.
Attention	
	<p>Dangerous DC voltage</p> <ul style="list-style-type: none"> Before establishing the electrical connection, cover the PV modules using opaque material or disconnect the PV generator from the inverter. Solar radiation will cause dangerous voltage to be generated by the PV generator. Before performing electrical connections, ensure that the DC switch is OFF. Reason is that the electrical charge remains in the capacitor after the DC switch has been switched off. Therefore, at least 5 minutes must lapse before the capacitor has been electrically discharged.
Danger	

Model	Isc PV (absolute maximum)	Maximum output over current protection
1PH 1.1KTL3-V3	25A	5.3A
1PH 1.6KTL3-V3	25A	7.7A
1PH 2.2KTL3-V3	25A	10.6A
1PH 2.7KTL3-V3	25A	13A
1PH 3KTL3-V3	25A	14.5A

1PH 3.3KTL3-V3	25A	16A
1PH 4KTL3-V3	25A	19.3A
1PH 5KTL3-V3	25A	24.1A

The decisive voltage class (DVC)

The DVC is the voltage of a circuit which occurs continuously between any two live parts in the worst-case rated operating condition when used as intended.

Interface	DVC
PV input interface	DVCC
AC output interface	DVCC
USB interface	DVCA
Com interface	DVCA

DC switch parameters	
Rated-insulation voltage	1100V
Rated impulse withstand voltage	8KV
Rated operational current (Ie)	1100V/5A, 1000V/8A, 800V/12.5A, 500V/25A
PV utilization category	DC-PV2
Rated short time withstand current (Icw)	700A
Rated short-circuit making capacity (Icm)	4xIe
Rated breaking capacity	4xIe

PV terminal parameters	
Rated-insulation voltage	1000V
Rated operational current	39A
Protection class	IP68
Maximum temperature limit	105°C



5.1. Connection sequence

Electrical installation is performed as follows:

1. Connect PE cable
2. Connect DC input cable
3. Connect AC output power cable
4. Connect communication cable (optional)



Figure 12 – Steps for connecting the cables

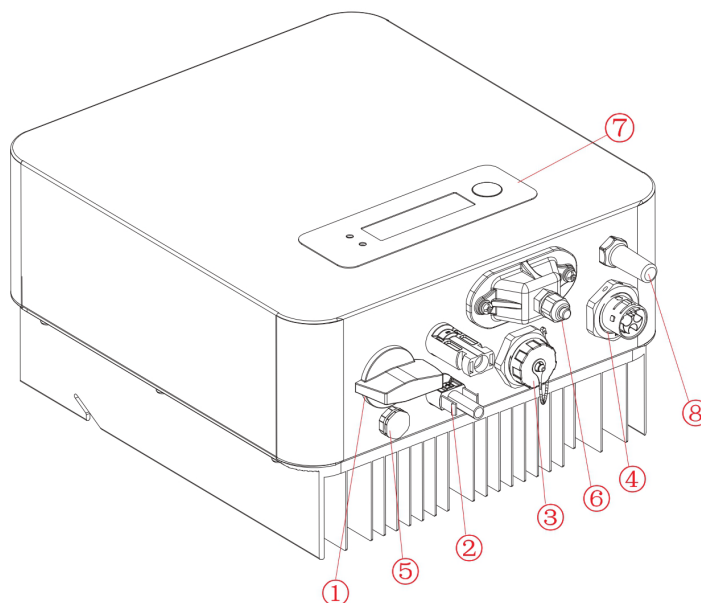
5.2. Terminal connector



Pay attention to damage during transport

- Please carefully check that the product packaging and each connection terminal are intact before installation.


Caution



No.	Label
1	DC Switch (optional)
2	PV input terminals
3	Wi-Fi/GPRS/Ethernet (optional)
4	Grid connection port
5	Breather valve
6	USB/DRMs/RS485/CT
7	LCD
8	Wi-Fi Antenna (optional)

5.3. Ground cable connections (PGND)

Connect the 1PH 1100TL2-V3/1PH 5000TL2-V3 inverter to the ground electrode using ground protection cables (PGND).

	<p>The inverter is transformer-less, requires the positive pole and negative pole of the PV array are NOT grounded. Otherwise, it will cause inverter failure. In the PV power system, all non-current carrying metal parts (such as PV module frame, PV rack, combiner box enclosure, and inverter enclosure) should be connected to the earth.</p>
Attention	

Prerequisites:

The PGND cables are prepared ($\geq 4\text{mm}^2$ outdoor power cables are recommended for grounding purposes), and the colour of the cable should be yellow-green.

Procedure:

1. Remove an adequate length of the external insulation layer using a wire stripper, as shown in Figure below.

Note: L2 is approximately 2- 3 mm longer than L1

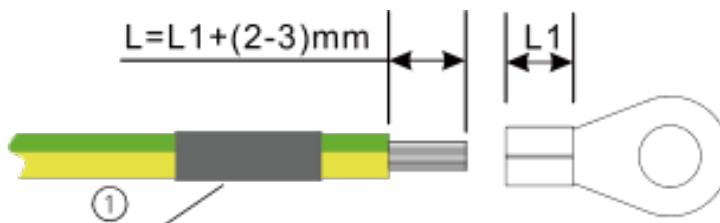


Figure 13 - Preparing the ground cable (1)

2. Insert the exposed wires in the OT terminal and crimp them using a crimping tool, as shown in Figure below.

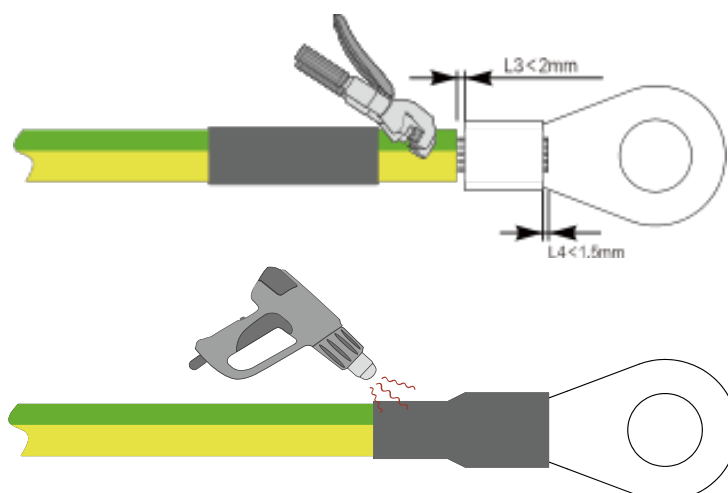


Figure 14 - Preparing the ground cable (2)

Note 1: L3 is the length between the insulation layer of the ground cable and the crimped part. L4 is the distance between the crimped part and core wires protruding from the crimped part.

Note 2: L4 is the distance between the crimped part and core wires protruding from the crimped part.

3. Install the crimped OT terminal and flat washer using the M5 screw in the hole located on the inverter heatsink, as shown in the figure; tighten the screw to a torque of 3 Nm using an Allen key.

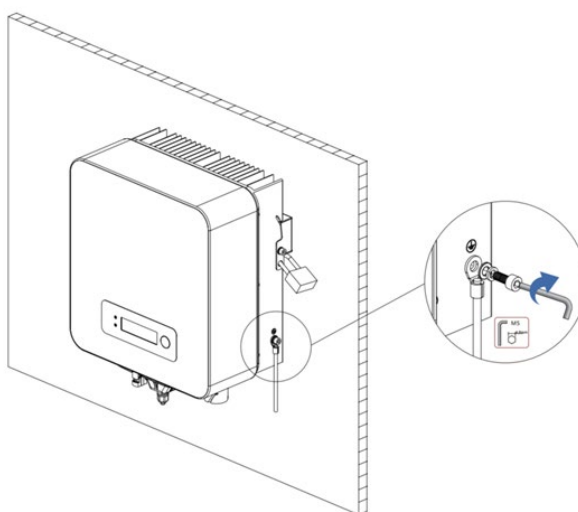


Figure 15 - Connecting the ground terminal



For improving anti-corrosion performance, after ground cable installed, apply silicone or paint is preferred to protect.

Note

5.4. Connecting the DC input power cables



Connect the 1PH 1100TL2-V3/1PH 5000TL2-V3 inverter to the photovoltaic strings using DC input power cables.

Connecting PV strings into inverter must follow the below procedure. Any faulty cause by inappropriate operation will be not included in the warranty.

Note

Depending on the type of inverter, select the appropriate inverter accessories (cables, fuse holder, fuse, switch, etc). The inverter associated with the PV array must offer excellent performance and reliable quality. The open-circuit voltage of the photovoltaic system must be lower than the maximum DC input voltage of the inverter. The output voltage of the strings must be compatible with the MPPT voltage range.

The positive and negative polarities of the panel on the inverter must be connected separately. The power cable must be suitable for photovoltaic applications.


	<ul style="list-style-type: none"> • Ensure the PV positive connector connects to the inverter positive pole, the negative connector connects to the inverter negative pole. Use the connectors in the accessories bag. The damage caused by incorrect is not included in the warranty. • Ensure the same PV string must have the same structure, including: same model, same number of panels, same direction, same azimuth.
Attention	
	<ul style="list-style-type: none"> • Before connecting the PV array to the inverter, make sure that the PV array is well insulated to ground. • Make sure that the voltage and the maximum short-circuit current of each PV string are within the permissible range of the inverter, see ‘Technical Data’ for details.
Warning	<ul style="list-style-type: none"> • Ensure that the ‘DC switch’ is in the OFF position. • Before connecting the DC connector to the inverter, please check the positive and negative polarity of the PV string and make sure it is correct before plugging the DC connector into the corresponding DC terminal. • Do not connect the same PV string to more than one inverter, otherwise it may cause damage to the inverter.

Recommended DC input cable size

Cross section (mm ² / AWG)		Outer diameter of cable (mm)
Range	Recommended value	
4.0-6.0 / 11-9	4.0 / 11	4.5 - 7.8

Table 1 - Recommended specifications for DC input cables

1. Use the metal contact pins from the accessories bag. Connect the cable according to the diagram (1. Positive cable, 2. Negative cable).
2. Insert the positive and negative DC cables into the corresponding contact pins.

	<ul style="list-style-type: none"> • Danger of reverse polarity, use the corresponding contact pins, ensure that the polarity is correct before plugging into the DC connections!
Caution	

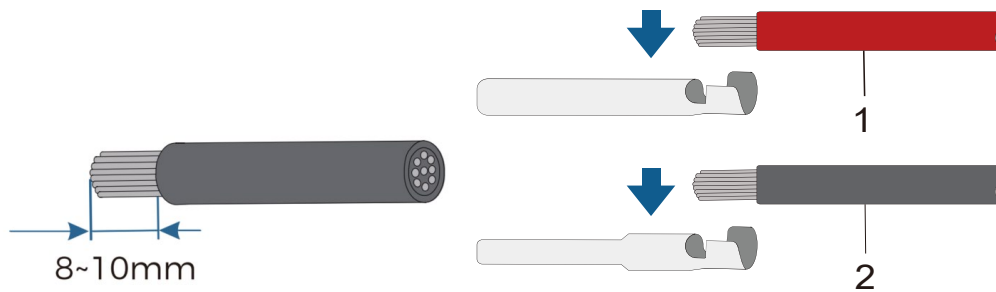


Figure 16 - Connecting the DC input power cables

3. Crimp the PV metal contact pin to the striped cable using proper crimping pliers.

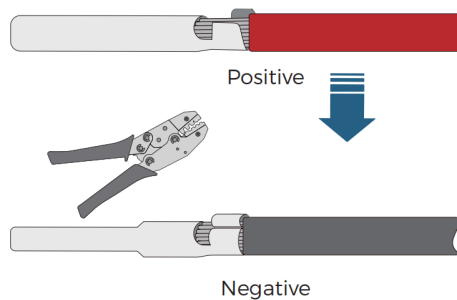


Figure 17 - Connecting the DC input power cables

4. Insert the crimped DC cables into the corresponding connector housing until you hear a clicking sound.

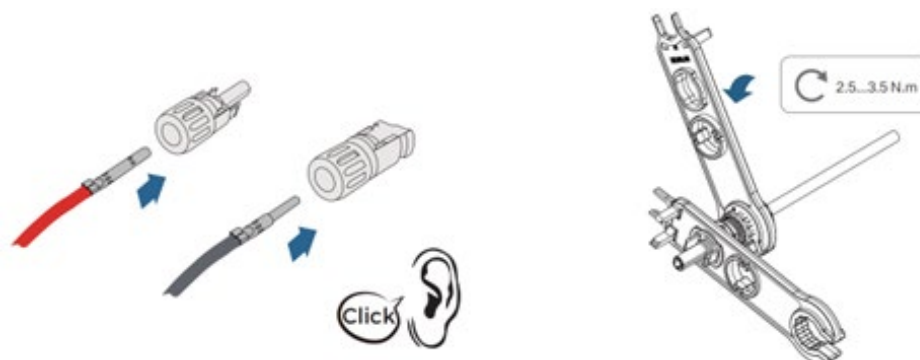


Figure 18 - Connecting the DC input power cables

5. Ensure the DC switch is in the 'OFF' position.

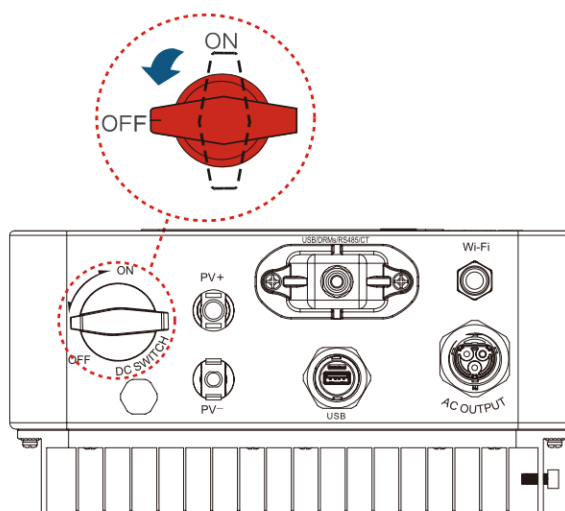


Figure 19 - Inverter OFF

6. Check the polarity of the DC input cable by measuring the PV voltage at the DC input with a multimeter. Ensure that the open circuit voltage does not exceed the inverter input limit of 600V under any circumstances.

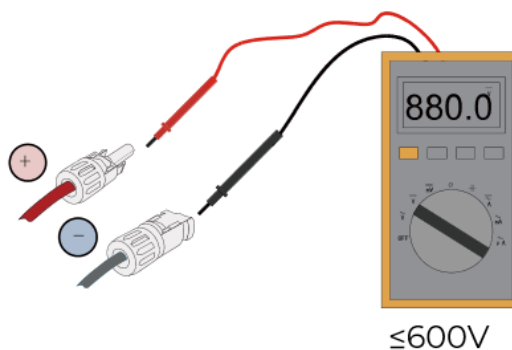


Figure 20 - Check with multimeter

7. Connect the DC connector to the inverter.

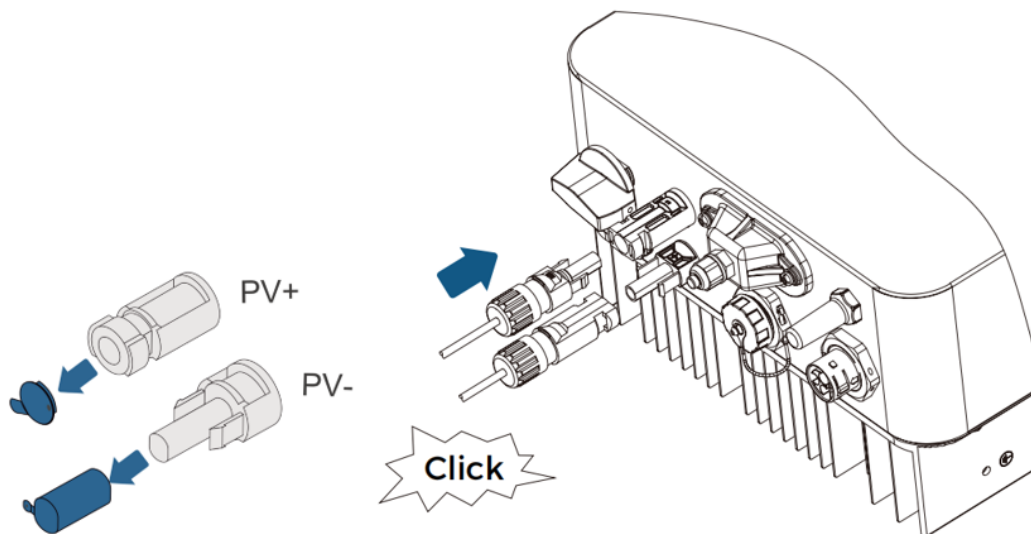



Figure 21 – DC connector to the inverter

	<p>For unconnected PV ports, do not remove the connector plug to prevent water.</p>
<p>Note</p>	

Removing the DC connector

If need to remove the PV connector from the inverter side, use the Removal Tool as shown below figure, move the connector gently.

A. Insert a removal key into the locking and press on the key with the adequate force.

	<p>Danger of DC arcing. Set the DC switch to OFF before removing the plus and minus connector.</p>
<p>Caution</p>	

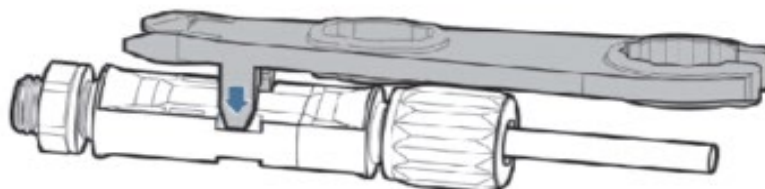




Figure 22 – Removing the DC connector

5.5. Connecting the AC output power cables

Connect the inverter to the AC power distribution network or power grid using AC power cables.

	<ul style="list-style-type: none"> • Each inverter must have its own circuit breaker. • Do not connect any consumers between the inverter and circuit breaker! • The AC disconnecting device must be easily accessible.
Caution	
	<p>Obtaining permission to connect to the grid</p> <ul style="list-style-type: none"> • The AC cable needs to meet the requirement of the local grid operator
Warning	

Context

The AC power cables used for the inverter must be three-pole outdoor cables. For easier installation, use flexible cables. The table lists the recommended specifications for cables and circuit breakers.

Item	1.1...1.6KTL3-V3	2.2KTL3-V3	2.7...4KTL3-V3	5KTL3-V3
Model				
Cable (Copper)	≥4mm ²	≥4mm ²	≥6mm ²	≥6mm ²
Breaker	16A/400V	25A/400V	25A/400V	30A/400V

Table 2 - Recommended specifications for AC output cables

Note: For safety reasons, make sure to use suitably sized cables, otherwise the current may cause overheating or overloading, which could result in a fire.

NOT allowed: connect loads between inverter and circuit breaker:

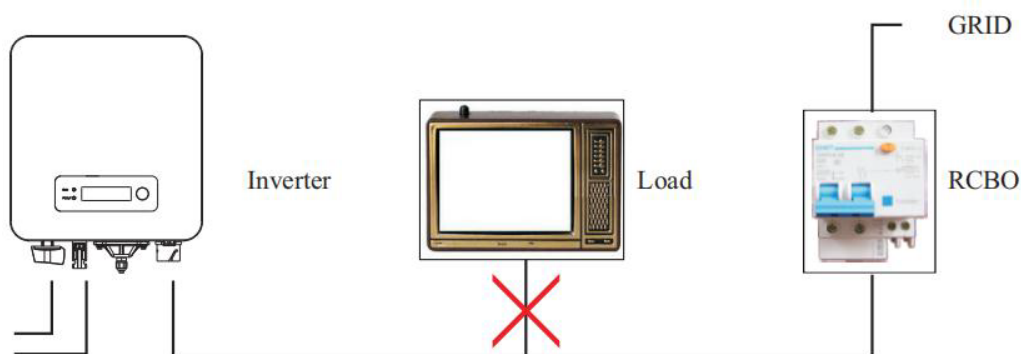


Figure 23 – Do not connect loads between the inverter and circuit breaker

AC cable should be correctly sized to ensure the power loss in AC cable is less than 1% of the rated power. If the resistance of the AC cable is too high, it will cause a huge increase in the AC voltage, which may lead to a disconnection of the inverter from the electrical grid. The relationship between power loss in AC cable and wire length, wire cross sectional area is shown in the following figure:

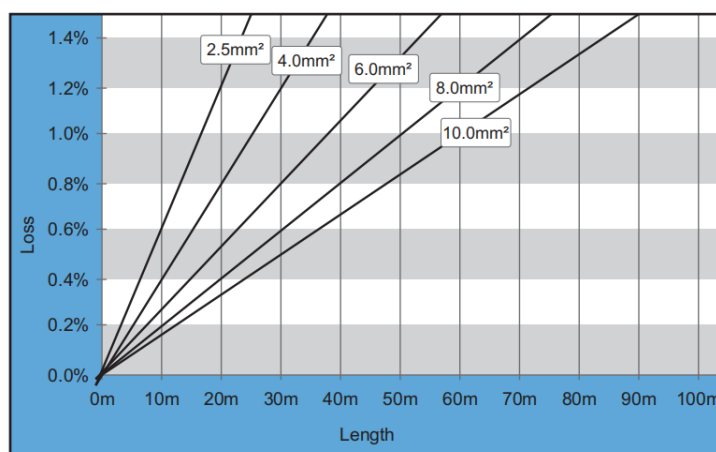
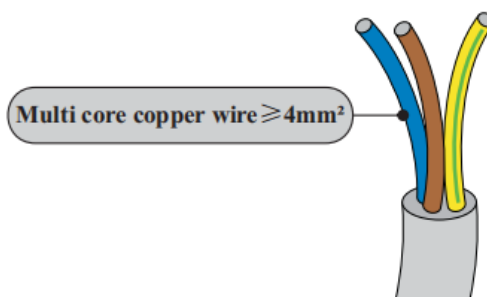


Figure 24 – Relationship between power loss, length and cable cross-section

The AC output of this product is equipped with a 3-pole terminal block connector. The inverter is equipped with IP66 AC connector, and the AC output cable needs to be wired by the customer.



Cable connection procedure

- 1) Select appropriate cables. Remove the insulation layer of the AC output cable using a wire stripper according to the figure shown below: A:15-25mm, B:6~8mm.

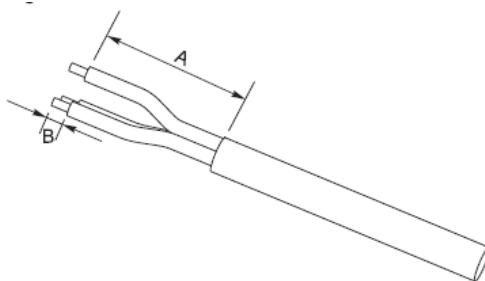


Figure 25 - Connecting the AC output cables (1)

- 2) Disassemble the AC connector according to the figure shown below: insert the AC output cable (with its insulation layer stripped according to step 1) through the waterproof locking cable gland.

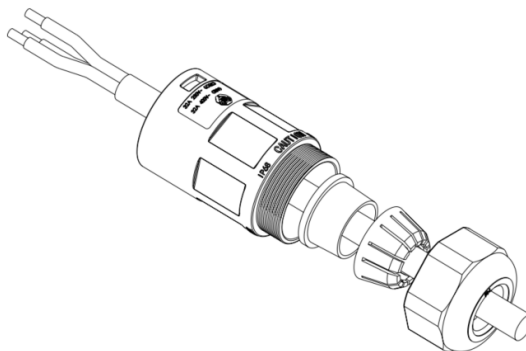


Figure 26 - Connecting the AC output cables (2)

- 3) Connect AC output cable as per the following requirements:

Connect the yellow-green wire to the hole labelled "PE", and fasten the wire using a Cross screwdriver;

Connect the brown wire to the hole labelled "L", and fasten the wire using a Cross screwdriver;

Connect the blue wire to the hole labelled "N", and fasten the wire using a Cross screwdriver.

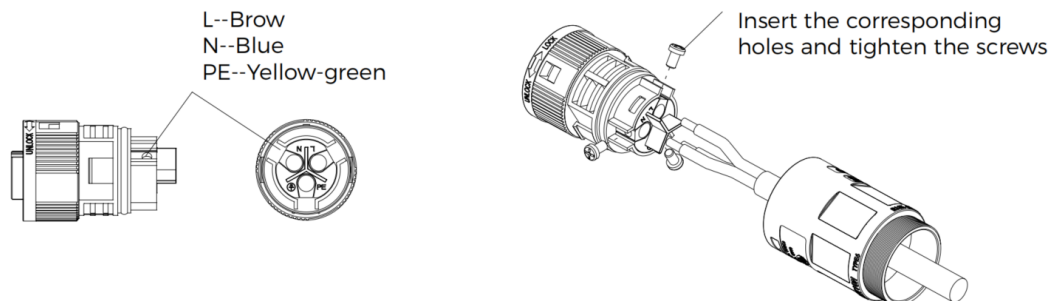


Figure 27 - Connecting the AC output cables (3)



Note

When using aluminium wire, you need to use a copper-aluminium transfer terminal. The copper terminal is included in the package.

- 4) Insert the AC connector and hear "click", then tighten the waterproof nut, to ensure that the cable is firmly connected:

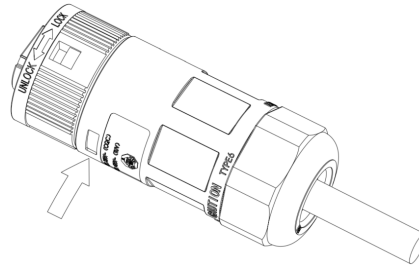


Figure 28 - Connecting the AC output cables (4)

- 5) Connect the AC connector to the inverter

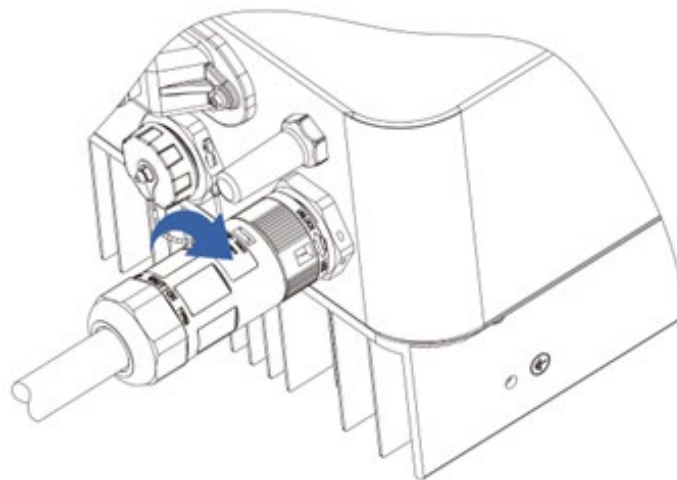


Figure 29 - Connecting the AC output cables (5)

Cable disconnect procedure

Disconnect the AC connector from the output terminal of the inverter, turning it in an anti-clockwise direction until the fixing device reaches its intended position, as shown below:

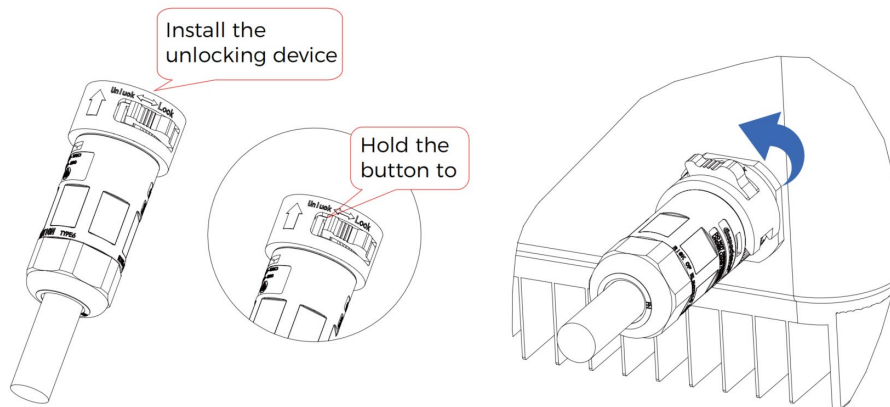


Figure 30 - Disconnecting the AC output cables



Warning

- **Make sure the grid is correctly disconnected before removing the AC connector.**



5.6. Connecting the communication cables

	<p>When layout the cable routing, separate the communication wiring and power wiring because the signal can be affected.</p>
<p>Note</p>	

The figure below shows the arrangement of the communication ports on the inverters

1PH 1100TL2-V3/1PH 5000TL2-V3.

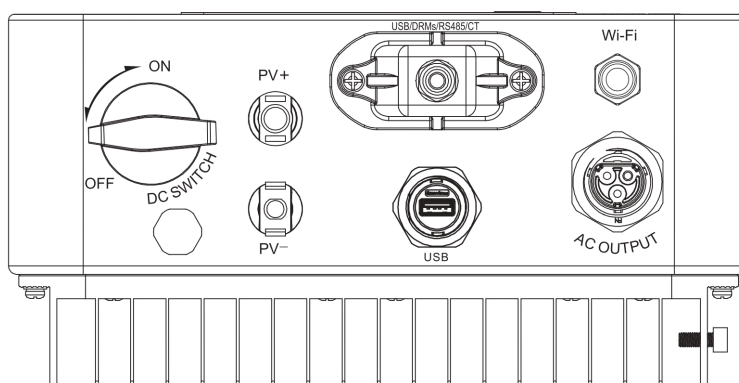


Figure 31 - Arrangement of communication ports

RS485, CT, inverter logic interface connection

Recommended communication cable size are shown below. The wiring methods are the same for RS485 and CT, this part describes their wiring methods and logic interface wiring method.

Communication ports	RS485	CT
Cable cross-section	0.5 - 1.5 mm ²	0.5 - 1.5 mm ²
Outer diameter	2.5~6 mm	2.5~6 mm

Table 3 - Recommended specifications for communication cables



- 1) Remove the central waterproof cover of the communication terminal block using a star screwdriver;

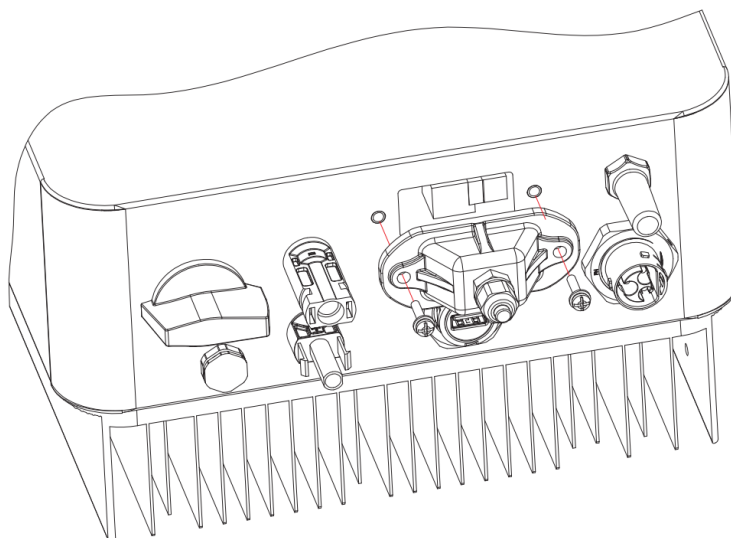


Figure 32 – Removing the central cover

- 2) Turn the waterproof cable gland; remove the cap in the waterproof cable gland;

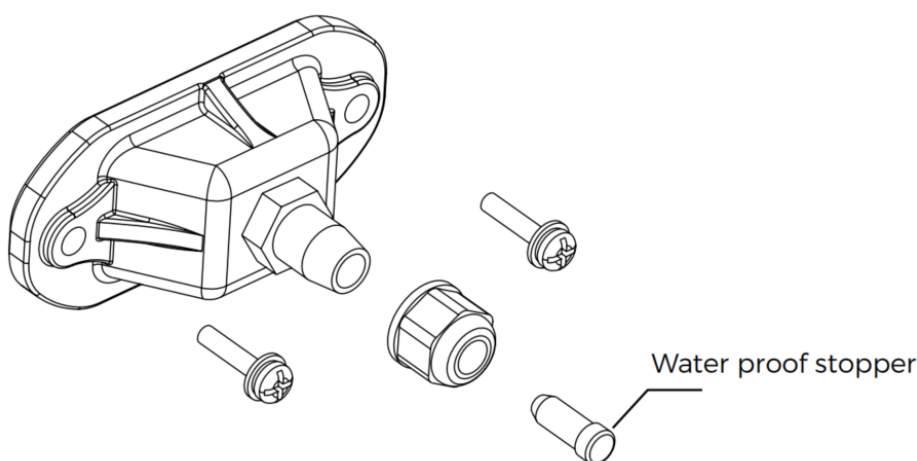


Figure 33 – Removing the cable glands and stoppers

Note: The waterproof connectors refer respectively to (from left to right): RS485 and CT. Remove the waterproof connectors according to the communication functions to be used. DO NOT remove the unused connectors.

- 3) Choose a suitable cable according to Table and remove the outer insulation part using a cable stripping tool (6 mm); thread the cable through the cable gland and the waterproof cable glands.
- 4) Choose the terminal according to Table 4, connect the cables as shown in the labels and secure them using a flat screwdriver.

Note: keep the unused terminals for future use.

Function Description of the communication terminals:



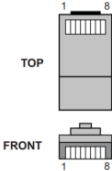
Type	RS485		CT		Logic interface
connector					
Label	TX-	TX+	CT-	CT+	The following table
Function	RS485 differential signal-	RS485 differential signal+	CT-	CT+	

Table 4 - Description of the communication terminals and their function

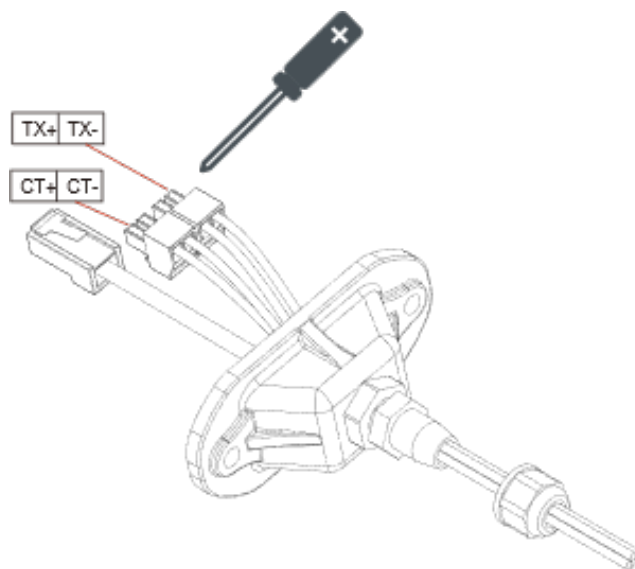


Figure 34 - Tightening the terminals on the cables

The logic interface pin definitions and circuit connections are as follows:

The function of the logical interface needs to be set on the display screen, please refer to the appropriate operation.


- A. Logic interface pins are defined according to different standard requirements. Logic interface for AS/NZS 4777.2:2015, also known as inverter demand response modes (DRMs).

The inverter will detect and initiate a response to all supported demand response commands within 2s. The inverter will continue to respond while the mode remains asserted



Function description of the DRMs terminal:

Pin No.	Color	Function
1	White and orange	DRM1/5
2	Orange	DRM2/6
3	White and green	DRM3/7
4	Blue	DRM4/8
5	White and blue	RefGen
6	Green	DRM0
7	White and brown	Pin7&Pin8 short internal
8	Brown	

	<p>Supported DRM commands: DRM0, DRM5, DRM6, DRM7, DRM8.</p>
<p>Note</p>	

B. Logic interface for VDE-AR-N 4105:2018-11, is in order to control and/or limit the inverter's output power.

The inverter can be connected to an RRCR (Radio Ripple Control Receiver) in order to dynamically limit the output power of all the inverters in the installation.

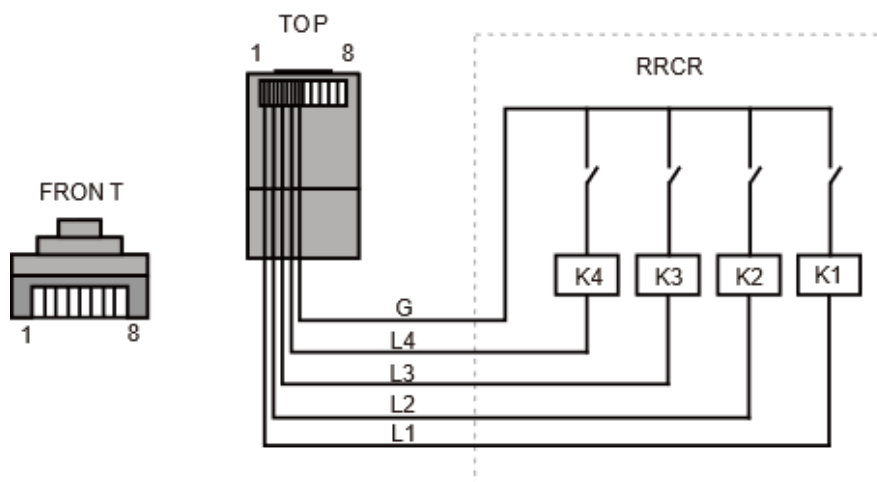


Figure 35 – Inverter: RRCR Connection



Function description of the terminal

Pin No.	Pin name	Description	Connected to (RRCR)
1	L1	Relay contact 1 input	K1 - Relay 1 output
2	L2	Relay contact 2 input	K2 - Relay 2 output
3	L3	Relay contact 3 input	K3 - Relay 3 output
4	L4	Relay contact 4 input	K4 - Relay 4 output
5	G	GND	Relays common node
6	NC	Not Connected	Not Connected
7	NC	Not Connected	Not Connected
8	NC	Not Connected	Not Connected

The inverter is preconfigured to the following RRCR power levels

Relay status: close is 1, open is 0

L1	L2	L3	L4	Active Power	Cos(φ)
1	0	0	0	0%	1
0	1	0	0	30%	1
0	0	1	0	60%	1
0	0	0	1	100%	1

- C. Logic interface for EN50549-1:2019, is in order to cease active power output within five seconds following an instruction being received at the input interface.

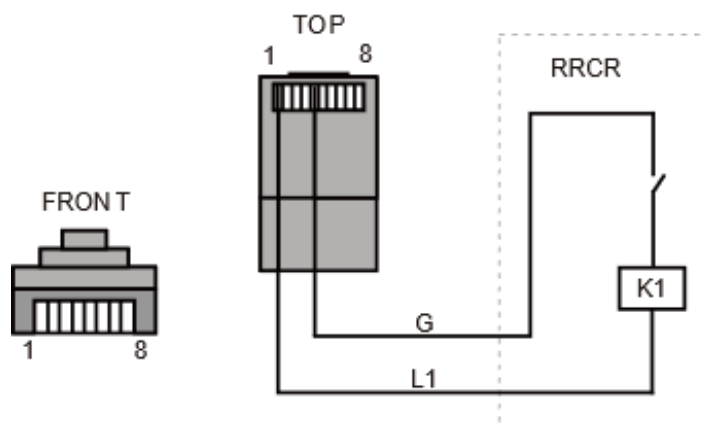


Figure 36 - Inverter: RRCR Connection

Function description of the terminal

Pin No.	Pin name	Description	Connected to (RRCR)
1	L1	Relay contact 1 input	K1 - Relay 1 output
2	NC	Not Connected	Not Connected
3	NC	Not Connected	Not Connected
4	NC	Not Connected	Not Connected
5	G	GND	K1 - Relay 1 output
6	NC	Not Connected	Not Connected
7	NC	Not Connected	Not Connected
8	NC	Not Connected	Not Connected

The inverter is precon figured to the following RRCR power levels.

Relay status: close is 1, open is 0

L1	L2	L3	L4
1	0%	< 5 seconds	1
0	100%	/	1

- 5) Insert the terminal as per the printed label, and then tighten the screws to fix the waterproof cover, rotate the cable gland clockwise to fasten it securely.

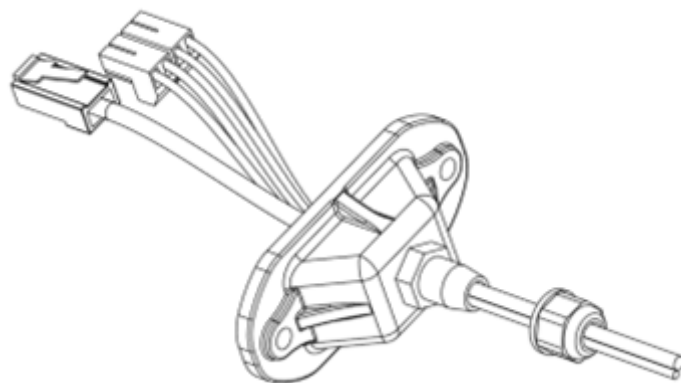


Figure 37 - Closing the central door

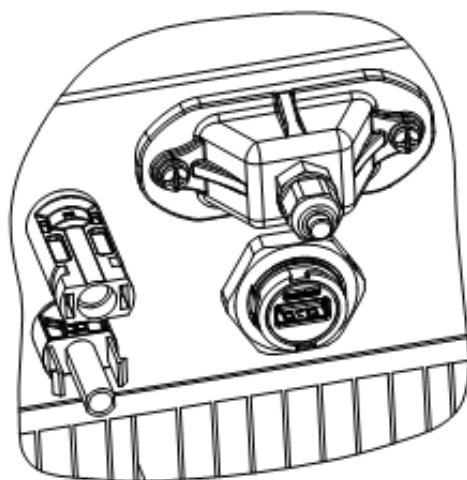
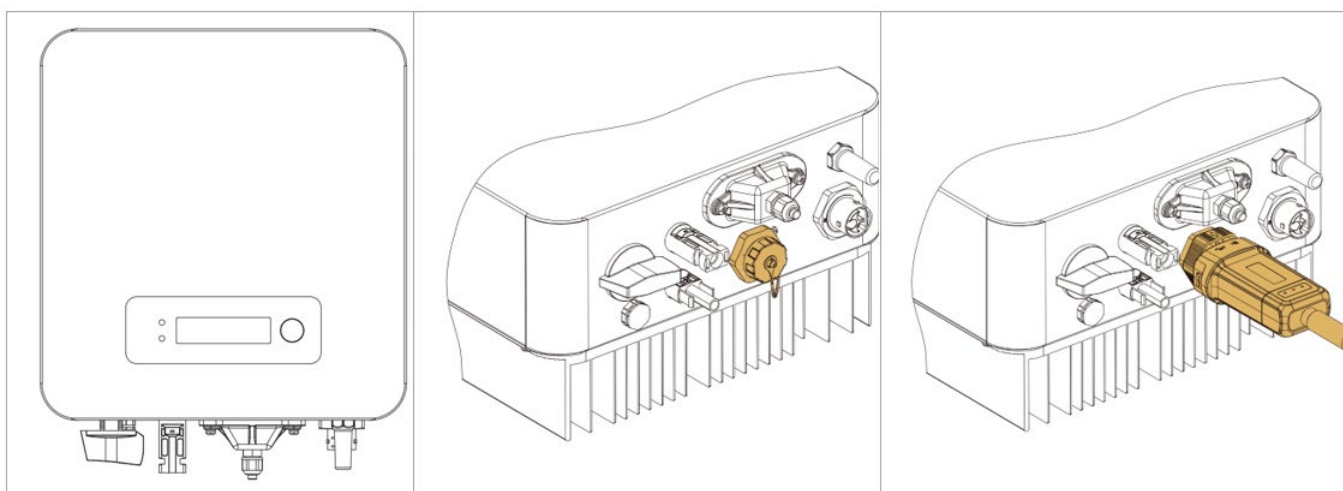


Figure 38 - Closing the central door

WiFi/GPRS module installation procedure


The data collector transmits the power output information, alarm information and operation status of the inverter to the PC or local data collection device, and then uploads them to the server. According to the monitoring device SN, remote monitoring of the inverter is carried out on the relevant website or APP.

External WiFi/GPRS module connection



6. Commissioning the inverter

6.1. Safety inspection before commissioning

	<p>Pre-commissioning checks</p> <ul style="list-style-type: none"> • Before starting up the device for the first time, all operations performed on the device should be thoroughly checked. • Ensure that DC and AC voltages are within the acceptable range of the inverter.
Attention	

- **Photovoltaic strings**

Before turning on the inverter, it is necessary to examine the photovoltaic string. Check the open-circuit voltage of each photovoltaic panel and compare it with the data in the technical datasheet.

- Make sure that the open-circuit voltage of each PV string corresponds to the technical data and that it is lower than the maximum input voltage permitted by the inverter
- Make sure that the positive and negative polarities are correct.

- **DC Connection**

Use the multi-meter to check the voltage on the DC side; check the DC cable, make sure that the positive and negative polarities are not inverted, and are consistent with the positive and negative polarities of the photovoltaic string.

- **AC Connection**

Make sure that the AC switch of the inverter is off. Check that the inverter is connected to the grid properly. Check that the phase voltage is within the correct range. If possible, measure the THD; if there is too much distortion, the inverter may not operate.

6.2. Starting the inverter

- 1) Turn ON the DC switch both on the field panel and on the photovoltaic inverter; wait for the screen to turn on.
- 2) Turn ON the AC switch installed on the wall.

When the photovoltaic string generates enough direct current, the inverter will start automatically. The word “normal” shown on the screen will indicate the correct functioning of the inverter.

- 3) Set the correct country code (refer to related chapter of this manual).

Note: Different grid operators in different countries require different specifications regarding the grid connections of PV inverters. Therefore, it is very important to select the correct country code according to the requirements of the local authorities.

If in doubt, consult the system engineer or a qualified electrician.

Zucchetti Centro Sistemi S.p.A. shall not be held responsible for any consequences resulting from the incorrect selection of the country code.

If the inverter indicates the presence of any faults, refer to related chapter of this manual or contact the Zucchetti Centro Sistemi S.p.A. technical support.

7. Operating interface

General information in this chapter

This section describes the display and its operation, as well as the buttons and LED indicators of the 1PH 1100TL2-V3/1PH 5000TL2-V3 inverters.

7.1. Operating panel and display

Buttons and LED indicators



Figure 37 – LCD display with buttons and LED indicators

Single button:

Button	Description
Long press	Enter the next menu or confirm the selection
Short press	Achieve the next page turning function

Indicator lights:

LED			Description
POWER	Green	Light up	Normal state
		Flashes	Wait or Check state
FAULT	Red	Light up	GFCI ground leakage fault or low insulation resistance alarm
ALARM	Red	Light up	Recoverable fault or permanent fault state

7.2. Main interface

Below are some examples of the main screen, obtained by short pressing the key.

<ul style="list-style-type: none"> • PV 1 input voltage and current 	<ul style="list-style-type: none"> • Grid voltage and current
<ul style="list-style-type: none"> • PV generated power 	<ul style="list-style-type: none"> • Grid voltage and frequency
<ul style="list-style-type: none"> • Today generated electricity 	<ul style="list-style-type: none"> • Wi-Fi/RS-485 status
<ul style="list-style-type: none"> • Total generated electricity 	<ul style="list-style-type: none"> • Inverter faulty alarm

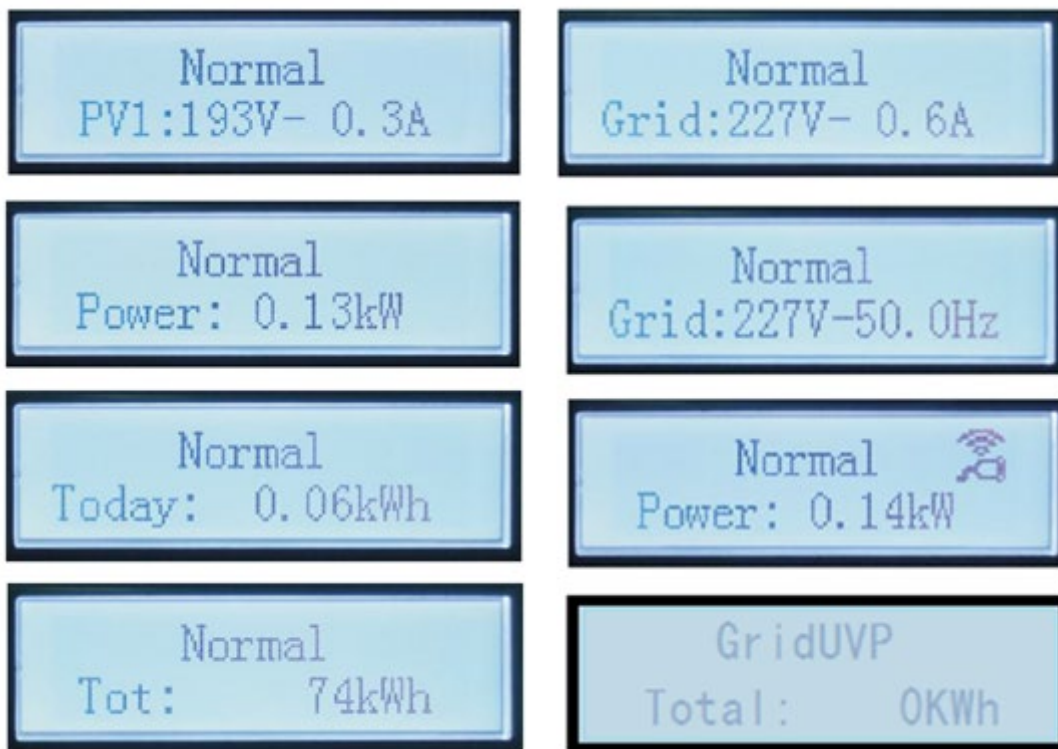
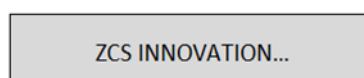
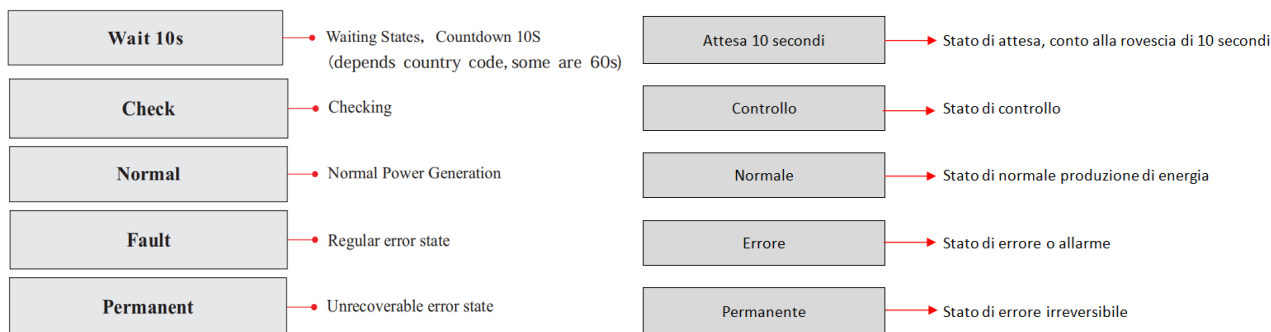


Figure 38 - Example of main screens on the display

At start up, the LCD screen displays “ZCS INNOVATION...,” as shown in the figure below, when the control board is correctly connected to the communication board, the LCD display will show the current status of the inverter, as shown in the figure below.



When control board successfully connected with communication board, the LCD display the current state of the inverter, display as shown in the figure below:



Inverter statuses include:

The following table displays the various statuses and their meanings:

Status	Description
Wait	The inverter is waiting to Check State when reconnecting the system. In this state, the grid voltage value is between the max and min limits and so on; If not, Inverter will go to Fault State or Permanent State.
Check	The inverter is checking isolation resistors, relays, and other safety requirements. It also does self-test to ensure inverter software and hardware are well-functional. The inverter will go to Fault State or Permanent State if any error or fault occurs.
Normal	The inverter enters to Normal State, feeding power to the grid; the inverter will go to a Fault State or Permanent state if any error or fault occurs.
Fault	The inverter has encountered a recoverable error. It should recover if the errors disappear. If the Fault State continues; please check the inverter according to the error code.
Permanent	<p>The inverter has encountered an unrecoverable error, we need maintainer debug this kind of error according to the error code.</p> <p>When the control board and communication board connection fails, the LCD display interface as shown in the figure below:</p> <div style="border: 1px solid gray; padding: 5px; text-align: center; margin: 10px auto; width: fit-content;"> DSP communicate fail </div>




7.3. Main menu

Long press (3 seconds) the button when you are in the main interface screen to enter the main menu, which will appear as follows:

Sub menu	What can do here
1. Enter Setting	Change device settings
2. Event list	Display the current event list and the event history
3. SystemInfo	Display system information
4. System time	Display the current system time
5. Software update	Perform a software update

Enter Setting

Long press the button to enter the main interface of "1. Enter Setting" and long press the button to enter the setting menu.

	<p>Long press the button to enter the main interface of "1. Enter Setting" and long press to enter the setting menu. You can select the content you want to set by short pressing the button.</p> <p>Note 1: Some settings need to enter the password (the default password is 0001). When entering the password, short press to change the number, long press to confirm the current number, and long press after entering the correct password. If "password error, try again" appears, you will need to re-enter the correct password.</p>
Note	

Menu	Description
1. Set Time	Set the system time for the inverter.
2. Clear Energy	Clean the inverter of the total power generation.
3. Clear Events	Clean up the historical events recorded in the inverter.
4. Enset Country	Enable this option before setting the country. Attention: when the inverter is working for power generation over 24h, country setting is forbidden; it can only be set after LCD setting. Key in passwords for country setting through LCD

Menu	Description
	(default: 0001), country setting can be set in 24h after keying in the correct passwords, over 24h, set through LCD again
5. Set Country	Set up the safety regulation country that meet the current use conditions and requirements. Before setting this item, ensure that the “Enset Country” option is enabled. Please refer to “4. Enset Country” for details.
6. On-Off Control	Inverter on-off local control.
7. Set Energy	Set the total power generation. You can modify the total power generation through this option.
8. Set address	Set the address (when you need to monitor multiple inverters simultaneously). Default 01.
9. Set Input mode	The input modes of the ZCS inverter are divided into parallel mode and independent mode (when multi-channel MPPT is input). Since 1PH 1100TL2-V3/1PH 5000TL2-V3 has only one group of MPPT input, the input modes are not distinguished.
10. Set Language	Set the inverter display language.
11. Set Start Parameter	Set relevant parameters according to requirements.
12. Set Safety Voltage	Set relevant parameters according to requirements.
13. Set Safety Frequency	Set relevant parameters according to requirements.
14. Set Insulation	User can modify the above 4 parameters of the machine through the SD card, and the user needs to copy the parameter information that needs to be modified into the SD card in advance. Note: To enable this feature, please contact the Zucchetti Centro Sistemi S.p.a. technical support.
15. Set Reactive	Enable or disable reactive functions.
16. Set Power Derate	Enable or disable the power derate function of the inverter, and set the derate ratio
17. Set RefluxP	Enable or disable the anti-reflux function of the inverter, and set the reflux power. This function needs to be used with external CT, please refer to this manual 4.5 RS485, CT, inverter logic interface connection for details.
18. MPPT Scan	Shadow scanning, when the component is blocked or abnormal, causing multiple power peaks, by enabling this function, the peak point of maximum power can be tracked.
19. Start Time	Startup time and recovery reconnection time can be set.

Menu	Description
20. Set ElecMeter	Enable or disable meter functions.
21. Hard Reflux	If the power exceeds the anti backflow setting, the machine will be disconnected from the grid.
22. Input Safety	After inserting the USB drive, update the safety parameter file inside the USB drive.
23. LogicInterfac	Enable or disable logical interfaces. Please refer to this manual 4.5 RS485, CT, inverter logic interface connection for details. Set the generation ratio.

1. Date and time

Select “1. Date and time” and long press the key to enter the menu for setting the date/time. First set the date and then the time by short pressing the key to change the number in a progressive manner. Long press the key to move to the next digit. The date and time are expressed in the format: 20YY – MM - DD HH:MM:SS.

The display will show “OK” if the setting is correct and “Error” in case of an error. The date and time are visible in the submenu “4. Time” in the main menu.

2. Clear Energy

Select “2. Reset Energy” and long press the key to enter the menu for deleting the energy data and in particular the daily and total energy produced, which is shown in the main interface. The display will show “Enter PWD!”; enter the password “0001” by short pressing the key to increase the selected digit. Long press the key to move to the next one and confirm. If the display shows, “Error, try again!” press the key again and enter the password again. When the password entered is correct, the inverter will delete the data relating to the energy produced and the display will show “OK” if the setting is successful.

3. Clear Events

Select “3. Clear Events” and long press the key to enter the menu for clearing historical events, i.e. to delete all error warnings present in the “List of historical events” submenu. Long press the key to start the procedure; the display will show “OK” if the operation is successful.

4. Enset country

Select “4. Enset country” and long press the key to enter the menu for enabling this country code. The display will show “Enter PWD!”; enter the password “0001” by short pressing the key to increase the selected digit. Long press the key to move to the next one and confirm. If the display shows, “Error, try again!” press the key again and enter the password again. When the password entered is correct, you can enter the menu.

This operation must be carried out if you want to change the Country code and it has not been changed during the last 24 hours of operation of the inverter.

5. Setting of country codes

Select “5. Set Country” and long press the key to enter the menu for setting the national grid regulations. If “Setting disabled” appears, go to point “7. Enable Country” to enable this function. Once the function has been enabled, repeat the above steps and set the code relating to the desired national regulations. Short press the key to increase the selected digit and long press the key to move to the next one and confirm. The display will show “OK” if the setting is successful. The current country code can be checked from the “System Info” menu.

Note: The change of the country code will take effect after the next start-up of the inverter.

For more information and to know the country regulations on board the inverter, refer to the following table.

Code		Country	Code		Country
000	000	Germany VDE4105	018	000	EU EN50438
	001	Germany BDEW		001	EU EN50549
	002	Germany VDE0126	019	000	IEC EN61727
001	000	Italia CEI-021 Internal	020	000	Korea
	001	Italia CEI-016 Italia	021	000	Sweden
	002	Italia CEI-021 External	022	000	Europe General
	003	Italia CEI0-21 In Areti	024	000	Cyprus
002	000	Australia	025	000	India
	001	Australia AU-WA	026	000	Philippines
	002	Australia AU-SA	027	000	New Zealand
	003	Australia AU-VIC	028	000	Brazil
	004	Australia AU-QLD		001	Brazil LV
	005	Australia AU-VAR		002	Brazil 230
	006	Australia AUSGRID		003	Brazil 254
	007	Australia Horizon	029	000	Slovakia VSD
003	Spain RD1699	001		Slovakia SSE	
004	Turkey	002		Slovakia ZSD	
005	000	Denmark	033	000	Ukraine
	001	Denmark TR322	035	000	Mexico LV
006	000	Greece Continent	038	000	Wide-Range-60Hz
	001	Greece island	039	000	Ireland EN50438
007	000	Netherland	040	000	Thailand PEA
008	000	Belgium		001	Thailand MEA
009	000	UK G59/G99	042	000	LV-Range-50Hz

Code		Country	Code		Country
	001	UK G83/G98	044	000	South Africa
010	000	China	046	000	Dubai DEWG
	001	China Taiwan		001	Dubai DEWG MV
011	000	France	107	000	Croatia
	001	France FAR Arrete23	108	000	Lithuania
012	000	Poland			

Table 5 – Country Codes

6. On-Off control

Select “6. On-Off control” and long press the key to enter the menu for setting the energy already produced by the photovoltaic system. The display will show “Enter PWD!”; enter the password “0001” by short pressing the key to increase the selected digit. Long press the key to move to the next one and confirm. If the display shows, “Error, try again!” press the key again and enter the password again. When the password entered is correct, you can enter the menu. You can now abilities the inverter on-off local control.

7. Set Energy

Select “7. SetEnergy” and long press the key to enter the menu for setting the energy already produced by the photovoltaic system. The display will show “Enter PWD!”; enter the password “0001” by short pressing the key to increase the selected digit. Long press the key to move to the next one and confirm. If the display shows, “Error, try again!” press the key again and enter the password again. When the password entered is correct, you can enter the menu. You can now set the amount of energy already produced by the system before installing the current inverter, which is visible from the main interface.

8. Set Address

Select “8. Set Address” and long press the key to enter the menu for selecting the communication address. Short press the key to increase the selected digit and long press the key to move to the next one and confirm. The display will show “OK” if the setting is successful.

The Modbus address indicates the address used by the inverter to send its data to the monitoring server. Address 01 is used for single inverters; to extend the monitoring to multiple inverters, use progressive communication addresses.

Note: make sure that the address entered is never 00, because this setting would exclude the possibility of communication between the inverter and Wi-Fi network.

9. Set Input mode

The input modes of the ZCS inverter are divided into parallel mode and independent mode (when multi-channel MPPT is input). Since 1PH 1100TL2-V3/1PH 5000TL2-V3 has only one group of MPPT input, the input modes are not distinguished.

10. Set Language

Select “10. Set Language” and long press the key to enter the menu for selecting the Language. Select the language by short pressing the key, then long press the key to confirm.

If the operation is successful, “OK” will be displayed; otherwise, “Error” will be displayed.

In the current firmware version (V1.00), the languages available are: Chinese, English, Italian, German, French and Portuguese; future firmware updates may add new languages.

11. Set Start Parameters

The user can change the start parameters directly from the LCD display. The user must first copy the TXT files to the SD card. These files can be requested from Zucchetti Centro Sistemi Spa technical support.

Select “11. InitParameters” and long press the key to enter the menu for setting the start parameters. The display will show “Enter PWD!”; enter the password “0001” by short pressing the key to increase the selected digit. Long press the key to move to the next one and confirm. If the display shows, “Error, try again!” press the key again and enter the password again. When the password entered is correct, you can enter the menu. The new start parameters will now be loaded onto the inverter automatically.

If the setting is successful, “OK” will be displayed; otherwise, “Error” will be displayed.

Attention: do not enter this menu if the microSD card is not inserted in the appropriate slot of the inverter or if the correct TXT files have not been copied to it.

12. Safety Voltage

The user can change the value of the protection voltage directly from the LCD display. The user must first copy the TXT files to the SD card. These files can be requested from ZCS technical support.

Select “12. Safety Voltage” and long press the key to enter the menu for setting the protection voltage. The display will show “Enter PWD!”; enter the password “0001” by short pressing the key to increase the selected digit. Long press the key to move to the next one and confirm. If the display shows, “Error, try again!” press the key again and enter the password again. When the password entered is correct, you can enter the menu. The new protection voltage will now be loaded on the inverter automatically.

If the setting is successful, “OK” will be displayed; otherwise, “Error” will be displayed.

Attention: do not enter this menu if the microSD card is not inserted in the appropriate slot of the inverter or if the correct TXT files have not been copied to it.

13. Set Safety Frequency

The user can change the value of the protection frequency directly from the LCD display. The user must first copy the TXT files to the SD card. These files can be requested from ZCS technical support.

Select “13. Safety Hz” and long press the key to enter the menu for setting the protection frequency. The display will show “Enter PWD!”; enter the password “0001” by short pressing the key to increase the selected digit. Long press the key to move to the next one and confirm. If the display shows, “Error, try

again!" press the key again and enter the password again. When the password entered is correct, you can enter the menu. The new protection frequency will now be loaded on the inverter automatically. If the setting is successful, "OK" will be displayed; otherwise, "Error" will be displayed.

Attention: do not enter this menu if the microSD card is not inserted in the appropriate slot of the inverter or if the correct TXT files have not been copied to it.

14. Set Insulation

The user can change the value of the insulation resistance directly from the LCD display. The user must first copy the TXT files to the SD card. These files can be requested from ZCS technical support.

Select "14. Insulation" and long press the key to enter the menu for setting the insulation resistance. The display will show "Enter PWD!"; enter the password "0001" by short pressing the key to increase the selected digit. Long press the key to move to the next one and confirm. If the display shows, "Error, try again!" press the key again and enter the password again. When the password entered is correct, you can enter the menu. The new insulation resistance will now be loaded on the inverter automatically. If the setting is successful, "OK" will be displayed; otherwise, "Error" will be displayed.

Attention: do not enter this menu if the microSD card is not inserted in the appropriate slot of the inverter or if the correct TXT files have not been copied to it.

15. Set Reactive Power

Select "15. Set Reactive" and long press the key to enter the menu for setting the reactive power component produced. The display will show "Enter PWD!"; enter the password "0001" by short pressing the key to increase the selected digit. Long press the key to move to the next one and confirm. If the display shows, "Error, try again!" press the key again and enter the password again. When the password entered is correct, you can enter the menu. At this point, short press the key to select the option "1.Enable" or "2.Disable" and confirm the selection by long pressing the key. If the "1.Enable" option is selected, short press the key to choose from "Under-excited", "Grid Manager", or "Over-excited." You will be able to indicate the value of reactive power produced for each of them. If the setting is successful, "OK" will be displayed; otherwise, "Error" will be displayed.

16. Set Power derating

Select "16. Derating P(W)" and long press the key to enter the relative menu, from which you can enable the "Derating" function, i.e. the possibility to set the power produced by the inverter. The display will show "Enter PWD!"; enter the password "0001" by short pressing the key to increase the selected digit. Long press the key to move to the next one and confirm. If the display shows, "Error, try again!" press the key again and enter the password again. When the password entered is correct, you can enter the menu. At this point, short press the key to select the option "1.Enable" or "2.Disable" and confirm the selection by long pressing the key. If the "1.Enable" option is selected, short press the key to select the percentage value (between 0 and 100) of the maximum power that the inverter will produce; if the solar radiation allows a greater amount of energy to be produced, the inverter will carry out the necessary operations to limit the output power to the set value. If the setting is successful, "OK" will be displayed; otherwise, "Error" will be displayed.

17. Set RefluxP

Select “17. Set RefluxP” and long press the key to enter the relative menu, from which you can enable the “Reflux Power” function, i.e. the possibility to set the maximum power fed into the grid. The display will show “Enter PWD!”; enter the password “0001” by short pressing the key to increase the selected digit. Long press the key to move to the next one and confirm. If the display shows, “Error, try again!” press the key again and enter the password again. When the password entered is correct, you can enter the menu. At this point, short press the key to select the option “1.Enable” or “2.Disable” and confirm the selection by long pressing the key. If the “1.Enable” option is selected, short press the key to select the value (expressed in kW, up to two decimal places) of the maximum power that the inverter will feed into the grid. In this way the inverter can feed a maximum power of between 0 kW and the rated power of the inverter into the national grid, based on the solar radiation available and the domestic consumption. If the setting is successful, “OK” will be displayed; otherwise, “Error” will be displayed.

Note: To activate the Reflux Power mode in single-phase inverters, it is necessary to install a CT current sensor, as described in the appropriate procedure.

18. MPPT scan

Select “18. MPPT scan” and long press the key to enter the relative menu.

Shadow scanning, when the component is blocked or abnormal, causing multiple power peaks, by enabling this function, the peak point of maximum power can be tracked.

19. Start Time

Select “19. Set Time” and long press the key to enter the relative menu.

Startup time and recovery reconnection time can be set.

20. Set ElecMeter

Select “20. Set ElectMeter” and long press the key to enter the relative menu.

Enable or disable meter functions.

21. Hard Reflux

Select “21. Hard Reflux” and long press the key to enter the relative menu.

If the power exceeds the anti backflow setting, the machine will be disconnected from the grid.

22. Input Safety

Select “22. Input Safety” and long press the key to enter the relative menu.

After inserting the USB drive, update the safety parameter file inside the USB drive.

23. LogicInterface

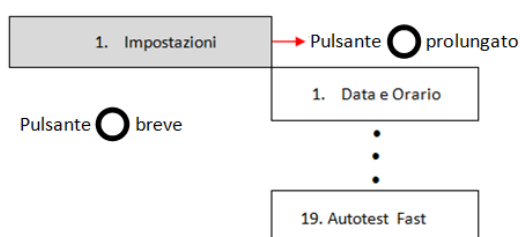
Select “23. LogicInterface” and long press the key to enter the relative menu.

Enable or disable logical interfaces. Please refer to this manual 4.5 RS485, CT, inverter logic interface connection for details.

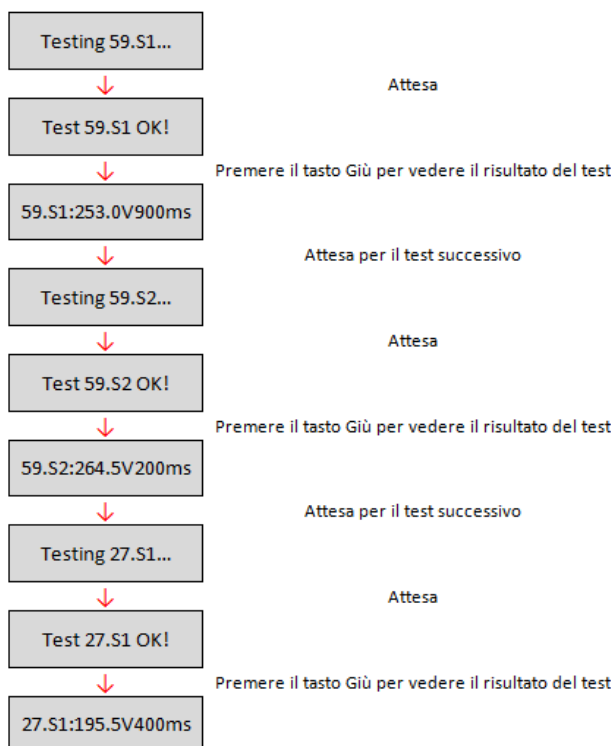
Set the generation ratio.

1. Fast self-test

- 1) During normal operation of the inverter, long press the key to enter the main menu.
- 2) Long press the key again to enter the “Settings” menu.
- 3) Short press the key several times until “19. Fast self-test” is displayed on the screen.



- 4) Long press the key to start the self-test.
- 5) The self-test will now start automatically; once completed, short press the key to display the self-test results, as shown in the figure.

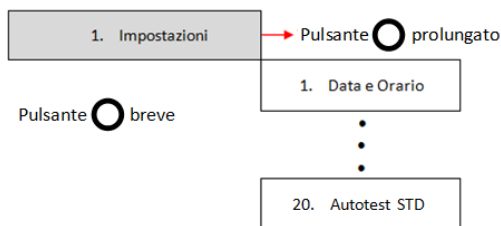


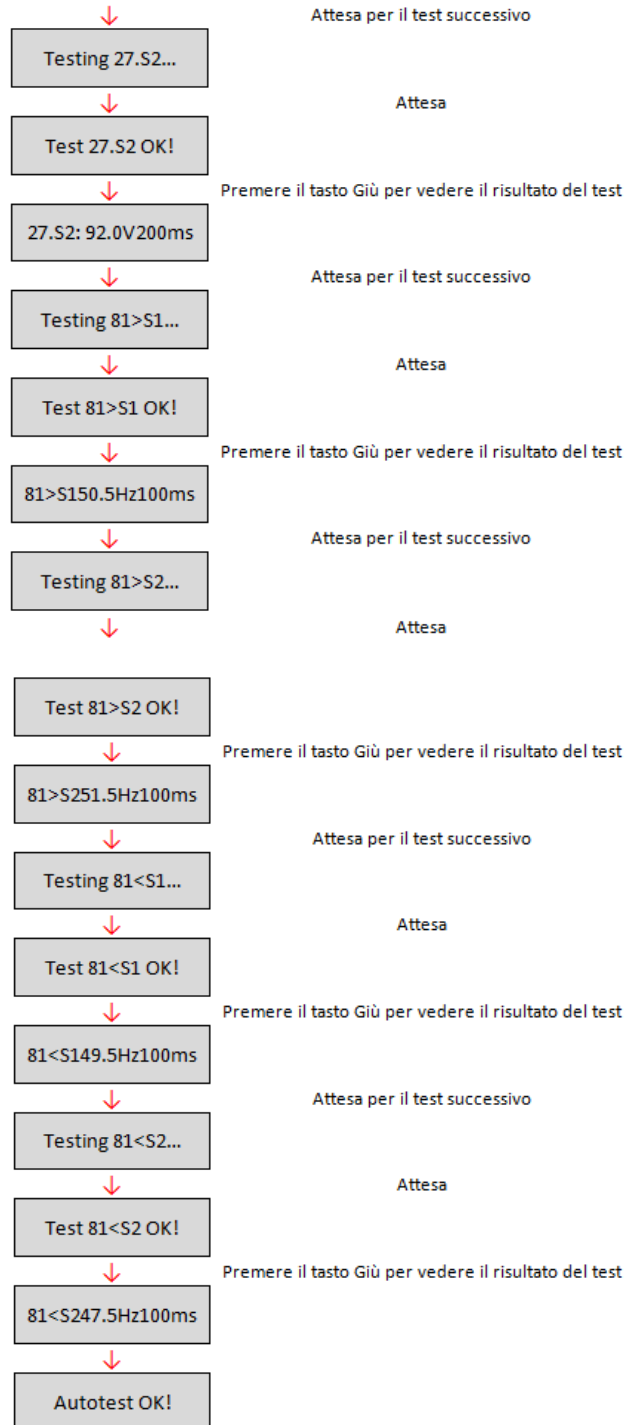


2. Standard Self-test

- 1) During normal operation of the inverter, long press the key to enter the main menu.
- 2) Long press the key again to enter the “Settings” menu.

3) Short press the key several times until “20. STD self-test” is displayed on the screen.





(A) Long press the key to enter the “Event List” menu.

The “Event List” menu is used to display the events recorded by the inverter, both historical and in real time, showing the progressive number of the event, the identification code, the date and time of its occurrence. The user can access this interface from the LCD display to check the details of the alarms and alerts. Errors will be listed according to the date and time they occurred, so the most recent events will be listed first. For more information, refer to the figure below.

Long press the key in the main interface and then short press the key, then enter the menu “2. Event list.” From here you can select the “1. Current Events” menu for the list of current events or “2. Historical Events” for the list of historical events.

2. Event List	
1. Current event	2. Historical event
Fault information	001 ID04 06150825 (Display the event sequence number, event ID number, and event occurrence time)



(B) Long press the key to enter the “System Info” menu.

The “System Info” menu contains the following submenus:

SystemInfo	Long press the button	
	1. Inverter Type	8. Power Factor
	2. Serial Number	9. Reflux Power
	3. Soft Version	10. Safety Paras
	4. Hard Version	11. Hard RefluxP
	5. Country	12. MPPT Scan
	6. Modbus Address	13. Service Code
	7. Input Mode	

- **Inverter type**

From the “System Info” menu, short press the key to move it, and hold it down for a few seconds to enter the menu “1. Inverter type.” Here you can see the power of the inverter model

- **Serial number**

From the “System Info” menu, short press the key to move it, and hold it down for a few seconds to enter the menu “2. Serial number.” Here you can see the serial number of the inverter.

- **SW version**

From the “System Info” menu, short press the key to move it, and hold it down for a few seconds to enter the menu “3. SW version.” Here you can see the software version.

- **HW version**

From the “System Info” menu, short press the key to move it, and hold it down for a few seconds to enter the menu “4. HW version.” Here you can see the hardware version.

- **Country**

From the “System Info” menu, short press the key to move it, and hold it down for a few seconds to enter the menu “5. Country.” Here you can see the country code that has been set.

- **Modbus Address**

From the “System Info” menu, short press the key to move it, and hold it down for a few seconds to enter the menu “6. Modbus Address.” Here you can see the modbus address that has been set.



- **Input Mode**

From the “System Info” menu, short press the key to move it, and hold it down for a few seconds to enter the menu “7. Input Mode.” Here you can see the input mode that has been set.

- **Power factor**

From the “System Info” menu, short press the key to move it, and hold it down for a few seconds to enter the menu “8. Power factor.” Here you can see the value of the power factor.

- **Reflux Power**

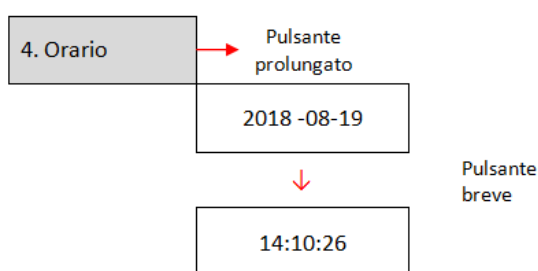
From the “System Info” menu, short press the key to move it, and hold it down for a few seconds to enter the menu “9. Reflux power.” Here you can see the value of the set value of the power fed into the grid.

- **Service Code**

From the “System Info” menu, short press the key to move it, and hold it down for a few seconds to enter the menu “13. Service Code.” Here you can see the currently installed firmware version.

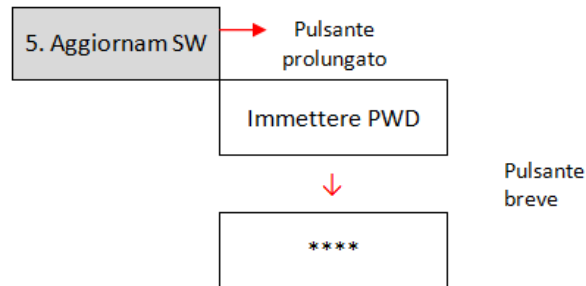
(C) Long press the key to enter the “Date and time” menu.

Long press the key in the main interface and then short press to enter the submenu “4. Date and Time”, then press the key again to display the current date and time set on the inverter.



(D) Long press the key to enter the “Update Software” menu.

Long press the key in the main interface and then short press to enter the submenu “5. Software Update”, then use the key again to access it. The display will show “Enter PWD!”; short press the key to increase the selected digit, and long press the key to go to the next one and confirm. If the display shows, “Error, try again!” press the key again and enter the password again. When the password has been entered correctly, you can enter the menu and start updating the firmware.



Note: You can check the firmware version currently installed on the inverter from the “Service Code” submenu found in the “System Info” menu.

IMPORTANT: Do not update the firmware unless you have first inserted the USB device into the appropriate port, or if the appropriate update files are not found in the USB device. Always make sure that the correct update files are loaded on the USB device and that the device is correctly inserted in the appropriate port.

Note: the USB device is not supplied with the inverter and must be procured by the installer or customer.

The complete and detailed procedure for updating the firmware is described below.

Update requirements

USB device (stick) 8GB

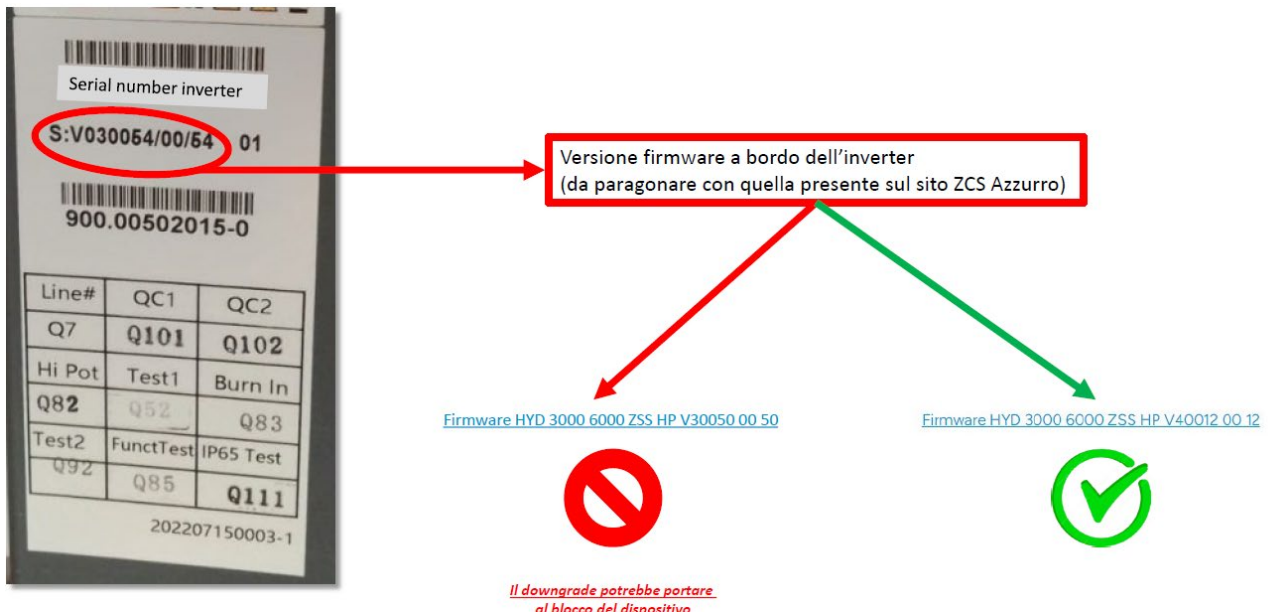
PC with USB port



Firmware update procedure

On first installation, all Zucchetti hybrid inverters must be updated to the latest firmware version found in the www.zcsazzurro.com website, unless the inverter is already updated to the version on the website or to a later version (see example image below).

Do not update the inverter if its firmware version is the same or higher than the one found in the ZCS Azzurro website



ATTENTION!!! Downgrading the firmware version of the inverter could lead to a malfunction.

1. Switch the DC and AC switches off, and then remove the communication cover. If an RS-485 line has been connected, ensure that the nut is loosened. Ensure that the communication line is not energised. Remove the cover to prevent the connected communications connector from becoming loose.
2. Remove the central cover at the bottom of the inverter by unscrewing the two star screws, making sure to have first loosened the four cable glands.

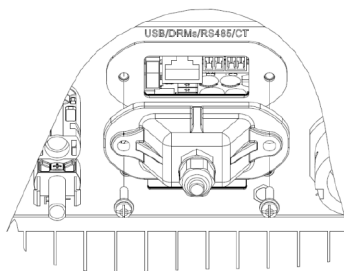


Figure 39 – Removing the central cover

3. Insert the USB device in the appropriate port of the PC;
4. Download the firmware of your inverter from the products section (storage inverters) of the www.zcsazzurro.com website, selecting the inverter model you own;
5. Open the drive and create a new folder with the name *firmware*, making sure to match the lowercase and uppercase letters as indicated, and checking that there are no spaces. Now copy the files provided by ZCS to the *firmware* folder.
6. Extract the USB device from the PC using the “safely remove hardware” process.
7. Insert the USB device in the appropriate port of the inverter.
8. Only supply DC power to the inverter through the appropriate switch and wait a few seconds for the display to come on.
9. Long press the key from the display to enter menu, go to SOFTWARE UPDATE by short pressing the key. Enter the password *0715* and press “OK” again to start the update.
10. The update process will take about 3 minutes and will run automatically. The following indications will be followed:
 - DSP1 Update
 - DSP2 Update
 - ARM Update
11. Check that the inverter completes the update correctly and that “ZCS INNOVATION” appears on the display; the inverter will then start normally. If the update was not successful, one of the following messages will appear on the display: “Commun Err”, “UPDATE DSP1 FAIL” or “UPDATE DSP2 FAIL”; in this case, switch off the inverter, wait one minute and then restart the procedure from step 4.
12. Once the update has been completed successfully, it is necessary to change the country code: enter the “Settings” menu by long pressing the key, then short press the key to scroll down to the “Set Country” item and enter the country code.
13. Note: if the inverter has been running for more than 24 hours, this function must first be enabled from the “Enable Country” menu, which corresponds to item 6 of the “Settings” menu. Enter the password *0001*.
14. Switch off the inverter via the disconnecting switch on the DC line.
15. Restart the inverter by supplying DC power and enter the “set country” menu again. Set the country

code according to the appropriate grid standard (e.g. for Italy: CEI-021 INT, CEI-021 EXT, CEI-016).

16. Switch off the system and restart it after waiting a few minutes, as indicated in step 12.
17. The update procedure has now been completed, and the inverter can now be connected to the AC line by connecting it to the grid; The new firmware version can be checked from the “Service Code” submenu located inside the “System Info” menu.

8. Troubleshooting and maintenance

8.1. Troubleshooting

This section contains information and procedures pertaining to the remedying of potential problems with the inverter.

As the content of this chapter involves software version updates, the differences may exist among different versions of the software. If you have any questions, please contact the Zucchetti Centro Sistemi S.p.a. technical team.

If you have any problems with the inverter, please follow these steps.

- Check the warning messages and error codes on the information panel of the inverter. Record them before carrying out any further operation.
- If the inverter does not display any errors, perform the following checks:
 - Is the inverter located in a clean, dry and properly ventilated place?
 - Is the DC switch closed?
 - Are the cables correctly sized and as short as possible?
 - Are the input/output connections and the cables in good condition?
 - Are the configuration settings correct for the type of installation?
 - Are the display and flat cable correctly connected and not damaged?


Follow the steps below to display the recorded alarms:

Long press the key to enter the main menu from the standard interface. Select “Event List” in the menu screen, then long press the key to access the list of alarms and errors.

Earth fault alarm

This inverter is compliant with IEC 62109-2 Clause 13.9 for earth fault protection.

If an earth fault alarm occurs, the error is displayed on the LCD screen, the red light illuminates and the error can be found in the error history log.

	<p>In the case of devices equipped with a stick logger, the alarm information can be viewed on the monitoring portal.</p>
Note	

Event list

The error codes and troubleshooting methods of the inverter are detailed in the following table.

Code	Name	Description	Solution
ID001	GridOVP	The grid voltage is too high	<p>If the alarm occurs occasionally, the possible cause is that the electric grid is abnormal occasionally. Inverter will automatically return to normal operating status when the electric grid's back to normal.</p>
ID002	GridUVP	The grid voltage is too low	
ID003	GridOFP	The grid frequency is too high	
ID004	GridUFP	The grid frequency is too low	<p>If the alarm occurs frequently, check whether the grid voltage/frequency is within the acceptable range. If yes, please check the AC circuit breaker and AC wiring of the inverter.</p> <p>If the grid voltage/frequency is NOT within the acceptable range and AC wiring is correct, but the alarm occurs repeatedly, contact technical support to change the grid over-voltage, under-voltage, over-frequency, under-frequency protection points after obtaining approval from the local electrical grid operator.</p>
ID005	PVUVP	The input voltage is too low	<p>Check whether too few PV modules are series connected in a PV string, thus the voltage (V_{mp}) of the PV string is lower than the minimum operating voltage of inverter. If yes, adjust the number of series connected PV modules to increase the voltage of the PV string to fit the input voltage range of inverter. inverter automatically returns to normal operating status after correct</p>




Code	Name	Description	Solution
			adjustments.
ID06	Vlvrtlow	LVRT function is faulty	Check whether the grid voltage fluctuates greatly.
ID07	Vovrthigh	OVRT function is faulty	
ID09	PVOVP	The input voltage is too high	Check whether too many PV modules are series connected in a PV string, thus the voltage (Voc) of the PV string is higher than the maximum input voltage of inverter. If yes, adjust the number of series connected PV modules to decrease the voltage of the PV string to fit the input voltage range of inverter. inverter automatically returns to normal operating status after correct adjustments.
ID10	Ipv Unbalance	Input current is not balanced	Check the input mode (parallel mode/ independent mode) setting of inverter according to Section 6.3 (C) 6.Input Mode of this user manual, If it's incorrect, change it according to Section 6.3 (A) 10.Set Input mode of this manual.
ID11	Pv Config Fault	Incorrect input mode	
ID12	GFCI Fault	GFCI Fault	If the fault occurs occasionally, the possible cause is that the external circuits are abnormal occasionally. inverter automatically returns to normal operating status after the fault is rectified. If the fault occurs frequently and lasts a long time, check whether the insulation resistance between the PV array and earth (ground) is too low, then check the insulation conditions of PV cable.
ID14	HwBoost OCP	The input current is too high , and has happen hardware protection	Check whether the input current is higher than the maximum input current of inverters, then check the input wiring, if both are correct, please contact technical support.
ID15	HwAc OCP	The grid current is too high , and has happen hardware protection	ID15-ID24 are internal faults of inverter, turn OFF the “DC switch”, wait for 5 minutes, then turn ON the “DC switch”. Check whether the fault is rectified. Ifno, please contact technical support.
ID16	AcRms OCP	The grid current is too high	
ID17	HwAD Fault		
ID18	IGrid	The grid current	

Code	Name	Description	Solution
		sampling error	
ID19	HwAD FaultDCI	The DCI sampling error	
ID20	HwAD Fault		
ID21	VGrid	The grid voltage sampling error	
ID22	GFCI Device		
ID23	Fault	The GFCI sampling error	
ID24	MChip_Fault	The master chip fault	
ID25	Bus UVP	The bus voltage Is too low	If the PV array configuration is correct (no ID05 fault) , the possible cause is that the solar irradiance is too low. inverter automatically returns to normal operating status after the solar irradiance returns to normal level.
ID26	Bus OVP	The bus voltage Is too high	ID26-ID27 are internal faults of inverter, turn OFF the “DC switch”, wait for 5 minutes, then turn ON the “DC switch”. Check whether the fault is rectified. If no, please contact technical support.
ID27	VbusUnbalance	The bus voltage is not balanced	
ID28	Dci OCP	The Dci is too high	Check the input mode (parallel mode/ independent mode) setting of inverter according to Section 6.3 (C) 6.Input Mode of this user manual, If it's incorrect, change it according to Section 6.3 (A)
ID29	SwOCP Instant	The grid current is too high	Internal faults of inverter, turn OFF the “DC switch”, wait for 5 minutes, then turn ON the “DC switch”. Check whether the fault is rectified. If no, please contact technical support.
ID30	SwB OCP Instant	The input current is too high	Check whether the input current is higher than the maximum input current of inverters, then check the input wiring, if both are correct, please contact technical support.
ID33	GridPhase	The Grid Phase happen Mutation	The phase of the grid voltage has changed
ID53	Spi Comm Lose	The spi communication between the master DSP and slave DSP is fault	

Code	Name	Description	Solution
ID54	Sci Comm Lose	The Sci communication	
ID55	Relay Test Fail	The relays fault	
ID56	Pv Iso Fault	The insulation resistance is too low	Check the insulation resistance between the PV array and earth (ground) , if a short circuit occurs, rectify the fault.
ID58	Over Temp-Boost	The Boost temp is too high	Ensure the installation position and installation method meet the requirements of Section 3.4 of this user manual. Check whether the ambient temperature of the installation position exceeds the upper limit. If yes, improve ventilation to decrease the temperature.
ID59	Over Temp-Env	The environment temp is too high	
ID63	Overload	Too much power is flowing into the grid	When hard counter-current is enabled, when PCC power is greater than hard counter-current power, overload protection is reported
ID64	MeterCommLose	Meter communication error	After receiving the meter communication exception bit sent
ID65	Hw Ac OCP1	The grid current is too high, and has cause unrecoverable hardware fault	ID65-ID70 are internal faults of inverter, turn OFF the “DC switch”, wait for 5 minutes, then turn ON the “DC switch”. Check whether the fault is rectified. If no, please contact technical support.
ID66	Bus OVP1	The bus voltage is too high, and has cause unrecoverable fault	
ID67	Iac Rms Unbalance1	The grid current is unbalanced, and has caused an unrecoverable fault	
ID68	Ipv Unbalance1	The input current is unbalanced, and has caused an unrecoverable fault	
ID69	Vbus Unbalance1	The bus voltage is unbalanced, and has caused the unrecoverable fault	
ID70	OCP Instant1	The grid current is too high, and has caused an unrecoverable fault	
ID74	IPV Instant1	The input current is too	
			ID74-ID77 are internal faults of

Code	Name	Description	Solution
		high, and has caused an unrecoverable fault	inverter, turn OFF the “DC switch”, wait for 5 minutes, then turn ON the “DC switch”. Check whether the fault is rectified. If no, please contact technical support.
ID77	Relay Fail1	Relay has happen permanent fault	
ID81	Over Temp Derating	The inverter has been derated because the temperature is too high	Ensure the installation position and installation method meet the requirements of Section 3.4 of this user manual. Check whether the ambient temperature of the installation position exceeds the upper limit. If yes, improve ventilation to decrease the temperature.
ID82	Over Freq Derating	The inverter has been derated because the grid frequency is too high	Inverter automatically reduce the output power when the frequency of electrical grid is too high. Please make sure the grid frequency is within the acceptable range.
ID83	Remote Derating	The inverter has been derated by the Remote control	Inverter records ID83 in case of remote power derating operation. Check the wiring of remote input and output control signal port on the communication board according to Section 4.5 of this user manual.
ID85	Under Frequency Derating	The inverter is derated because the grid frequency is too low	Inverter automatically reduce the output power when the frequency of electrical grid is too low. Please make sure the grid frequency is within the acceptable range.
ID93	SPD Alarm	The lightning protection tripped	Please check if the machine is damaged and contact the technician for help.
ID94	SW version Fault	The software in the control board and the communication board is not consistent	Contact technical support to upgrade software.
ID95	Comm EEPROM Fault	The communication board EEPROM is faulty	ID95~ID96 are internal faults of inverter, turn OFF the “DC switch”, wait for 5 minutes, then turn ON the “DC switch”. Check whether the fault is rectified. If no, please contact technical support.
ID96	RTC Fault	RTC clock chip is faulty	
ID97	Invalid Country	The country is invalid	Check the country setting according to Section 6.3 (C) 5. Country of this user manual, If it's incorrect, change it

Code	Name	Description	Solution
			according to Section 6.3 (A) 4. Set Country Code of this manual.
ID98	SD fault	The SD card is faulty	Please replace the SD card.

	<p>If the handling methods recommended in the "Solution" column fail to help you, please contact Zucchetti Centro Sistemi S.p.a.</p>
Note	



8.2. Maintenance

Inverters do not generally require daily or routine maintenance. Before carrying out cleaning, ensure that the DC switch and AC circuit breaker between the inverter and power grid have been switched off. Wait at least 5 minutes before carrying out cleaning.

Cleaning the inverter

Clean the inverter using an air blower and a dry, soft cloth or a soft bristle brush. Do NOT clean the inverter with water, corrosive chemicals, cleaning agents etc.

Cleaning the heatsink

In order to help guarantee the correct long-term operation of the inverter, make sure that there is sufficient space for ventilation around the heat sink. Check the heat sink for blockages (dust, snow etc.) and remove them if present. Please clean the heat sink using an air blower and a dry, soft cloth or a soft bristle brush. Do NOT clean the heat sink with water, corrosive chemicals, cleaning agents etc.

9. Uninstalling

9.1. Uninstallation steps

- Disconnect the inverter from the AC grid.
- Switch off the DC switch.
- Wait 5 minutes.
- Remove the DC connectors.
- Remove the AC terminals.
- Unscrew the fixing bolt of the bracket and remove the inverter from the wall.

9.2. Packaging

If possible, pack the product in its original packaging.

9.3. Storage

Store the inverter in a dry place where the ambient temperature is between -25 and +60°C.

9.4. Disposal

Zucchetti Centro Sistemi S.p.a. is not liable for the disposal of the equipment, or parts thereof, that does not take place according to the regulations and standards in force in the country of installation.



The symbol of the crossed-out wheeled bin indicates that the equipment, at the end of its useful life, must be disposed of separately from household waste.

This product must be handed over to the waste collection point in your local community for recycling.

For more information, please contact the waste collection authority in your country.

Inappropriate waste disposal could have negative effects on the environment and on human health due to potentially hazardous substances.

With your cooperation in the correct disposal of this product, you contribute to the reuse, recycling and recovery of the product, and to the protection of our environment.

10. Technical specifications













TECHNICAL DATA	1PH 1100TL2-V3	1PH 1600TL2-V3	1PH 2200TL2-V3	1PH 2700TL2-V3	1PH 3000TL2-V3	1PH 3300TL2-V3	1PH 4000TL2-V3	1PH 5000TL2-V3
DC Input data								
Typical DC power*	1210W	1760W	2420W	2970W	3300W	3630W	4400W	5500W
No. of MPPTs / No. of strings per MPPT					1/1			
Maximum DC input voltage					550V			
Start-up voltage					70V			
Nominal DC input voltage					360V			
MPPT DC voltage range					50V-550V			
DC voltage range at full load	110V-450V	150V-450V	200V-450V	250V-500V	275V-500V	300V-500V	300V-500V	300V-550V
Maximum input current for each MPPT					20A			
Maximum absolute current for each MPPT					25A			
AC Output data								
Rated AC power	1100W	1600W	2200W	2700W	3000W	3300W	4000W	5000W
Maximum AC power	1100VA	1600VA	2200VA	2700VA	3000VA	3300VA	4000VA	5000VA
Maximum AC current	5.3A	7.7A	10.6A	13A	14.5A	16A	19.3A	24.1A
Connection type/Rated grid voltage	Single-phase L/N/PE / 220V,230V,240V							
Grid voltage range	180V~276V (according to the local grid standards)							
Rated grid frequency	50Hz/60Hz							
Grid frequency range	45Hz~55Hz / 54Hz~66Hz (according to the local grid standards)							
Total harmonic distortion	<3%							
Power factor	1 (programmable +/-0.8)							
Active power adjustment range (settable)	0~100%							
Grid feed-in limit	Feed adjustable from zero to nominal power value**							
Efficiency								
Maximum efficiency	97.2%							
Weighted efficiency (EURO)	96.8%							
MPPT efficiency	>99.9%							
Consumption at night	<1W							
Protections								
Internal interface protection	Yes							
Safety protections	Anti-islanding, RCMU, Ground Fault Monitoring							
Reverse polarity protection DC	Yes							
DC circuit breaker	Integrated							
Overheating protection	Yes							
Overvoltage category/Protection class	Overvoltage Category III / Protection class I							
Integrated dischargers	AC/DC MOV: Type 3 standard							
Standard								
EMC	EN 61000-6-1/3, EN 61000-3-2/3							
Safety standard	IEC 62116, IEC 61727, IEC 61683, IEC 60068-1/2/14/30, IEC 62109-1/2							
Grid connection standard	Connection certificates and standards available at www.zcsazzurro.com							
Communication								
Communication interfaces	Wi-Fi/4G/Ethernet (optional), RS485 (proprietary protocol), USB							
Additional inputs or connections	Input for current sensor connection							
General data								
Allowable ambient temperature range	-30°C...+60°C (power limit above 45°C)							
Topology	Transformerless							
Environmental protection class	IP65							
Allowable relative humidity range	0%...95% non-condensing							
Maximum operating altitude	4000m (power limit above 2000m)							
Noise level	< 25dB @ 1mt							
Weight					7 kg			
Weight					7.3 kg			
Cooling	Natural convection							
Dimensions (H x L x D)					321mmx260.5mmx131.5mm			
Dimensions (H x L x D)					321mmx260.5mmx131.5mm			
Data monitoring	LCD Display + APP							
Warranty	5 or 10 years (NB: the extended warranty can be obtained by registering on the EXTENDED WARRANTY section of the zcsazzurro.com website)							

* The typical DC power does not represent a maximum applicable power limit. The online configurator available at www.zcsazzurro.com will provide any applicable configurations.

** Possible by connecting a current sensor (ZST-ACC-TA) or using a specific meter



11. Monitoring systems

ZCS monitoring				
Product code	Product photo	APP monitoring	Portal monitoring	Possibility to send commands and to update the inverter remotely in case of technical support
ZSM-WIFI				
ZSM-ETH				
ZSM-4G				

11.1. External Wi-Fi adapter

11.1.1. Installation

Unlike the internal Wi-Fi card, the external adapter must be installed for all compatible inverters. However, the procedure is quicker and easier as there is no need to open the front cover of the inverter.

In order to monitor the inverter, the RS485 communication address must be set to 01 directly from the display.

Installation tools:

- Cross screwdriver
- External Wi-Fi adapter

- 1) Switch off the inverter following the procedure described in this manual.
- 2) Remove the cover for accessing the Wi-Fi connector on the bottom of the inverter by unscrewing the two cross-head screws (a), or by unscrewing the cover (b), as shown in the figure.

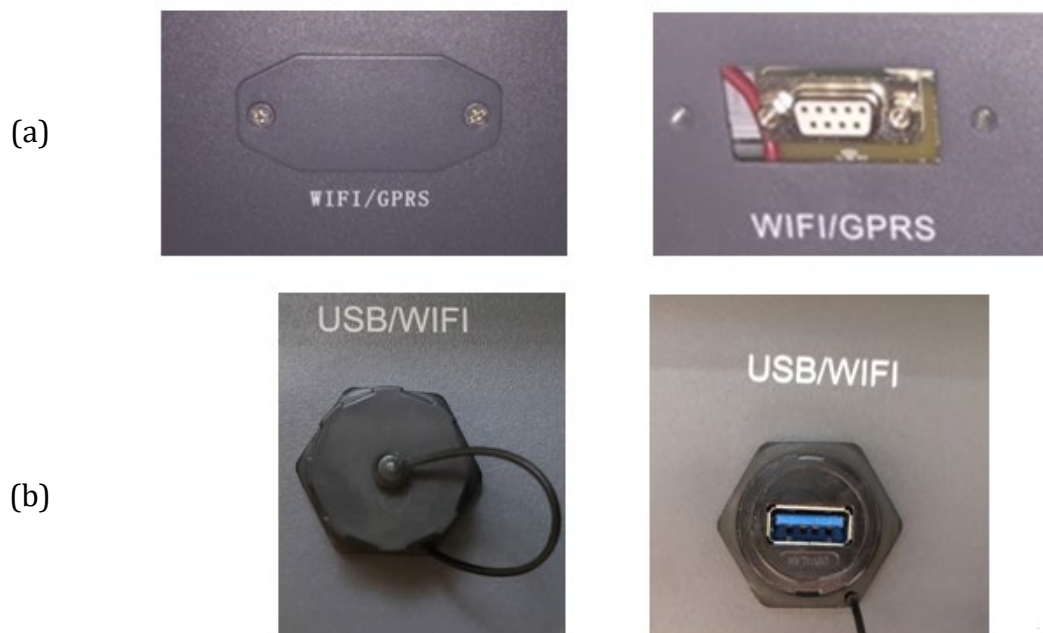


Figure 40 – Port for external Wi-Fi adapter

- 3) Connect the Wi-Fi adapter to the appropriate port, making sure to follow the direction of the connection and ensure correct contact between the two parts.

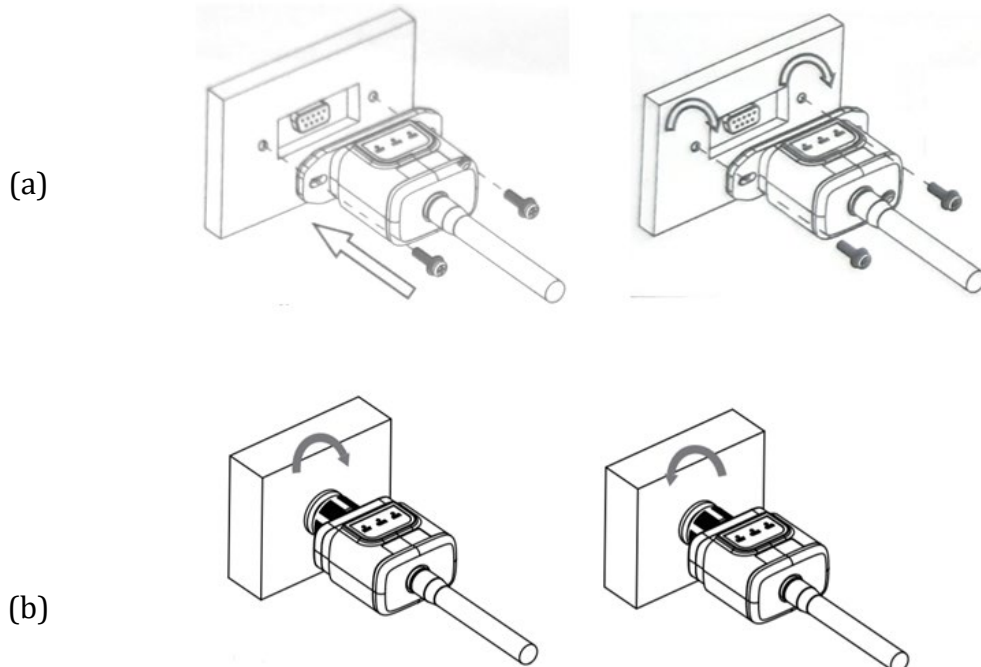


Figure 41 - Inserting and securing the external Wi-Fi adapter

- 4) Switch on the inverter by following the procedure described in the manual.

11.1.2. Configuration

Configuration of the Wi-Fi adapter requires the presence of a Wi-Fi network near the inverter in order to achieve stable transmission of data from the inverter adapter to the Wi-Fi modem.

Tools required for configuration:

- Smartphone, PC or tablet

Go to front of the inverter and search for the Wi-Fi network using a smartphone, PC or tablet, making sure that the signal from the home Wi-Fi network reaches the place where the inverter is installed.

If the Wi-Fi signal is present at the location where the inverter is installed, the configuration procedure can begin.

If the Wi-Fi signal does not reach the inverter, a system must be installed to amplify the signal and bring it to the installation location.

- 1) Activate the search for the Wi-Fi networks on your telephone or PC so that all the networks visible by your device are displayed.



Figure 42 - Search for Wi-Fi networks on iOS smartphone (left) and Android smartphone (right)

Note: Disconnect from any Wi-Fi networks to which you are connected by removing automatic access.



Figure 43 - Disabling automatic reconnection to a network

- 2) Connect to a Wi-Fi network generated by the inverter's Wi-Fi adapter (i.e. AP_*****, where ***** indicates the serial number of the Wi-Fi adapter shown on the label of the device), which operates as an access point.

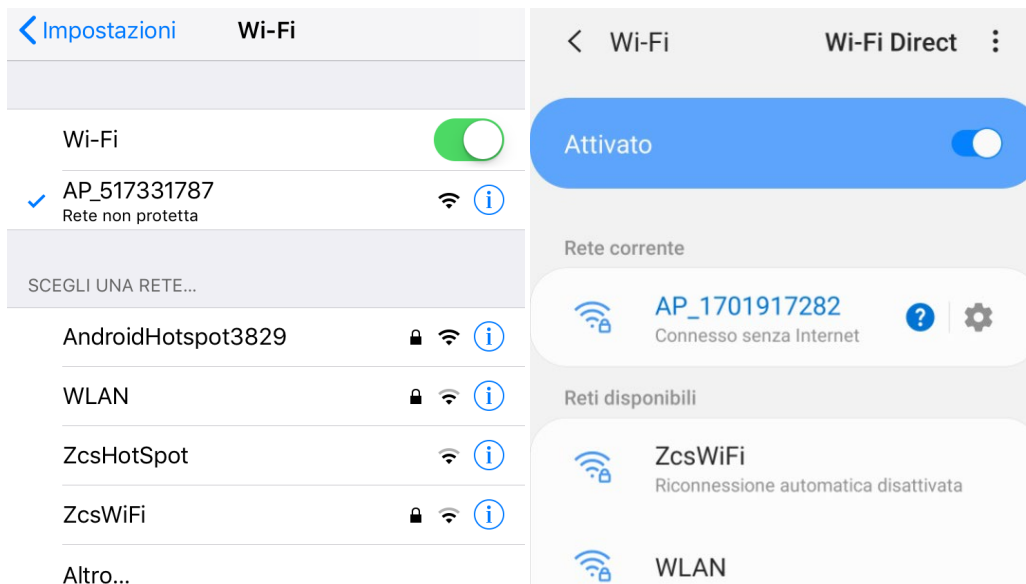


Figure 44 - Connection to Access Point for Wi-Fi adapter on iOS smartphone (left) and Android smartphone (right)

- 3) If you are using a second-generation Wi-Fi adapter, you will be prompted for a password to connect to the inverter's Wi-Fi network. Use the password found on the box or on the Wi-Fi adapter.



Figure 45 - Password of external Wi-Fi adapter

Note: To ensure that the adapter is connected to the PC or smartphone during the configuration procedure, enable automatic reconnection of the AP_***** network.

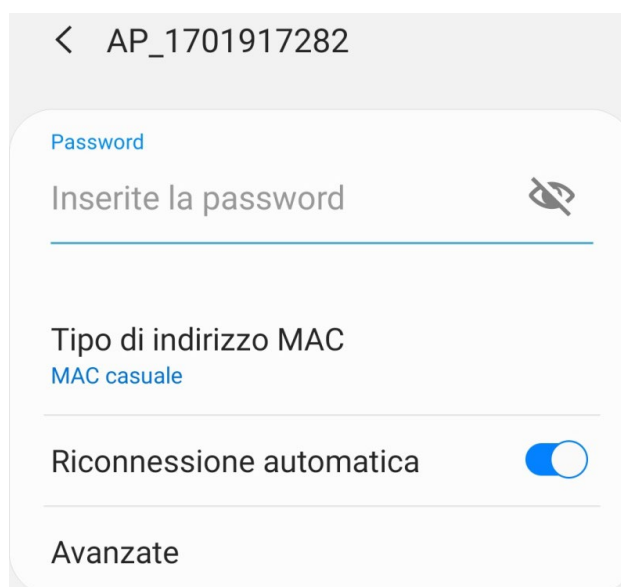


Figure 46 - Password entry prompt

Note: the Access Point is not able to provide internet access; confirm to maintain the Wi-Fi connection, even if the internet is not available



Figure 47 – Screen indicating that the Internet cannot be accessed

- 4) Open a browser (Google Chrome, Safari, Firefox) and enter the IP address 10.10.100.254 in the address bar at the top of the screen.
In the box that appears, enter “admin” as both the Username and Password.

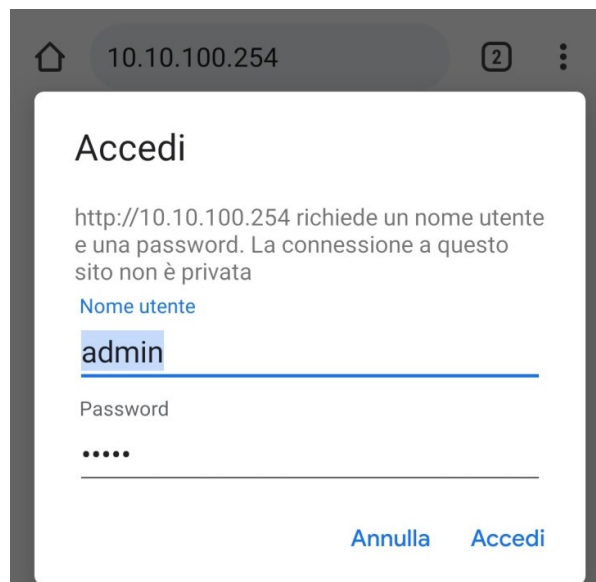
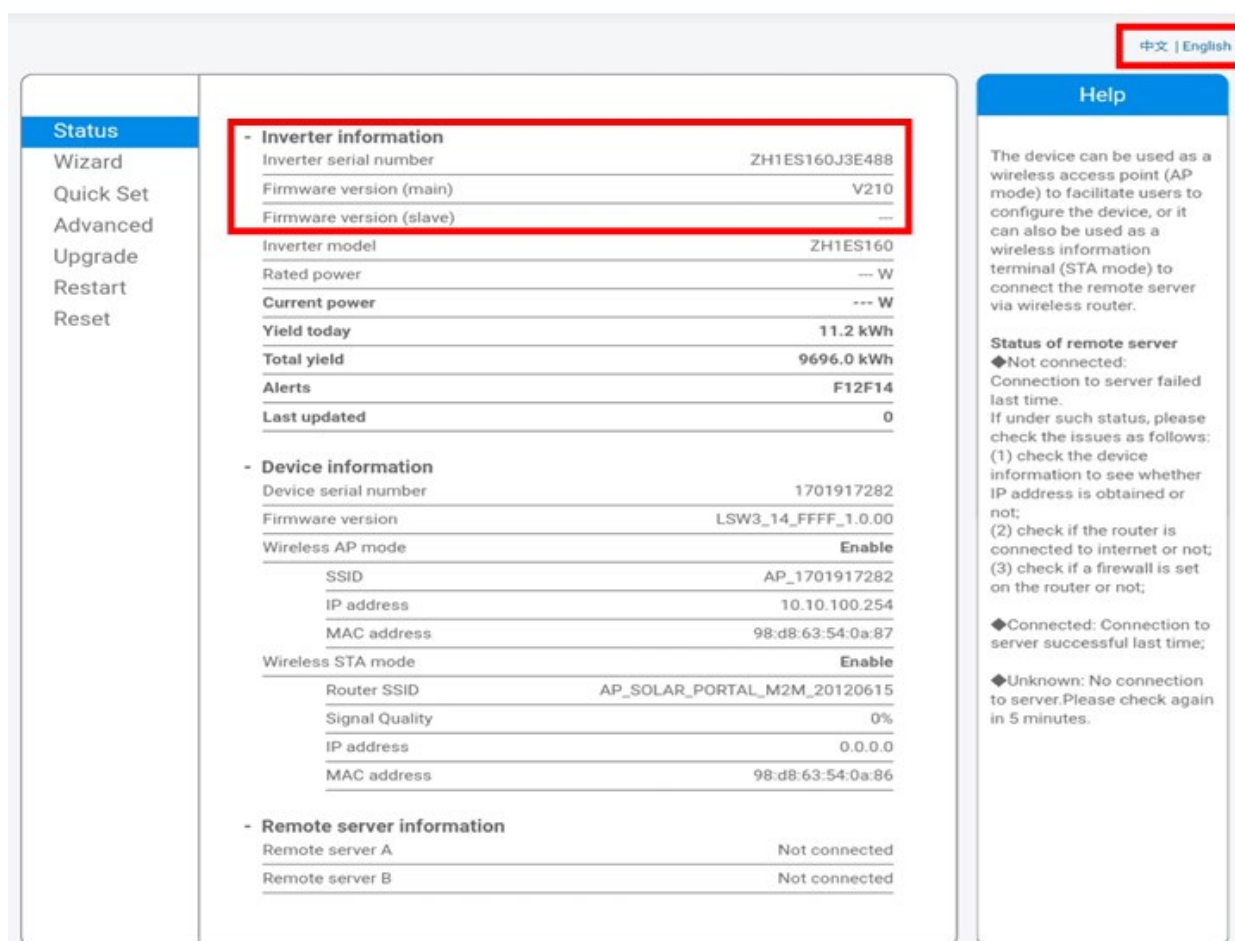


Figure 48 – Screen for accessing the web server to configure the Wi-Fi adapter

- 5) The status screen will open, showing the logger information such as the serial number and firmware version.

Check that the Inverter Information fields are filled in with the inverter information.

The language of the page can be changed using the command in the top right-hand corner.



The screenshot shows the 'Status' screen of a device. At the top right, there is a language selection button with '中文 | English'. On the left, a navigation menu includes 'Status', 'Wizard', 'Quick Set', 'Advanced', 'Upgrade', 'Restart', and 'Reset'. The main content area is divided into three sections: 'Inverter information', 'Device information', and 'Remote server information'. The 'Inverter information' section is highlighted with a red box and contains the following data:

- Inverter information	
Inverter serial number	ZH1ES160J3E488
Firmware version (main)	V210
Firmware version (slave)	---
Inverter model	ZH1ES160
Rated power	--- W
Current power	--- W
Yield today	11.2 kWh
Total yield	9696.0 kWh
Alerts	F12F14
Last updated	0

The 'Device information' section contains the following data:

- Device information	
Device serial number	1701917282
Firmware version	LSW3_14_FFFF_1.0.00
Wireless AP mode	Enable
SSID	AP_1701917282
IP address	10.10.100.254
MAC address	98:d8:63:54:0a:87
Wireless STA mode	Enable
Router SSID	AP_SOLAR_PORTAL_M2M_20120615
Signal Quality	0%
IP address	0.0.0.0
MAC address	98:d8:63:54:0a:86

The 'Remote server information' section contains the following data:

- Remote server information	
Remote server A	Not connected
Remote server B	Not connected

On the right side, there is a 'Help' section with text explaining the device's use as a wireless access point (AP mode) or a wireless information terminal (STA mode) to connect to a remote server via a wireless router. It also includes a 'Status of remote server' section with three states: 'Not connected', 'Connected', and 'Unknown', each with a brief description and troubleshooting steps.

Figure 49 – Status screen

- 6) Click on the Wizard setup button in the left-hand column.
- 7) In the new screen that opens, select the Wi-Fi network to which you want to connect the Wi-Fi adapter, making sure that the Received Signal Strength Indicator (RSSI) is greater than 30%. If the network is not visible, press the Refresh button.

Note: check that the signal strength is greater than 30%, if not, bring the router closer or install a repeater or signal amplifier.
Click Next.

Please select your current wireless network:

Site Survey

SSID	BSSID	RSSI	Channel
<input checked="" type="radio"/> iPhone di Giacomo	EE:25:EF:6C:31:18	100	6
<input type="radio"/> ZcsWiFi	FE:EC:DA:1D:C3:9	86	1
<input type="radio"/> ZcsHotSpot	FC:EC:DA:1D:C3:9	86	1
<input type="radio"/> WLAN	E:EC:DA:1D:C3:9	86	1
<input type="radio"/> ZcsHotSpot	FC:EC:DA:1D:C8:A3	57	11
<input type="radio"/> WLAN	E:EC:DA:1D:C8:A3	57	11
<input type="radio"/> ZcsWiFi	FE:EC:DA:1D:C8:A3	54	11
<input type="radio"/> WLAN	E:EC:DA:1D:C8:8B	45	1
<input type="radio"/> ZcsWiFi	FE:EC:DA:1D:C8:8B	37	1
<input type="radio"/> ZcsHotSpot	FC:EC:DA:1D:C8:8B	35	1

★Note: When RSSI of the selected WiFi network is lower than 15%, the connection may be unstable, please select other available network or shorten the distance between the device and router.

Refresh

Add wireless network manually:

Network name (SSID)
(Note: case sensitive)

Encryption method

Encryption algorithm

Next

1 2 3 4

Figure 50 – Screen for selecting the available wireless network (1)

- 8) Enter the password of the Wi-Fi network (Wi-Fi modem), clicking on Show Password to make sure it is correct; the password should not contain special characters (&, #, %) and spaces.
Note: During this step, the system is not able to ensure that the password entered is the one actually requested by the modem, therefore please make sure you enter the correct password.
Also check that the box below is set to Enable.
Then click “Next” and wait a few seconds for verification.

Please fill in the following information:

Password (8-64 bytes)
(Note: case sensitive)
 Show Password

Obtain an IP address automatically

IP address

Subnet mask

Gateway address

DNS server address

1 2 3 4

Figure 51 – Screen for entering the password of the wireless network (2)

9) Click “Next” again without ticking any of the options relating to the system security.

Enhance Security

You can enhance your system security by choosing the following methods

- Hide AP
- Change the encryption mode for AP
- Change the user name and password for Web server

1 2 3 4

Figure 52 - Screen for setting the security options (3)

10) Click “OK”.

Setting complete!

Click OK, the settings will take effect and the system will restart immediately.

If you leave this interface without clicking OK, the settings will be ineffective.

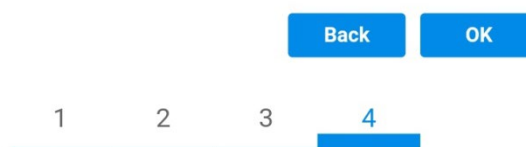


Figure 53 – Final configuration screen (4)

- 11) At this point, if the configuration of the adapter is successful, the last configuration screen will appear, and the telephone or PC will unpair from the inverter’s Wi-Fi network.
- 12) Manually close the web page with the Close key on the PC por remove it from the background of the telephone.



Setting complete! Please close this page manually!

Please login our management portal to monitor and manage your PV system.(Please register an account if you do not have one.)

To re-login the configuration interface, please make sure that your computer or smart phone

Web Ver:1.0.24

Figure 54 - Successful configuration screen

11.1.3. Verification

Wait two minutes after configuring the adapter and then go back to the Wi-Fi network selection screen to verify that the AP_***** network is no longer present. The absence of the Wi-Fi network in the list will confirm the successful configuration of the Wi-Fi adapter.



Figure 55 – Wi-Fi network search on Smartphone (iOS and Android); Access point of the Wi-Fi adapter is no longer visible

If the Wi-Fi network is still present in the list, connect to it again and enter the status page. Check the following information:

- a. Wireless STA mode
 - i. Router SSID > Router name
 - ii. Signal Quality > other than 0%
 - iii. IP address > other than 0.0.0.0
- b. Remote server information
 - i. Remote server A > Connected

Wireless STA mode		Enable
Router SSID	iPhone di Giacomo	
Signal Quality	0%	
IP address	0.0.0.0	
MAC address	98:d8:63:54:0a:86	
- Remote server information		
Remote server A	Not connected	

Figure 56 – Status screen

Status of LEDs present on the adapter

- 1) Initial status:
 - NET (left LED): off
 - COM (central LED): steady on
 - READY (right LED): flashing on



Figure 57 - Initial status of LEDs

2) Final status:

NET (left LED): steady on

COM (central LED): steady on

READY (right LED): flashing on



Figure 58 - Final status of LEDs

If the NET LED does not light up or if the Remote Server A option in the Status page still shows “Not Connected”, the configuration was not successful, i.e. the wrong router password was entered or the device was disconnected during connection.



It is necessary to reset the adapter:

- Press the Reset button for 10 seconds and release
- After a few seconds, the LEDs will turn off and READY will start to flash quickly
- The adapter has now returned to its initial state. At this point, the configuration procedure can be repeated again.

The adapter can only be reset when the inverter is switched on.



Figure 59 – Reset button on the Wi-Fi adapter

11.1.4. Troubleshooting

Status of LEDs present on the adapter

1) Irregular communication with inverter

- NET (left LED): steady on
- COM (central LED): off
- READY (right LED): flashing on



Figure 60 - Irregular communication status between inverter and Wi-Fi

- Check the Modbus address set on the inverter:
Enter the main menu with the ESC key (first key on the left), go to System Info and press ENTER to enter the submenu. Scroll down to the Modbus address parameter and make sure it is set to 01 (and in any case, other than 00).
If the value is not 01, go to “Settings” (basic settings for hybrid inverters) and enter the Modbus Address menu where the 01 value can be set.
- Check that the Wi-Fi adapter is correctly and securely connected to the inverter, making sure to tighten the two cross-head screws provided.
- Check that the Wi-Fi symbol is present in the top right-hand corner of the inverter's display (steady or flashing).



Figure 61 – Icons on the display of LITE single-phase inverters (left) and three-phase or hybrid inverters (right)

- Restart the adapter:
 - Press the reset button for 5 seconds and release
 - After a few seconds, the LEDs will turn off and will start to flash quickly
 - The adapter will now be reset without having lost the configuration with the router

2) Irregular communication with remote server

- NET (left LED): off
- COM (central LED): on
- READY (right LED): flashing on



Figure 62 - Irregular communication status between Wi-Fi and remote server

- Check that the configuration procedure has been carried out correctly and that the correct network password has been entered.
- When searching for the Wi-Fi network using a smartphone or PC, make sure that the Wi-Fi signal is strong enough (a minimum RSSI signal strength of 30% is required during configuration). If necessary, increase it by using a network extender or a router dedicated to inverter monitoring.
- Check that the router has access to the network and that the connection is stable; check that a PC or smartphone can access the Internet
- Check that port 80 of the router is open and enabled to send data

- Reset the adapter as described in the previous section

If, at the end of the previous checks and subsequent configuration, Remote server A is still “Not Connected” or the NET LED is off, there may be a transmission problem at the home network level and, more specifically, that data between the router and server is not being transmitted correctly. In this case, it is advisable to carry out checks at the router level in order to ensure that there are no obstructions on the output of data packets to our server.

To make sure that the problem lies in the home router and to exclude problems with the Wi-Fi adapter, configure the adapter using the Wi-Fi hotspot function on your smartphone as a reference wireless network.

- **Using an Android mobile phone as a modem**

- Check that the 3G/LTE connection is active on your smartphone. Go to the Settings menu of the operating system (the gear icon on the screen with a list of all the apps installed on the phone), select “Other” from the Wireless and networks menu and make sure that the Network type is set to 3G/4G/5G.
- In the Android settings menu, go to Wireless & networks > Other. Select Mobile Hotspot/Tethering, and then enable the Wi-Fi mobile hotspot option; wait a few seconds for the wireless network to be created. To change the name of the wireless network (SSID) or your password, select Configure Wi-Fi hotspot.

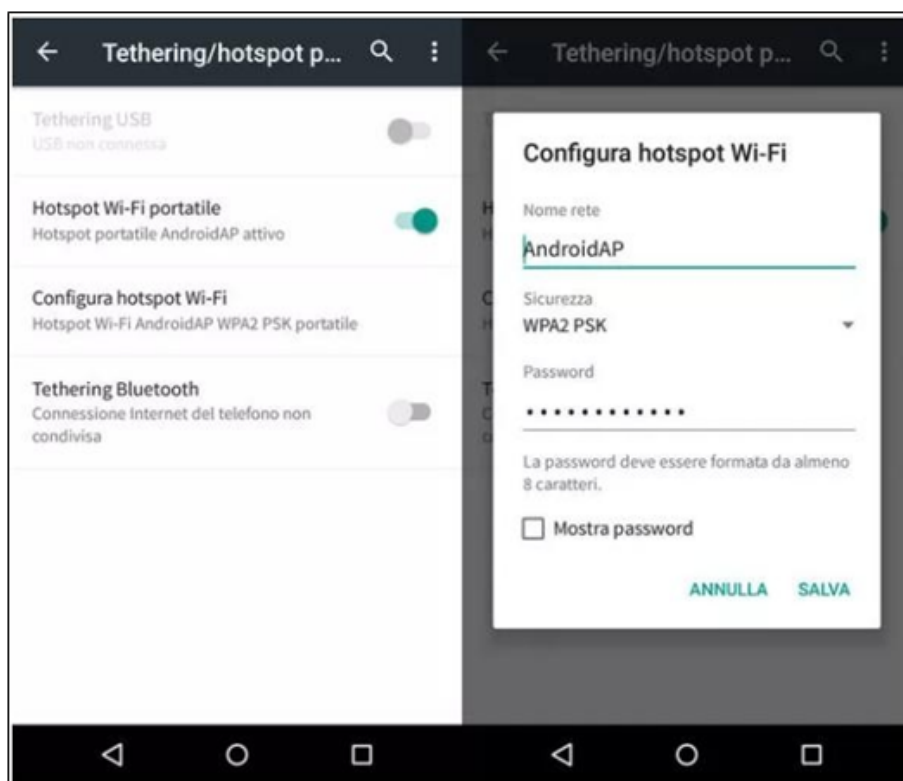


Figure 63 – Configuration of an Android smartphone as a hotspot router



- **Using an iPhone as a modem**

- In order to share the iPhone connection, verify that the 3G/LTE network is active by going to Settings > Mobile Phone, and making sure that the “Voice and data” option is set to 5G, 4G or 3G. To enter the iOS settings menu, click the grey gear icon on the home screen of your phone.
- Go to the Settings menu > Personal Hotspot and turn on the Personal Hotspot option. The hotspot is now enabled. To change the password of the Wi-Fi network, select Wi-Fi password from the personal hotspot menu.

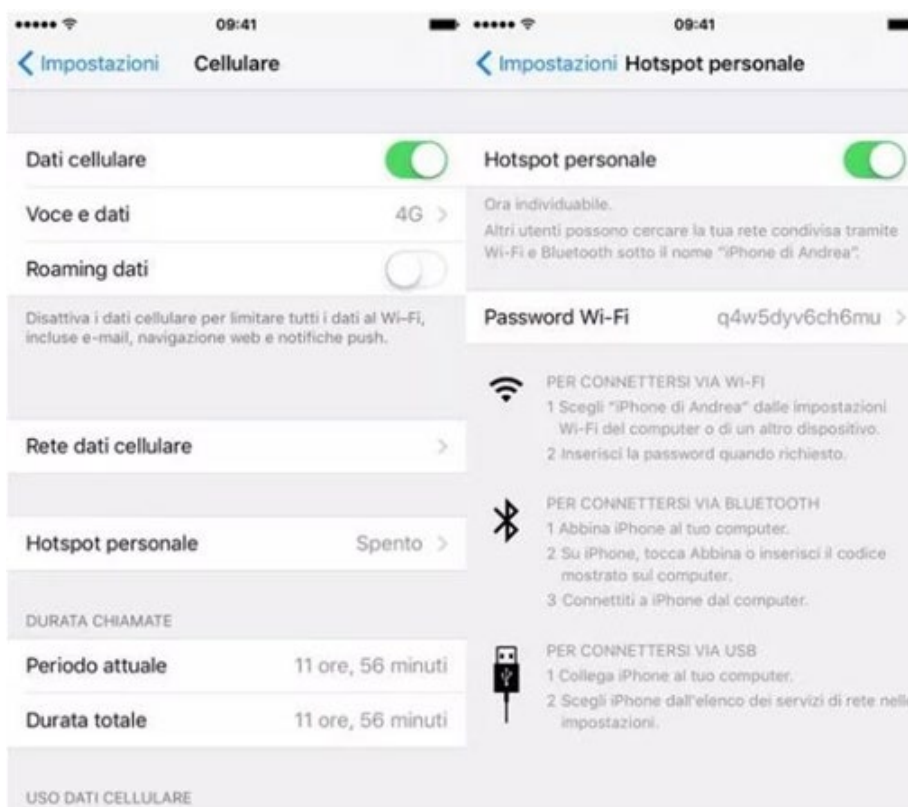


Figure 64 - Configuration of an iOS smartphone as a hotspot router

At this point, it is necessary to re-configure the Wi-Fi adapter using a PC or smartphone other than the one used as a modem.

During this procedure, when asked to select the Wi-Fi network, choose the one activated by the smartphone and then enter the password associated with it (which can be changed from the personal hotspot settings). If at the end of configuration, “Connected” appears next to “Remote Server A”, then the problem is with the home router.

It is therefore advisable to check the brand and model of the home router you are trying to connect to the Wi-Fi adapter; some router brands may have closed communication ports. In this case, contact the customer service of the router’s manufacturer and ask them to open port 80 (direct from the network to external users).

11.2. Ethernet adapter

11.2.1. Installation

Installation must be carried out for all inverters compatible with the adapter. However, the procedure is quicker and easier as there is no need to open the front cover of the inverter. Proper operation of the device requires the presence of a modem correctly connected to the network and in operation in order to achieve stable data transmission from the inverter to the server.

In order to monitor the inverter, the RS485 communication address must be set to 01 directly from the display.

Installation tools:

- Cross screwdriver
 - Ethernet adapter
 - Shielded network (Cat. 5 or Cat. 6) crimped with RJ45 connectors
- 1) Switch off the inverter following the procedure described in this manual.
 - 2) Remove the cover for accessing the Wi-Fi/Eth connector on the bottom of the inverter by unscrewing the two cross-head screws (a), or by unscrewing the cover (b), depending on the inverter model, as shown in the figure.

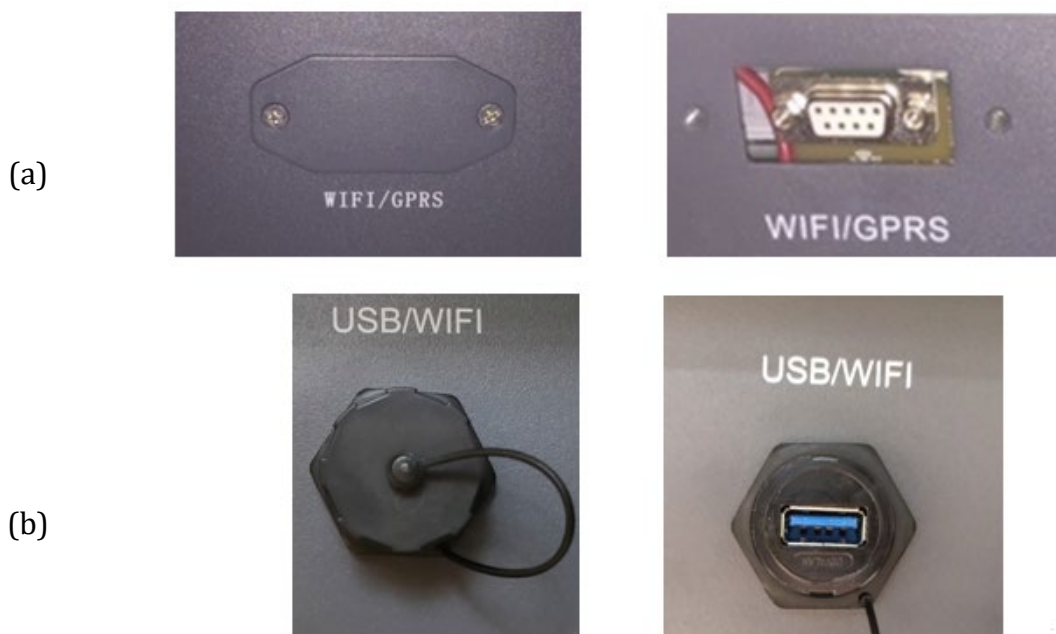


Figure 65 – Port of the Ethernet adapter

- 3) Remove the ring nut and the waterproof cable gland from the adapter to allow the network cable to pass through; then insert the network cable network into the appropriate port on the inside of the adapter and tighten the ring nut and cable gland to ensure a stable connection.

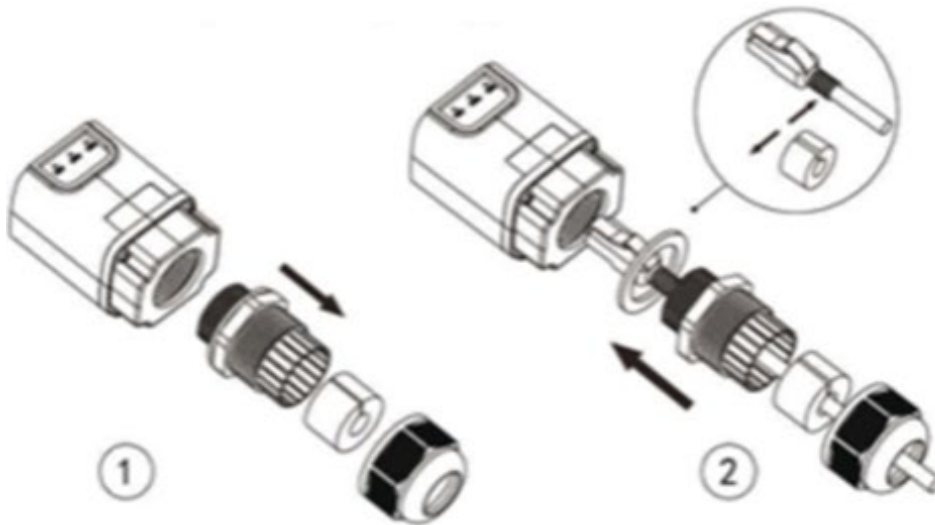


Figure 66 - Inserting the network cable inside the device

- 4) Connect the Ethernet adapter to the appropriate port, making sure to follow the direction of the connection and ensure correct contact between the two parts.

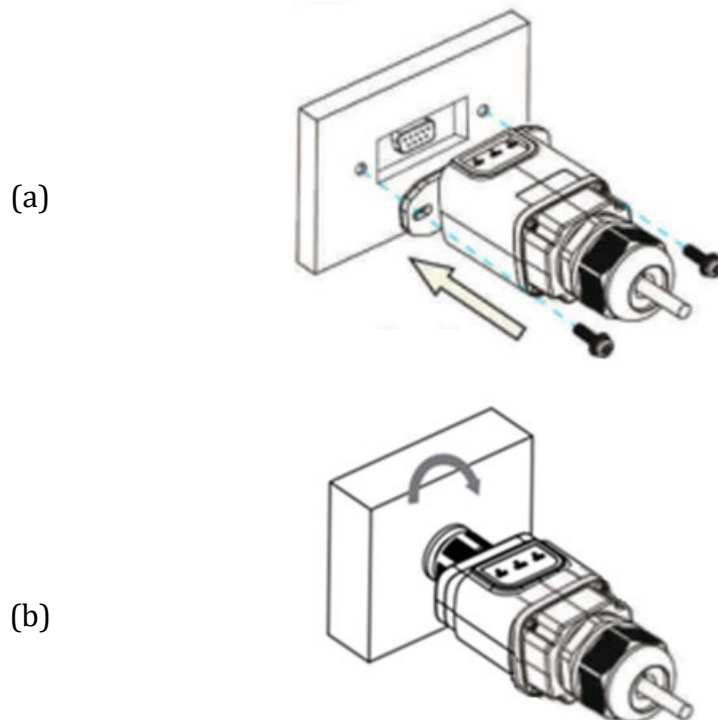


Figure 67 - Inserting and securing the ethernet adapter

- 5) Connect the other end of the network cable to the ETH output (or equivalent) of the modem or a suitable data transmission device.

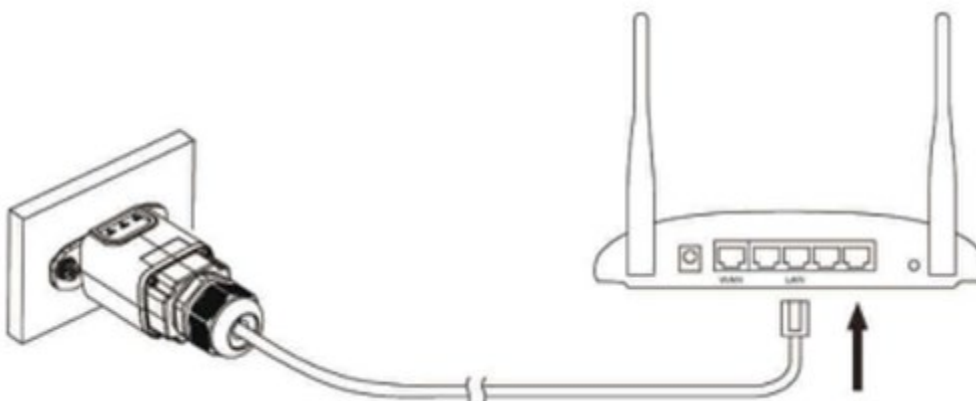


Figure 68 - Connecting the network cable to the modem

- 6) Switch on the inverter by following the procedure described in the manual.
- 7) Unlike Wi-Fi cards, the Ethernet adapter does not need to be configured and starts transmitting data shortly after the inverter is switched on.

11.2.2. Verification

Wait two minutes after installing the adapter, and check the status of the LEDs on the device.

Status of LEDs present on the adapter

- 1) Initial status:
- NET (left LED): off
 - COM (central LED): steady on
 - SER (right LED): flashing on



Figure 69 - Initial status of LEDs

- 2) Final status:
- NET (left LED): steady on
 - COM (central LED): steady on
 - SER (right LED): flashing on



Figure 70 - Final status of LEDs

11.2.3. Troubleshooting

Status of LEDs present on the adapter

- 1) Irregular communication with inverter
- NET (left LED): steady on
 - COM (central LED): off
 - SER (right LED): flashing on



Figure 71 - Irregular communication status between the inverter and adapter

- Check the Modbus address set on the inverter:
 Enter the main menu with the ESC key (first key on the left), go to System Info and press ENTER to enter the submenu. Scroll down to the Modbus address parameter and make sure it is set to 01 (and in any case, other than 00).
 If the value is not 01, go to “Settings” (basic settings for hybrid inverters) and enter the Modbus Address menu where the 01 value can be set.
- Check that the Ethernet adapter is correctly and securely connected to the inverter, making sure to tighten the two cross-head screws provided. Check that the network cable is correctly inserted into the device and modem, and that the RJ45 connector is correctly crimped.

2) Irregular communication with remote server

- NET (left LED): off
- COM (central LED): on
- SER (right LED): flashing on



Figure 72 - Irregular communication status between the adapter and remote server

- Check that the router has access to the network and that the connection is stable; check that a PC can access the Internet

Check that port 80 of the router is open and enabled to send data.

It is advisable to check the brand and model of the home router you are trying to connect to the Ethernet adapter; some router brands may have closed communication ports. In this case, contact the customer service of the router’s manufacturer and ask them to open port 80 (direct from the network to external users).

11.3. 4G adapter

The ZCS 4G adapters are sold with a virtual SIM integrated into the device with data traffic fee included for 10 years, which is adequate for the proper transmission of data to monitor the inverter.

In order to monitor the inverter, the RS485 communication address must be set to 01 directly from the display.

11.3.1. Installation

Installation must be carried out for all inverters compatible with the adapter. However, the procedure is quicker and easier as there is no need to open the front cover of the inverter.

Installation tools:

- Cross screwdriver
- 4G adapter

- 1) Switch off the inverter following the procedure described in this manual.
- 2) Remove the cover for accessing the Wi-Fi/ GPRS connector on the bottom of the inverter by unscrewing the two cross-head screws (a), or by unscrewing the cover (b), depending on the inverter model, as shown in the figure.



Figure 73 – Port of the 4G adapter

- 3) Insert the 4G adapter into the appropriate port, making sure to follow the direction of the connection and ensure correct contact between the two parts. Secure the 4G adapter by tightening the two screws inside the package.

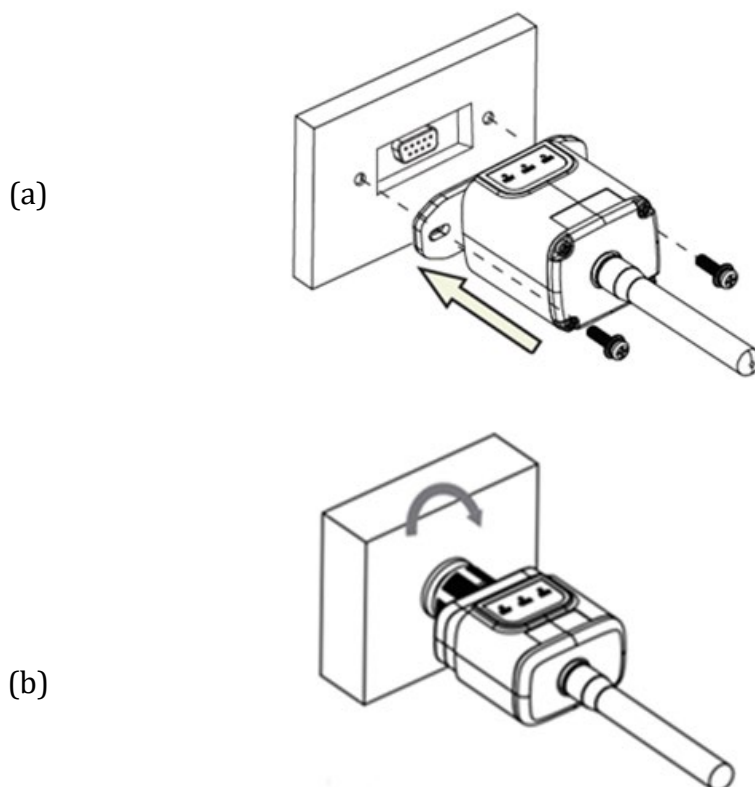


Figure 74 - Inserting and securing the 4G adapter

- 4) Switch on the inverter by following the procedure described in the manual.
- 5) Unlike Wi-Fi cards, the 4G adapter does not need to be configured and starts transmitting data shortly after the inverter is switched on.

11.3.2. Verification

After installing the adapter, within the next 3 minutes check the status of the LEDs on the device to ensure that the device is configured correctly.

Status of LEDs present on the adapter

1) Initial status:

- NET (left LED): off
- COM (central LED): flashing on
- SER (right LED): flashing on



Figure 75 - Initial status of LEDs

2) Registration:

- NET (left LED): flashes rapidly for about 50 seconds; the registration process takes about 30 seconds
- COM (central LED): flashes rapidly 3 times after 50 seconds

3) Final status (approx. 150 seconds after the inverter has started):

- NET (left LED): flashing on (off and on at equal intervals)
- COM (central LED): steady on
- SER (right LED): steady on



Figure 76 - Final status of LEDs

Status of LEDs present on the adapter

1) Irregular communication with inverter

- NET (left LED): on
- COM (central LED): off
- SER (right LED): on



Figure 77- Irregular communication status between inverter and adapter

- Check the Modbus address set on the inverter:
 Enter the main menu with the ESC key (first key on the left), go to System Info and press ENTER to enter the submenu. Scroll down to the Modbus address parameter and make sure it is set to 01 (and in any case, other than 00).

 If the value is not 01, go to “Settings” (basic settings for hybrid inverters) and enter the Modbus Address menu where the 01 value can be set.
- Check that the 4G adapter is correctly and securely connected to the inverter, making sure to tighten the two cross-head screws provided.

2) Irregular communication with remote server:

- NET (left LED): flashing on
- COM (central LED): on
- SER (right LED): flashing on



Figure 78 - Irregular communication status between the adapter and remote server

- Check that the 4G signal is present in the installation location (the adapter uses the Vodafone network for 4G transmission; if this network is not present or the signal is weak, the SIM will use a different network or will limit the data transmission speed). Ensure that the installation location is suitable for 4G signal transmission and that there are no obstacles that could affect data transmission.
- Check the status of the 4G adapter and that there are no external signs of wear or damage.

11.3.3. Local monitoring

The datalogger makes it possible to obtain an additional monitoring system (**local monitoring**), which can be used locally on a web page (therefore, also without an internet connection) and accessed from any device present in the same local network as the datalogger.

11.3.3.1. Requirements for installation of local monitoring

In order to install the local monitoring system on the datalogger, the customer must ensure that:

- The datalogger is connected to the local network and to the internet (the internet connection is only required during installation and configuration of the local monitoring system).
- A static address (to be provided by the customer) with gateway and subnet mask is available for viewing the page locally.

11.3.3.2. Features of local monitoring

After installation and configuration, local monitoring makes it possible to monitor the fundamental parameters of the photovoltaic system, even without an internet connection, from any device connected to the network.

In particular, it is possible to monitor the power and energy of the inverters and the storage systems. It is also possible to view alarms, and other information such as temperature, peak daily power, CO₂ gains and savings.

Below is an example of a local monitoring page.

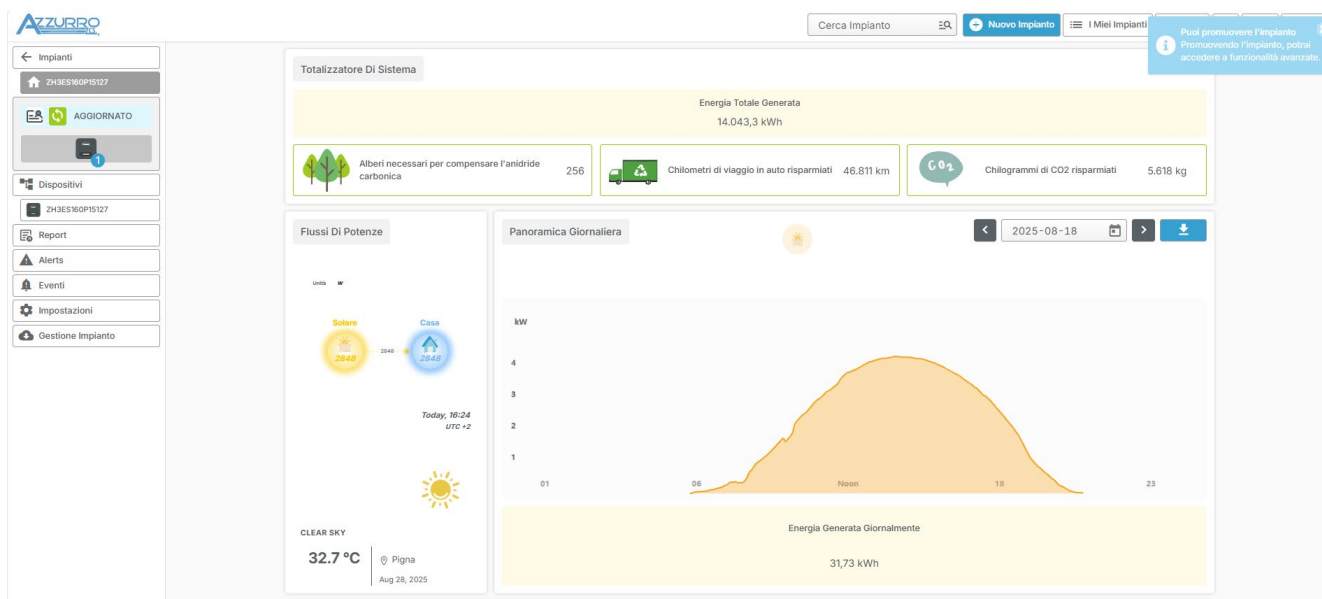


Figure 105: Example of local monitoring page (pure photovoltaic inverter)



Figure 105: Example of local monitoring page (hybrid inverter)

12. Warranty terms and conditions

To view the “Warranty Terms and Conditions” offered by ZCS Azzurro, please refer to the documentation inside the product box and on the website www.zcsazzurro.com.



THE INVERTER THAT LOOKS AT THE FUTURE

zcsazzurro.com



Zucchetti Centro Sistemi S.p.A.
Green Innovation Division
Palazzo dell'Innovazione - Via Lungarno, 167
52028 Terranuova Bracciolini - Arezzo, Italy
zcscompany.com

