



USER'S MANUAL



THREE-PHASE HYBRID STORAGE INVERTERS

3PH HYD 40000-HYD60000-ZSR



ZUCCHETTI
Centro Sistemi



IMPORTANT COMMUNICATION

Inside the box of this product is available the manual in English. Please note that more up-to-date revisions of the supplied manual may be available. Therefore, in order to ensure the correct installation and maintenance procedure it is necessary to verify the manuals, available in all languages, within the documentation or products section of the www.zcsazzurro.com website, the same documentation is also available by scanning the qrcode on the front of the product or directly within the app Azzurro Operators.

Datasheets, technical notes, certifications and warranty terms and conditions are also available on the above platforms.

Hybrid Inverter 3PH HYD30000-HYD60000-ZSR **User Manual**





CONTENT

1	About this manual	5
1.1	Copyright declaration	5
1.2	Presentation of warnings	6
1.3	Presentation of action instructions	7
1.4	Note	7
2	Basic safety information	8
2.1	Safety information	8
2.2	Symbols and signs	12
3	Product features	15
3.1	Product information	15
3.2	Product dimensions	16
3.3	Labelling on the device	17
3.4	Electrical block diagram	17
3.5	Application modes	18
4	Installation	25
4.1	Installation information	25
4.2	Installation procedure	26
4.3	Examination before installation	26
4.4	Connections	29
4.5	Tools	30
4.6	Installation Environment Requirements	31
4.7	Installation location	32
4.8	Unpacking the inverter	35
4.9	Installation of the inverter	36
4.10	Configurations Battery for Inverter	39
5	Electrical connections	41

5.1	Safety instructions	41
5.2	Wiring overview	43
5.3	System Electrical Topology	44
5.4	Meter/CT	46
5.5	Electrical connection	50
5.6	Connecting the PE cables	50
5.7	Connecting the DC cable for the PV modules and battery	52
5.8	Connecting the AC power cables	56
5.9	AC connector installation	58
5.10	Communication interfaces	60
5.11	Feed-in limit function	85
5.12	System monitoring	86
5.13	Installation of the Wi-Fi	87
6	Installation of the ZCB8000-64/80/96kWh System	119
6.1	Cabinet System Instructions	119
6.2	Cabinet System Installation Requirements	120
6.3	Cabinet System Product Overview	122
6.4	Delivery Inspection – Cabinet System	123
6.5	Cabinet System Installation	126
6.6	Lifting and Transport Using a Forklift – Cabinet System	127
6.7	Installation of the Energy Storage System – Cabinet	129
6.8	Installation of the Sunshade Kit – Cabinet System	131
6.9	Installation of the PV Inverter Mounting Bracket (Cabinet System)	131
6.10	Installation of Cable Glands – Energy Storage System (Cabinet System)	132
6.11	Installation of the Grounding Conductor – Energy Storage System (Cabinet System)	133
6.12	Installation of the Air Conditioning Drain Pipe (Cabinet System)	133
6.13	Installation of Connection Cables (Cabinet System)	134
6.14	Power-On	138
7	Commissioning the inverter	139





7.1	Safety test before commissioning	139
7.2	Double Check	139
7.3	Starting the inverter	140
7.4	Initial setup	140
8	Operation of the device	142
8.1	Control panel and display field	142
8.2	Standard display	143
8.3	Energy storage modes	144
8.4	“Firmware update” menu	156
9	Troubleshooting handling	158
9.1	Troubleshooting	158
9.2	Error list	160
9.3	Maintenance	172
10	Technical Data	173
11	Uninstalling	177
11.1	Uninstallation steps	177
11.2	Packaging	177
11.3	Storage	177
11.4	Disposal	177
12	Warranty terms and conditions	179

General instructions

This manual contains important safety instructions that must be followed during installation and maintenance of the equipment.

Please keep these instructions!

This manual must be considered an integral part of the equipment, and must be available at all times to everyone who interacts with the equipment. The manual must always accompany the equipment, even when it is transferred to another user or plant.

Copyright statement

Copyright of this manual belongs to Zucchetti Centro Sistemi S.p.A. No part of this manual (including the software, etc.) may be copied, reproduced or distributed in any form or by any means without the permission of Zucchetti Centro Sistemi S.p.A. All rights reserved. ZCS reserves the right to final interpretation. This manual is subject to change based on feedback from users, installers or customers. Please check our website at <http://www.zcsazzurro.com> for the latest version.

Technical support

ZCS offers a support and technical consultancy service accessible by sending a request directly from the website www.zcsazzurro.com

The following toll-free number is available for the Italian territory: 800 72 74 64.



1 About this manual

This Installation and user manual (hereinafter referred to as the manual) describes the installation, electrical connection, commissioning, maintenance and fault elimination procedures of following products:

AZZURRO 3PH HYD 30000 ZSR,

AZZURRO 3PH HYD 40000 ZSR,

AZZURRO 3PH HYD 50000 ZSR,

AZZURRO 3PH HYD 60000 ZSR.

- ▶ Carefully read this manual before use and retain it for future reference!
- ▶ Treat this manual as an integral component of the device.
- ▶ Keep this manual in close proximity to the device, including when it is handed over to another user or moved to a different location.

This manual contains important safety information on installation, operation and maintenance of the device.

- ▶ Read and observe all given safety information.

The products, services or features you purchased shall be subject to the company's commercial contracts and terms. All or part of the products and services described in this document may not within the scope of your purchase. Unless additional terms and conditions in your contract, the company does not make any statement or guarantee on the contents of this document.

1.1 Copyright declaration

The copyright of this manual is owned by Zucchetti Centro Sistemi Spa. It may not be copied – neither partially nor completely – by companies or individuals (including software, etc.) and must not be reproduced or distributed in any form, or with the appropriate means.

Zucchetti Centro Sistemi Spa reserves the right to final interpretation. This manual may be amended following feedback from users or customers.

Consult our website at: <https://www.zcsazzurro.com> for the latest version.

1.2 Presentation of warnings

This manual contains information on safe operation and uses symbols to ensure the safety of persons and property as well as the efficient operation of the inverter.

- ▶ Read through the following symbol explanations carefully in order to prevent injury or property damage.

1.2.1 Warning symbol

	<p>The general danger symbol warns of risk of serious injury when used with the signal words CAUTION, WARNING, and DANGER.</p>
---	--

1.2.2 Signal words

<p>DANGER</p>	<p>Indicates a hazardous situation which, if not avoided, will result in death or serious injury.</p>
<p>WARNING</p>	<p>Indicates a hazardous situation which, if not avoided, could result in death or serious injury.</p>
<p>CAUTION</p>	<p>Indicates a hazardous situation which, if not avoided, could result in minor or moderate injury.</p>
<p>NOTICE</p>	<p>Indicates a danger that results in damage to or destruction of the inverter.</p>

1.2.3 Sectional warnings

Sectional warnings refer to a complete section and are structured as follows:

 <p>WARNING</p>
<p>Type and source of danger</p> <p>Consequences for non observance</p> <ul style="list-style-type: none"> ▶ Avoiding the danger



1.2.4 Embedded warnings

Embedded warnings are part of an action sequence and are placed right before the dangerous step.

WARNING Combination of type/source of danger, consequences for non observance and avoiding the danger.

1.3 Presentation of action instructions

This table shows the sequence of Action steps:

Symbol	Function
✓	This describes an action requirement
1. 2. 3.	This is the sequence of action steps that must be followed step by step
▶	This is a single action step
↳	This describes the result of the action

1.4 Note

Notes are presented in a grey bar.

- ▶ Provides tips essential to the optimal operation of the product.

2 Basic safety information



- ▶ If you have any questions or problems after reading the following information, please contact Zucchetti Centro Sistemi Spa.

This chapter details the safety information pertaining to the installation and operation of the device.

2.1 Safety information

Read and understand the instructions within this manual and familiarise yourself with the relevant safety symbols in this chapter before beginning with the installation of the device and eliminating any faults.

Before connecting to the power grid, you must obtain official authorisation from the local power grid operator in accordance with the corresponding national and state requirements. Furthermore, operation may only be carried out by qualified electricians. Please contact the nearest authorised service centre if any maintenance or repairs are required. Please contact your dealer to obtain information about your nearest authorised service centre. Do NOT carry out repairs on the device yourself; this may lead to injury or property damage.

Before installing the device or carrying out maintenance on it, you must open the PV switch in order to interrupt the DC voltage of the PV generator. You can also switch off the DC voltage by opening the PV switch in the generation junction box. Not doing this may result in serious injury.

2.1.1 Qualified personnel

Personnel tasked with the operation and maintenance of the device must have the qualifications, competence and experience required to perform the described tasks, while also being capable of fully understanding all instructions contained within the manual.

For safety reasons, this inverter may only be installed by a qualified electrician who:



- ▶ has received training on occupational safety, as well as the installation and commissioning of electrical systems.
- ▶ is familiar with the local laws, standards and regulations of the grid operator.

Zucchetti Centro Sistemi Spa assumes no responsibility for the destruction of property or any injuries to personnel caused by improper usage.

2.1.2 Installation requirements

Please install the inverter according to the information contained in the following section. Mount the inverter to a suitable object with a sufficient load-bearing capacity (e.g. walls, PV frames etc.) and ensure that the inverter is upright. Choose a suitable place for the installation of electrical devices. Ensure that there is sufficient space for an emergency exit which is suitable for maintenance. Ensure sufficient ventilation in order to guarantee an air circulation for the cooling of the inverter.

2.1.3 Transport requirements

The factory packaging is specifically designed to prevent transport damage, i.e. violent shocks, moisture and vibrations. However, the device must not be installed if it is visibly damaged. In this case, notify the responsible transport company immediately.

2.1.4 Storage requirements

If the equipment is no longer to be put into service or is to be stored for a long period of time, make sure that the packaging is intact. Store the equipment in a well-ventilated indoor area that will not cause damage to the equipment components.

Store in a clean and dry place and protect from dust and moisture. Do not subject to rain or ground water erosion.

Do not tilt or invert the box. When stacking, place the inverter carefully to avoid personal injury or equipment damage caused by tipping the equipment. The maximum stacking layer number cannot exceed 5 layers

Keep the storage temperature around $-40^{\circ}\text{C}\sim 70^{\circ}\text{C}$. Relative humidity 5%~95% no condensation.



When restarting equipment that has been out of service for a long period of time, the equipment shall be thoroughly inspected.

2.1.5 Labelling on the device

The labels must NOT be concealed by items and foreign objects (rags, boxes, devices, etc.); they must be regularly cleaned and kept clearly visible at all times.

2.1.6 Electrical connection

Observe all applicable electrical regulations when working with the Solar inverter.

 DANGER
<p>Dangerous DC voltage</p> <ul style="list-style-type: none">▶ Before establishing the electrical connection, cover the PV modules using opaque material or disconnect the PV generator from the inverter. Solar radiation will cause dangerous voltage to be generated by the PV generator!
 DANGER
<p>Danger through electric shock!</p> <ul style="list-style-type: none">▶ All installations and electrical connections may only be carried out by trained electricians!

NOTICE
<p>Authorisation for grid feed-in</p> <ul style="list-style-type: none">▶ Obtain authorization from the local power grid operator before connecting the inverter to the public power grid.

Voiding of guarantee





- ▶ Do not open the inverter or remove any of the labels. Otherwise, Zucchetti Centro Sistemi Spa shall assume no guarantee.

2.1.7 Operation

DANGER

Electric shock

- ▶ Contact with the electrical grid or the device's terminals may result in an electric shock or fire!
- ▶ Do not touch the terminal or the conductor which is connected to the electrical grid.
- ▶ Follow all instructions and observe all safety documents that refer to the grid connection.

CAUTION

Burning due to hot housing

- ▶ While the inverter is being operated, several internal components will become very hot.
- ▶ Please wear protective gloves!
- ▶ Keep children away from the device!

2.1.8 Repair and maintenance

DANGER

Dangerous voltage!

- ▶ Before carrying out any repair work, first switch off the AC circuit breaker between the inverter and power grid, and then the PV switch.
- ▶ After switching off the AC circuit breaker and the PV switch, wait a minimum of 20 minutes before starting any maintenance or repair work.



NOTICE

Unauthorized repairs!

- ▶ Following the elimination of any faults, the inverter should be fully functional once more. Should any repairs be required, please contact a local authorized service centre.
- ▶ The internal components of the inverter must NOT be opened without the relevant authorization. Zucchetti Centro Sistemi Spa assumes no responsibility for any resulting losses or defects.

2.1.9 End-of-life requirements

When the inverter or other related components need to be disposed of, please ensure it is came out according to local waste handling regulations. Please be sure to deliver any inverter that needs to be disposed from sites that are appropriate for the disposal in accordance with local regulations.

2.2 Symbols and signs

⚠ CAUTION

Beware of burning hazards due to the hot housing!

- ▶ While the inverter is in operation, only touch the display and the buttons, as the housing can become hot.

NOTICE

Implement earthing!

- ▶ The PV generator must be earthed in accordance with the requirements of the local power grid operator!
- ▶ For reasons of personal safety, we recommend that all PV module frames and inverters of the PV system are reliably earthed.





⚠ WARNING

Damage due to overvoltage

- ▶ Ensure that the input voltage does not exceed the maximum permissible voltage. Overvoltage may cause long-term damage to the inverter, as well as other damage that is not covered by the warranty!







2.2.1 Symbols on the inverter

Several symbols pertaining to safety can be found on the inverter. Please read and understand the content of these symbols before starting the installation.

Symbol	Description
	Residual voltage is present in the inverter! Before opening the inverter, you should wait twenty minutes to ensure that the capacitor has been fully discharged.
	Caution! Danger through electric shock.
	Caution! Hot surface.
	The product is compliant with EU guidelines.
	Earthing point.
	Please read the manual before installing the inverter.





Symbol	Description
IP	Degree of protection of the device according to EN 60529.
+ -	Positive and negative poles of the DC input voltage.
	The inverter must always be transported and stored with the arrows pointing upward.
	A maximum of 5 layers can be stacked during the stacking process.
	Need to be moisture-proof and wet to store items in a clean and dry place.
	The cartons are packed with fragile goods and should be handled with care.
	The material can be recycled and recycled.
	Do not dispose of the equipment with household garbage at its end of life. Dispose of it according to local laws and regulations or send it to the manufacturer.



3 Product features

This chapter describes the product features, dimensions.

3.1 Product information

The AZZURRO 3PH HYD 30000...60000 ZSR is a hybrid inverter. It has integrated energy management functions which cover a wide range of application scenarios.

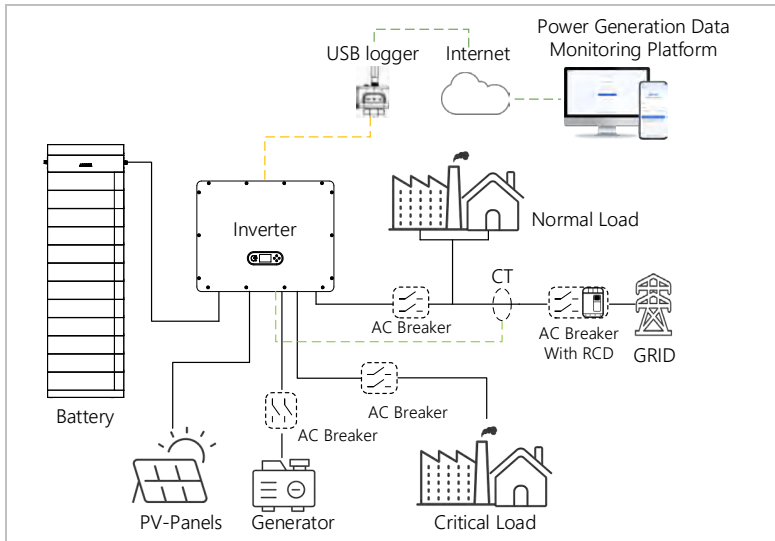

Figure 3-1 AZZURRO 3PH HYD 30000...60000 ZSR inverter system diagram

AZZURRO 3PH HYD 30000...60000 ZSR inverters may only be used with photovoltaic modules which do not require one of the poles to be earthed. In normal operation, the operating current must not exceed the limits specified within the technical data.

The selection of inverter accessories must be determined by a qualified technician familiar with the installation conditions.



3.2 Product dimensions

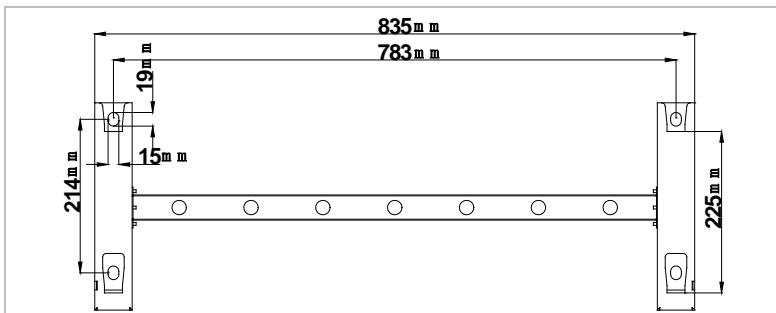
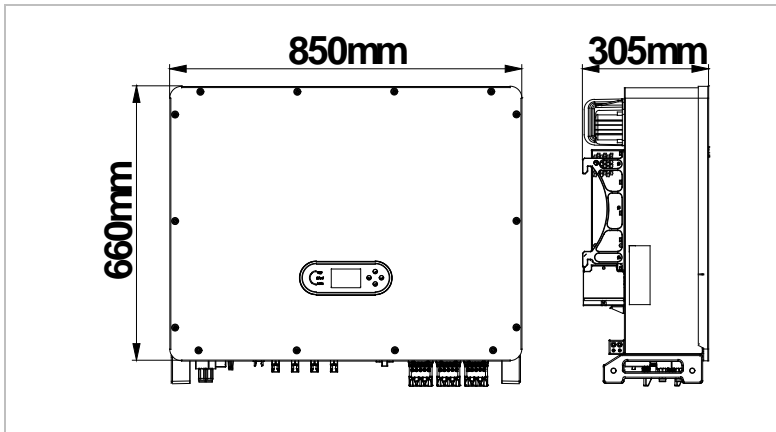

Figure 3-2 Dimensions



3.3 Labelling on the device

Labelling must not be covered or removed!

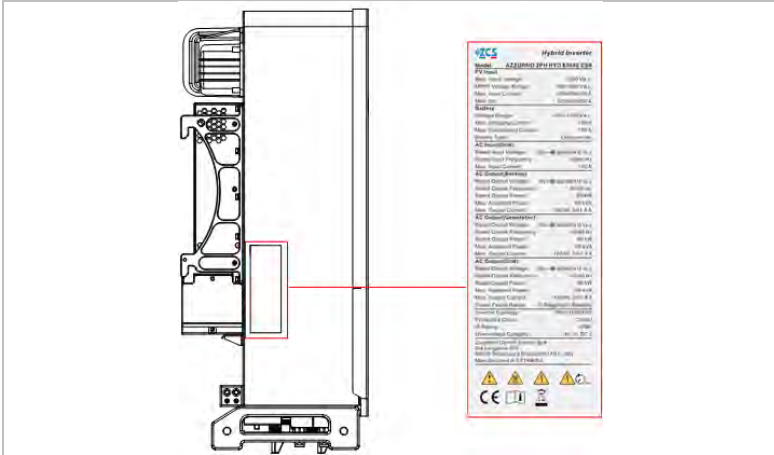

Figure 3-3 AZZURRO 3PH HYD 30000...60000 ZSR appearance and label

- The picture is only for reference, please make the object as the standard.

3.4 Electrical block diagram

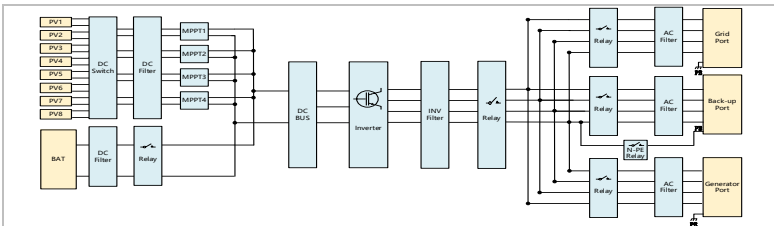

Figure 3-4 Electrical schematic diagram

3.5 Application modes

3.5.1 Typical energy storage system

A typical energy storage system with PV panels, generators and battery unit(s) connected to the grid.

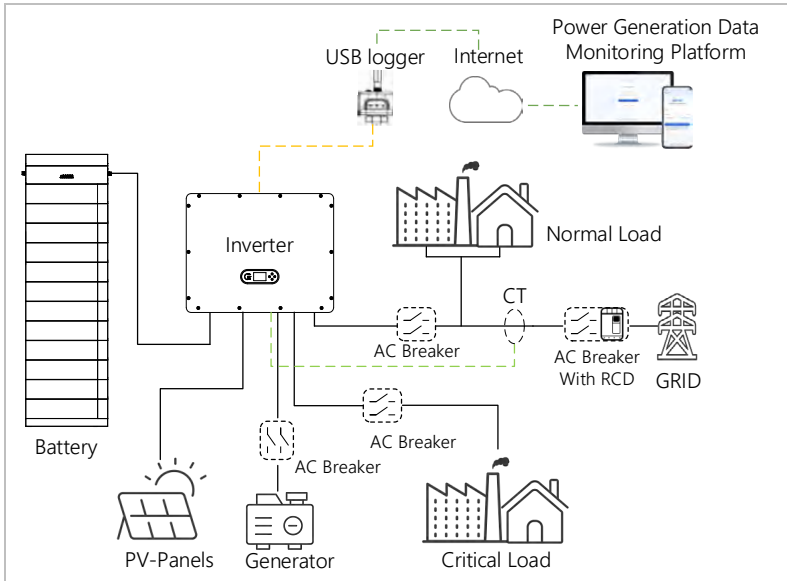

Figure 3-5 Typical energy storage system

3.5.2 System without PV connection

In this configuration, there are no PV panels connected and the battery is charged through generators or the grid connection.

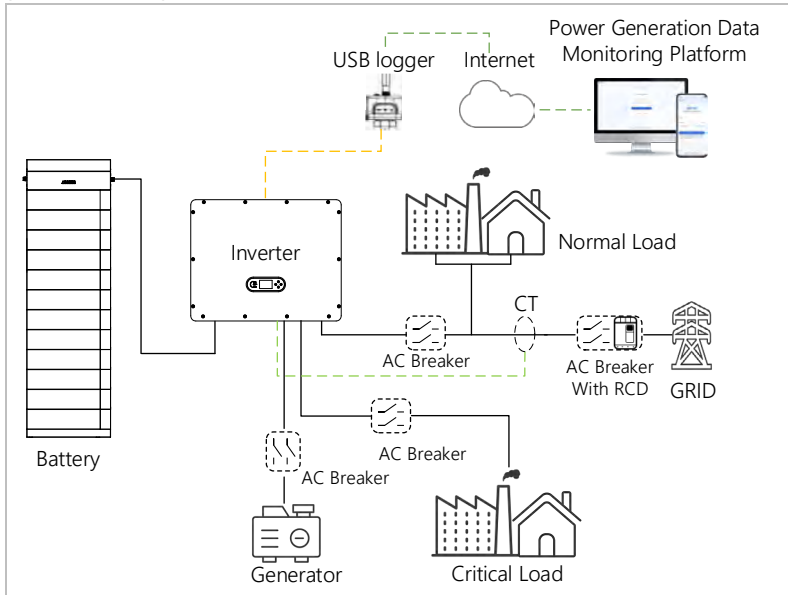

Figure 3-6 System without PV connection

3.5.3 System without battery

In this configuration, the battery unit(s) can be added later.

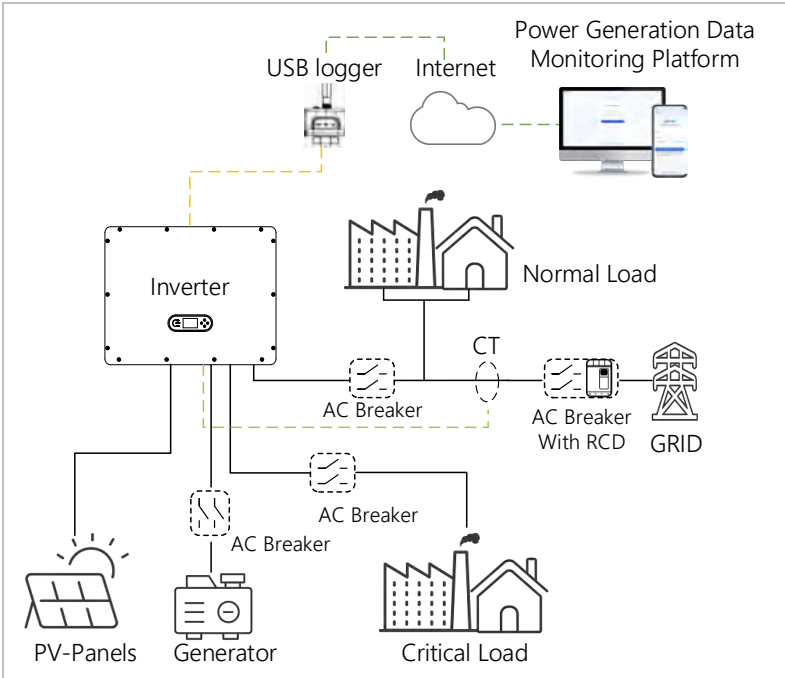

Figure 3-7 System without battery

3.5.4 Off-grid mode (Backup mode)

When there is no grid connection, the PV panels, generators and the battery will provide electricity to the critical load.

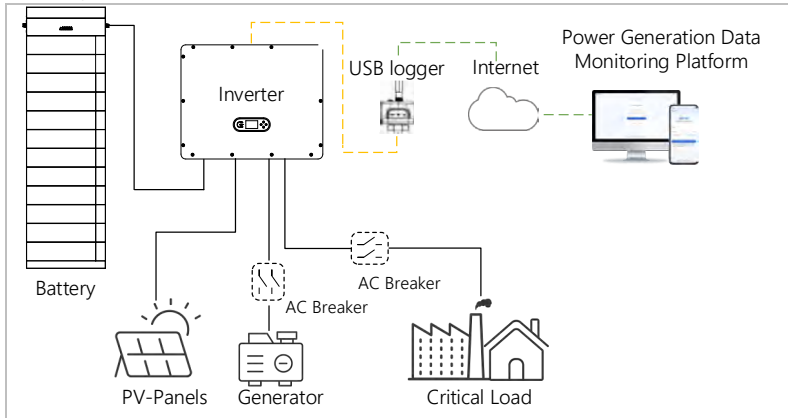

Figure 3-8 Off-grid mode

Off-grid carrying capacity

- ▶ In off-grid mode, the inverter's ability to support capacitive and inductive loads is $1/5$ of the single-phase rated power.

3.5.5 System with multiple inverters

In the on-grid mode, a maximum of 6 inverters can be connected in parallel.

In the off-grid mode, a maximum of 3 inverters can be connected in parallel.

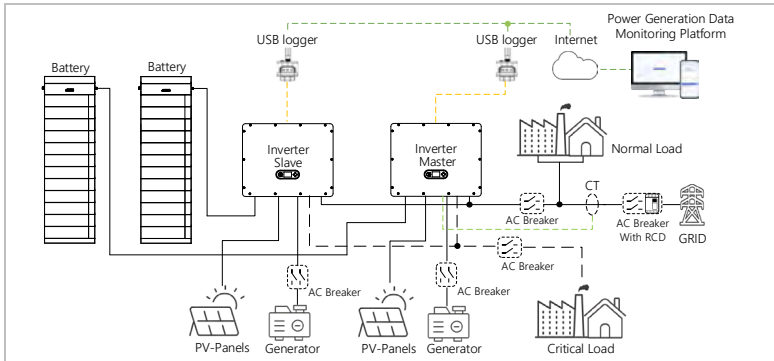

Figure 3-9 System with multiple inverter

- ▶ Multiple inverters connected in parallel shall be of the same power model with the same power and battery configuration.
- ▶ The smart meter or CTs are connected to the Master inverter. Control of all inverters takes place via the link cable.
- ▶ For the parallel switching of several devices, it is recommended to use a joint AC break switch for the connected loads at the LOAD connection.
- ▶ For the parallel switching of several devices, it is recommended to use a joint AC break switch for the connected loads at the GRID connection.
- ▶ In order to evenly distribute the loads among the inverters, the cable length between each output and the load must be the same.
- ▶ If the maximum apparent power of a load is greater than 110% of the inverter's rated output, the device must not be connected via the BUCKUP terminal, but rather directly to the grid.



3.5.6 AC retrofit system

In this system configuration, the hybrid system for an already existing PV system is supplemented with a solar inverter of any brand. By installing a second smart meter, the PV production can be taken into account.

- ▶ Only CHINT or Acrel smart meters are supported, and the models of Meter1 and Meter2 must be consistent.
- ▶ The address for the PCC Meter1 should be set to 1. If there are multiple meters for photovoltaic inverters, their addresses should be set individually from 2 to 4 without duplication.

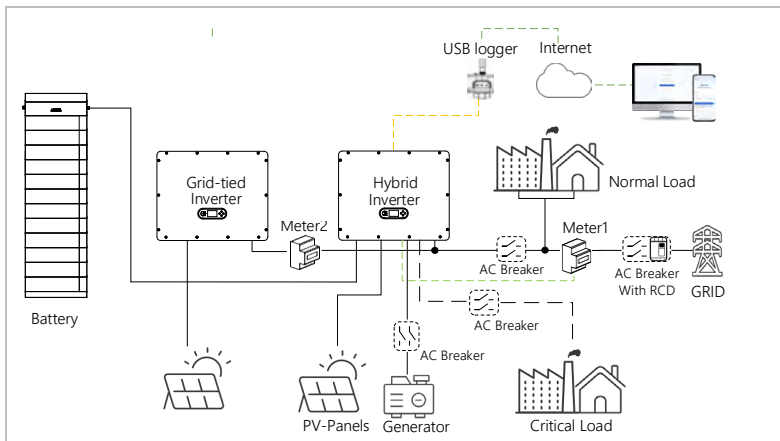

Figure 3-10 AC retrofit system

3.5.7 Unbalanced Support

By enabling the “Unbalanced Support” option, the inverter compensates unbalanced loads either in EPS mode and on grid mode. In this mode, it supports connecting to 100% unbalanced loads.

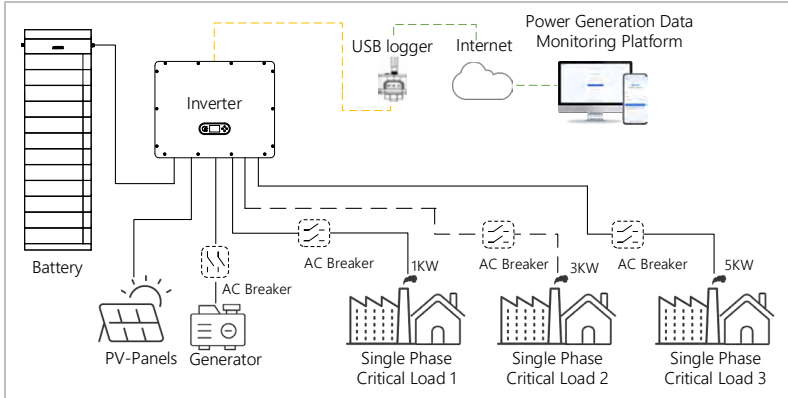

Figure 3-11 Unbalanced Support (EPS mode)

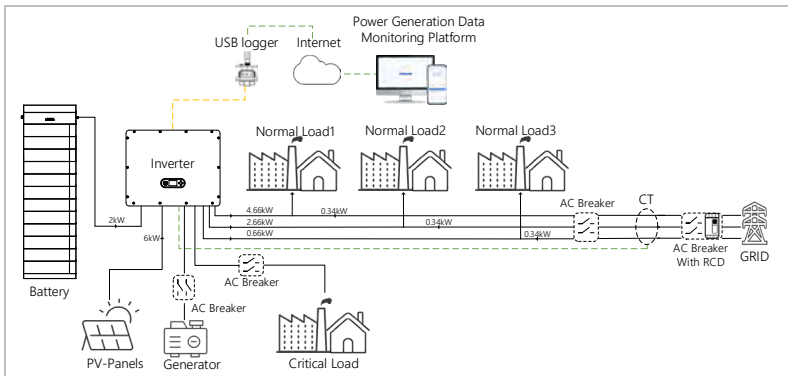

Figure 3-12 Unbalanced Support (On Grid)



4 Installation

4.1 Installation information



DANGER

Fire hazard

- ▶ Do NOT install the inverter on flammable material.
- ▶ Do NOT install the inverter in an area in which flammable or explosive material is stored.



CAUTION

Burning hazard

- ▶ Do NOT install the inverter in places where it can be accidentally touched. The housing and heat sink may become very hot while the inverter is being operated.

NOTICE

Weight of the device

- ▶ Take into account the weight of the inverter when transporting and moving it.
- ▶ Choose a suitable installation location and surface.
- ▶ Commission a minimum of two persons for the installation of the inverter.
- ▶ Do not set down the inverter overhead.



4.2 Installation procedure

Mechanical installation is performed as follows:

1. Examine the inverter before installation.
2. Prepare the installation.
3. Select an installation location.
4. Transport the inverter.
5. Mount the rear panel.
6. Install the inverter.
7. Install the Battery.

4.3 Examination before installation

4.3.1 Checking the external packaging materials

Packaging materials and components may become damaged during transportation. Therefore, the external packaging materials must be examined before the inverter is installed. Check the external packaging material for damage, e.g. holes and cracks. If you discover any damage, do not unpack the inverter and contact the transport company and/or dealer immediately. It is recommended that the packaging material should be removed within 24 hours before installing the inverter.



4.3.2 Checking the delivery scope







After unpacking the inverter, check that the delivery items are both intact and complete.

In the event of any damage or missing components, contact the wholesaler.

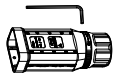
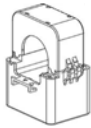
NO.	Image	Description	Quantity Pcs.
01		Inverter AZZURRO 3PH HYD 30000...60000 ZSR	1
02		Wall bracket	1
03		PV+ input terminal	9
04		PV- input terminal	9
05		Connector contact PV+	9
06		Connector contact PV-	9
07		M6*12 hexagon screw	5
08		M10*90 expansion screws (wall bracket)	5
09		M6*30 hexagon screw	3

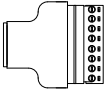
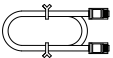
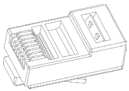



NO.	Image	Description	Quantity Pcs.
10		AC grid connection AC load connection Generator connection	3
11		CT, Assembly- Φ 36mm mouth-line	3
12		COM connector cable end	1
13		RJ45 Female to 8PIN solderless terminal network extender	1
14		5-meter communication cable (For Meter/CT)	1
15		Matching resistance	2
16		Quick installation guide	1
17		User Manual	1
18		Outgoing inspection report	1





4.4 Connections

⚠ CAUTION

Damage during transportation

- ▶ Please check the product packaging and connections carefully prior to installation.

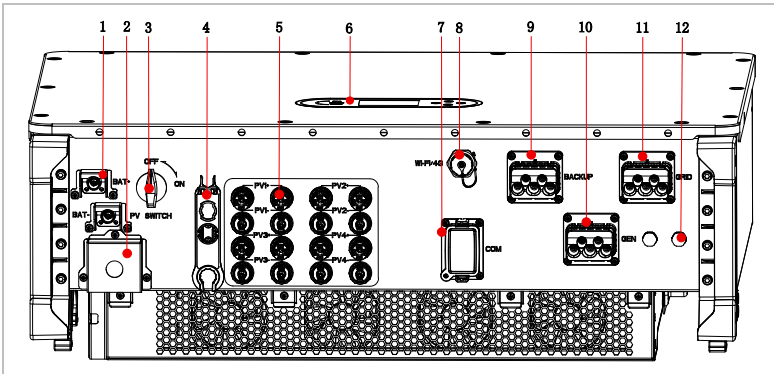

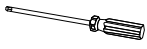



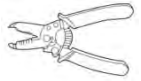
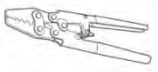

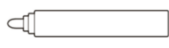

Figure 4-1 AZZURRO 3PH HYD 30000...60000 ZSR inverter overview

1	Battery connection	2	Explosion proof valve
3	PV switch	4	PV terminal remover
5	PV input terminals	6	LCD display
7	Communication connection	8	Wi-Fi /4G
9	AC backup connection	10	AC generator connection
11	AC grid connection	12	Breathable valve



4.5 Tools

Prepare the tools required for the installation and the electrical connection.

No.	Tool	Model	Function
01		Hammer drill Recommended drill diameter: 12 mm	Used to drill holes in the wall
02		Hexagon Screwdriver	Fixed inverter and PE wiring
03		Phillips screwdriver	Used to remove and install the screws of the Battery DC cable protective cover
04		With an open end of larger than or greater than 32 mm	Used to tighten expansion bolts
05		Rubber Mallet	Used to hammer expansion bolts into holes
05		Wire stripper	Used to strip the wire
07		Crimping tool	Used to crimp power cables
08		Multimeter	Used to check the earthing
09		Marker	Used for marking



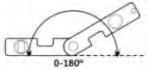
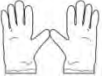

No.	Tool	Model	Function
10		Measuring tape	Used to measure distances
11		Spirit level	Used to align the wall bracket
12		ESD gloves	for the installer
13		Safety goggles	for the installer
14		Anti-dust respiratory mask	for the installer

4.6 Installation Environment Requirements

1. Choose a dry, clean, and tidy place, convenient for installation.
2. Ambient temperature range: $-30\sim+60^{\circ}\text{C}$ (derating above $+45^{\circ}\text{C}$).
3. Relative humidity: $5\sim95\%$ (non-condensed).
4. The inverter shall be installed in a well-ventilated place.
5. Do not place the inverter close to flammable or explosive materials.
6. The AC overvoltage category of the inverter is category III.
7. Maximum altitude: 4000m (derating above 2000m)
8. Pollution degree: 4



4.7 Installation location

Choose a suitable position for the installation of the inverter. Ensure that the following requirements have been fulfilled:

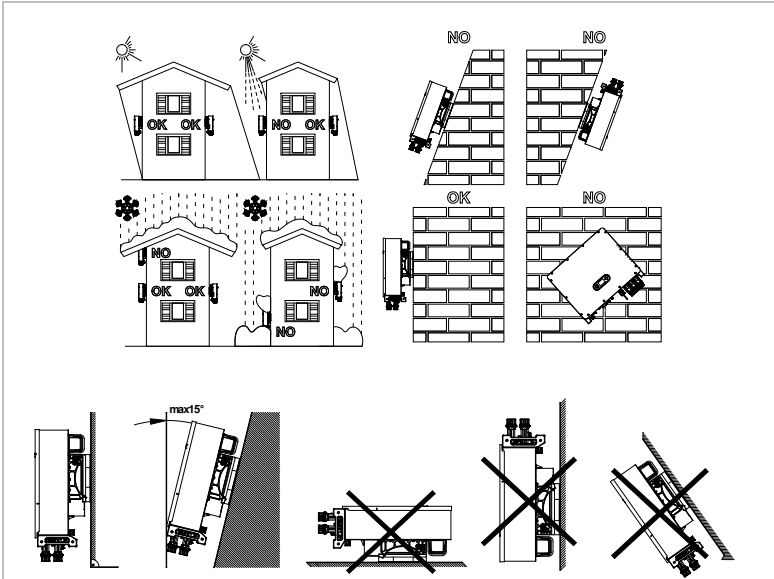

Figure 4-2 Installation position of AZZURRO 3PH HYD 30000...60000 ZSR

Minimum distances for individual AZZURRO 3PH HYD 30000...60000 ZSR inverters:
500...800mm.

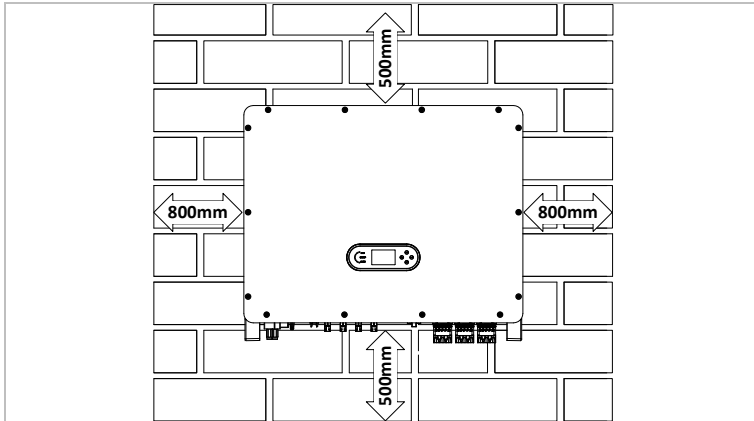

Figure 4-3 Minimum distances for individual inverter





Minimum distances for several AZZURRO 3PH HYD 30000...60000 ZSR inverters:

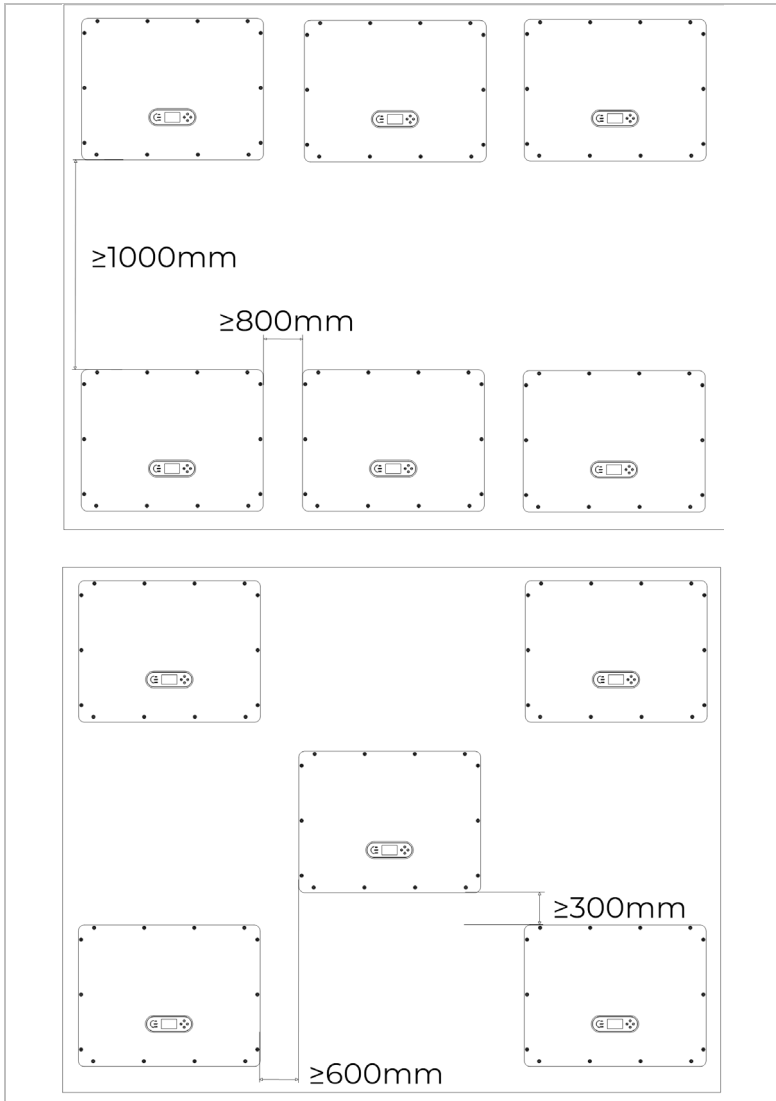

Figure 4-4 Minimum distances for several inverter





4.8 Unpacking the inverter

1. Unload the inverter from package, horizontally move to the install position. When open the package, at least two operators insert the hands into the slots on both side of the inverter and hold the handles to remove the inverter.
2. Lift the inverter out of the packaging and move it to its installation position.

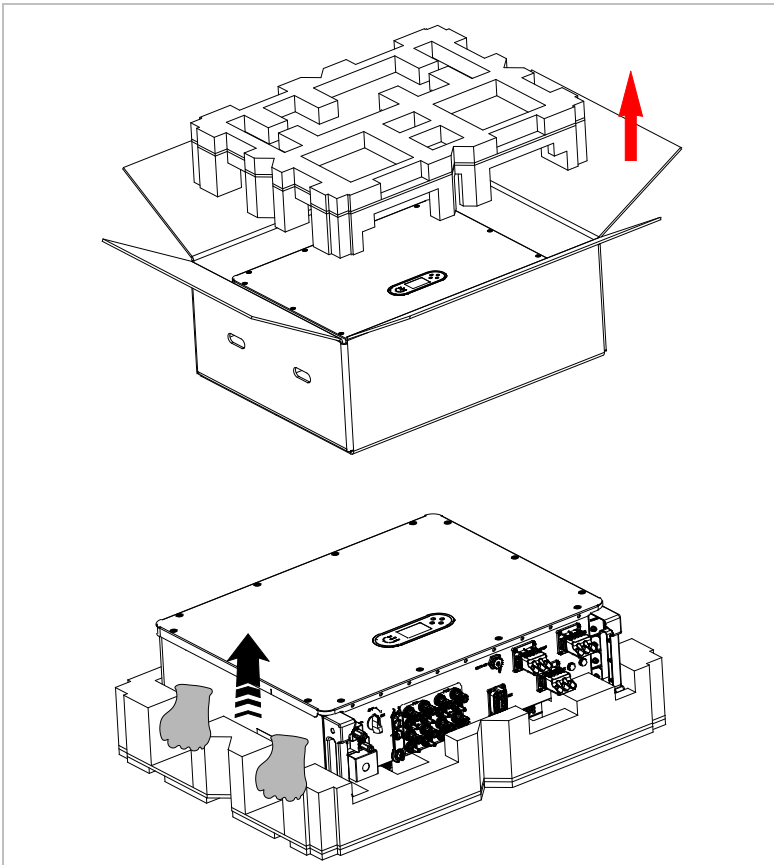

Figure 4-5 Moving the inverter



NOTICE

Mechanical damage

- ▶ In order to prevent injuries and damage to the device, ensure that the inverter is kept balanced while it is being moved - it is very heavy.
- ▶ Do not put the inverter with wiring terminals contacting the floor because the power ports and signal ports are not designed to support the weight of the inverter.
- ▶ When you place the inverter on the ground, place foamed material or paper underneath it in order to protect its housing.

4.9 Installation of the inverter

1. Placed the wall bracket on the mounting wall, determine the mounting height of the bracket and mark the mounting poles accordingly. Drilling holes by using Hammer Drill, keep the hammer drill perpendicular to the wall and make sure the position of the holes should be suitable for the expansion screws.

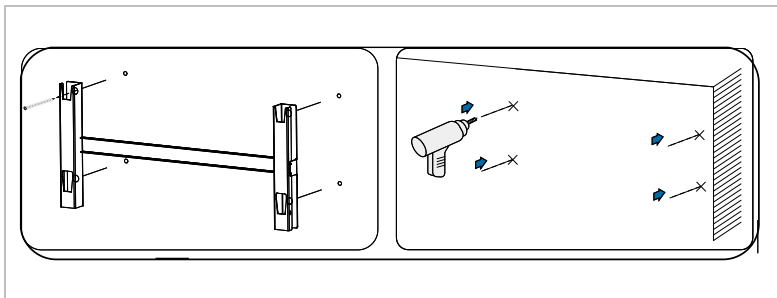

Figure 4-6 Drilling holes on the mounting wall



2. Insert the expansion screws vertically into the hole.

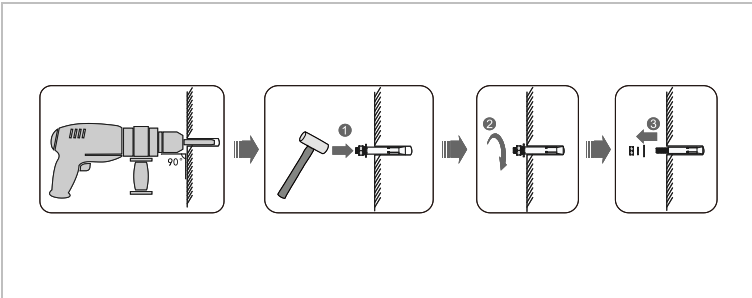

Figure 4-7 Screws into the holes

3. Align the wall bracket with the hole positions, fix the wall bracket on the wall by tightening the expansion screws with the nuts.

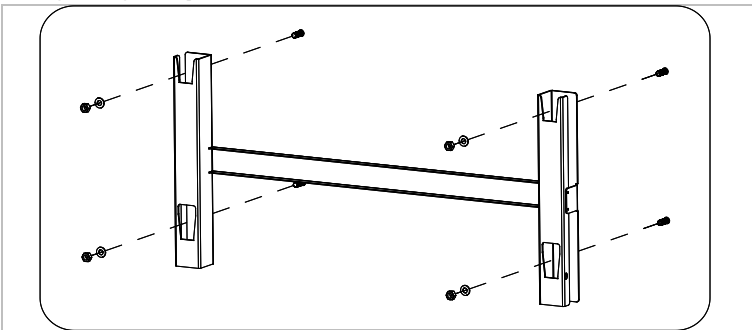

Figure 4-8 Install wall bracket

4. Lift the inverter and hang it on the wall bracket, and fixing both side of inverter with M6*30 screw (accessories).

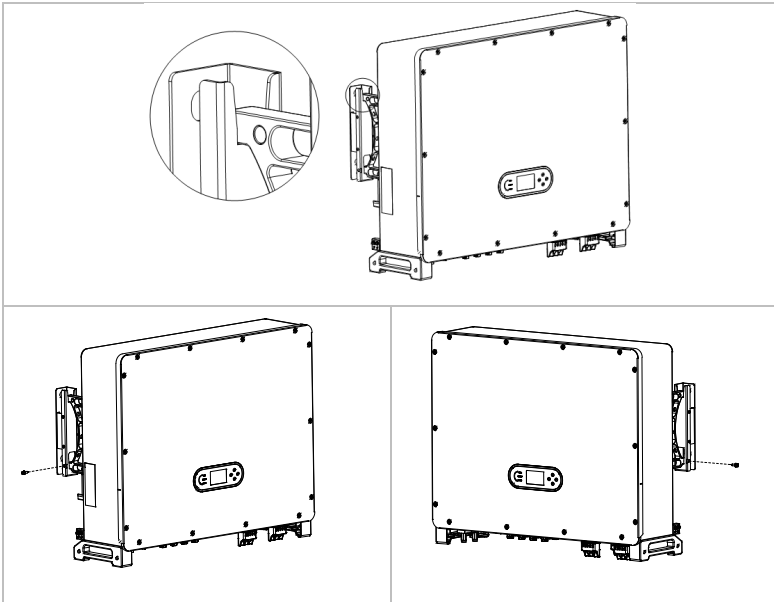

Figure 4-9 Fix inverter





4.10 Configurations Battery for Inverter

4.10.1 Configurations AZZURRO HV ZBS8000 Battery for inverter

Each cluster of stacked batteries can expand up to six battery modules. The ZBS8000 battery module has a nominal capacity of 16 kWh and the standard configuration of the AZZURRO 3PH HYD 30000...60000 ZSR system has a capacity ranging from 64,31 - 80,8 - 96,46 kWh.

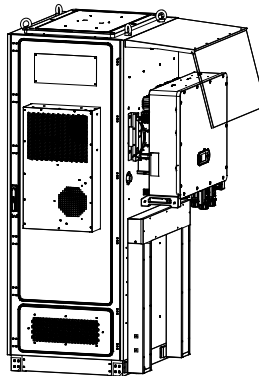

An example of a possible configuration for the AZZURRO 3PH HYD 40000-50000 ZSR is 96 kWh.

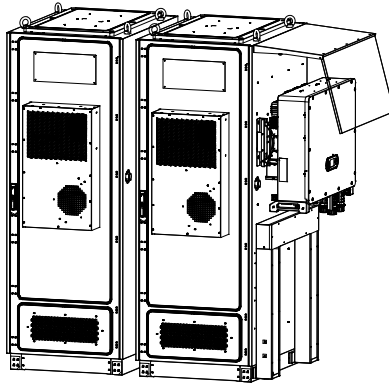

An example of a possible configuration for the AZZURRO 3PH HYD 60000 ZSR is 96-192 kWh.

Figure 4-12 Number of battery modules and system capacity(c)

Note:

- ▶ The cases described above are provided for illustrative purposes only. It is the responsibility of the system designer, on a case-by-case basis, to correctly size the capacity to be associated with the inverter, according to the inverter's rated power and the power demand of the loads.





5 Electrical connections

5.1 Safety instructions

This topic describes the electrical connections of the inverter AZZURRO 3PH HYD 30000...60000 ZSR. Read this section thoroughly and carefully before connecting the cables.

DANGER

Electrical voltage at the DC connections

- ▶ Ensure that the PV switch is OFF before establishing the electrical connection. The reason is that the electrical charge remains in the capacitor after the PV switch has been switched off. Therefore, at least 20 minutes must lapse before the capacitor has been electrically discharged.

DANGER

Electrical voltage

- ▶ PV modules generate electrical energy when exposed to sunlight, and this may present an electrical shock hazard. Therefore, cover the PV modules with an opaque sheet before connecting to the DC input power cable.

DANGER

Electrical voltage at the DC connections

- ▶ Wear rubber gloves and protective clothing (safety goggles and boots) when working on high voltage/high current systems such as inverter and battery systems.



⚠ DANGER

Electrical voltage at the EPS connections

- ▶ Consumers must not remove the EPS plug from the inverter.

NOTICE

Qualification

- ▶ The installation and maintenance of the inverter must be carried out by an electrician.

NOTICE

On-grid operation

- ▶ After connecting the external terminals of the inverter, the recommended power-up sequence is: first turn on the battery, then turn on DC, then connect to the grid, and finally connect the load.
- ▶ After connecting the external terminals of the inverter, the recommended de-energizing sequence is: first disconnect the load, then disconnect DC, then disconnect the battery, and finally disconnect the grid.



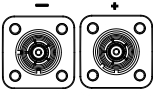
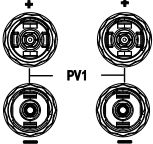
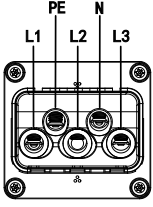

5.2 Wiring overview

Component	Description	Recommended cable type					
	<p>+ : Connect the positive cable of the lithium battery</p> <p>- : Connect the negative cable of the lithium battery</p>	Outdoor copper cable (20...25mm ²)					
	<p>+ : Connect the positive cable of the PV array</p> <p>- : Connect the negative cable of the PV array</p>	PV cable (4...6mm ²)					
 <p>Load</p> <p>Grid</p> <p>Generator</p>	<p>Connection method: cable conductors (no insulation layer) are completely inside the conductor insertion points. Tighten the cable conductors to a torque of 4 N·m.</p>	<table border="1"> <tr><td>L1</td></tr> <tr><td>L2</td></tr> <tr><td>L3</td></tr> <tr><td>N</td></tr> <tr><td>PE</td></tr> </table> <p>Outdoor multicore copper cable AZZURRO 3PH HYD 30000...60000 ZSR 20...25mm²</p>	L1	L2	L3	N	PE
L1							
L2							
L3							
N							
PE							

- The selection of the cable cross-section must take into account the length of the cable used and the circuit breaker according to the national standard.

5.3 System Electrical Topology

The inverters AC GRID and BACKUP are wired with different N and PE wires depending on the regulatory requirements in different regions. For users in Australia, South Africa and New Zealand, please use the System Electrical Topology in Figure 5-2.

System 1: Internal relay controls N-PE grounding

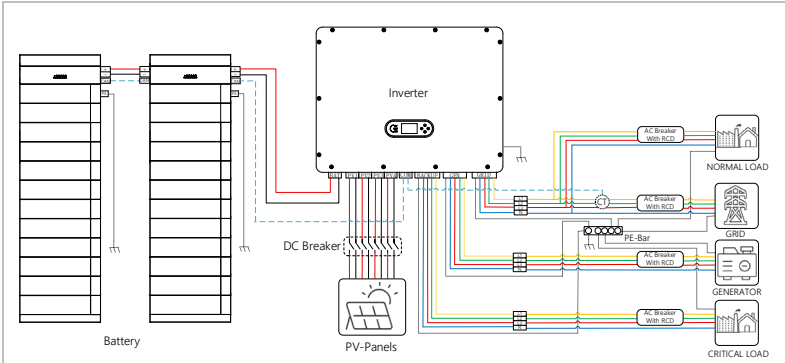

Figure 5-1 System Electrical Topology (General)

- ▶ Ensure that both the BACKUP and GRID PE wires are grounded at the same time, as shown in the diagram. Otherwise, the inverter may be abnormal in off-grid mode.
- ▶ In system 2, Neutral Point Grounding is disabled by default. Check whether Neutral Point Grounding is enabled, if not, enable it manually: Advanced Setting -> Input 0715 -> Neutral Point Grounding->Enable



System 2: N and PE wires are connected together

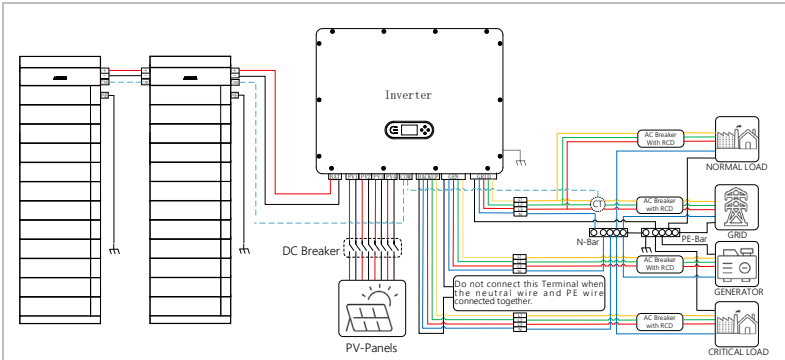

Figure 5-2 System Electrical Topology

(For Australia, South Africa and New Zealand)

⚠ DANGER

Install Residual current device (RCD) in front of the load

- ▶ RCD is necessary for critical load, but optional for normal load.
- ▶ In off-grid mode, the EPS switch is unprotected and load leakage could lead to shock danger.
- ▶ The Entry master switch installed in the house must have earth leakage protection and its rated earth leakage action current $>$ number of inverters * 100mA (suggestive value).

⚠ DANGER

Be sure to ensure that the output is grounded.

- ▶ In system 1, the PE line of the inverter's AC GRID Port, AC BAKUP Port and AC GEN port must be grounded through the PE-Bar, otherwise there may be a risk of leakage.



- ▶ According to the **Australian safety regulations**, the neutral cables on the grid-connected side and BACKUP side must be connected together. Otherwise, the BACKUP cannot be used.

5.4 Meter/CT

There are different system configurations possible depending on the user's requirements, existing electrical infrastructure and local regulations. The distribution box must be configured to comply to the grid operator requirements.

The inverter has an integrated AC relay to disconnect all phases and Neutral from the grid in case of grid fault or grid outage.

The inverter's generation and feed-in limit functions require the use of an external measurement device to obtain grid information.

There are 2 system configurations:

System A: direct measurement of energy with CT's (8000:1) – Default configuration.

System B: measurement with smart meter + CTs.

- ▶ The secondary side current of Scheme A is less than **50mA**. The length of the lead of CT cannot exceed **50m**. If distances exceeding 50m, please using **System B** (measurement with smart meter + CTs). Please do not use power lines for CT and smart meters, and use the CAT5E cable with T568B.
- ▶ When the effective value of the measured current is $< 300A$, it is recommended to use System A, which comes standard with CT (8000:1) and CT signal line (5 meters) at the factory.
- ▶ When the effective value of the measured current is $\geq 300A$, it is recommended to use System B. It is necessary to purchase an additional Zucchetti Centro Sistemi Spa electric meter accessory package (including smart meters and external CT).





5.4.1 System A: direct measurement with CT's (8000:1) - Default configuration

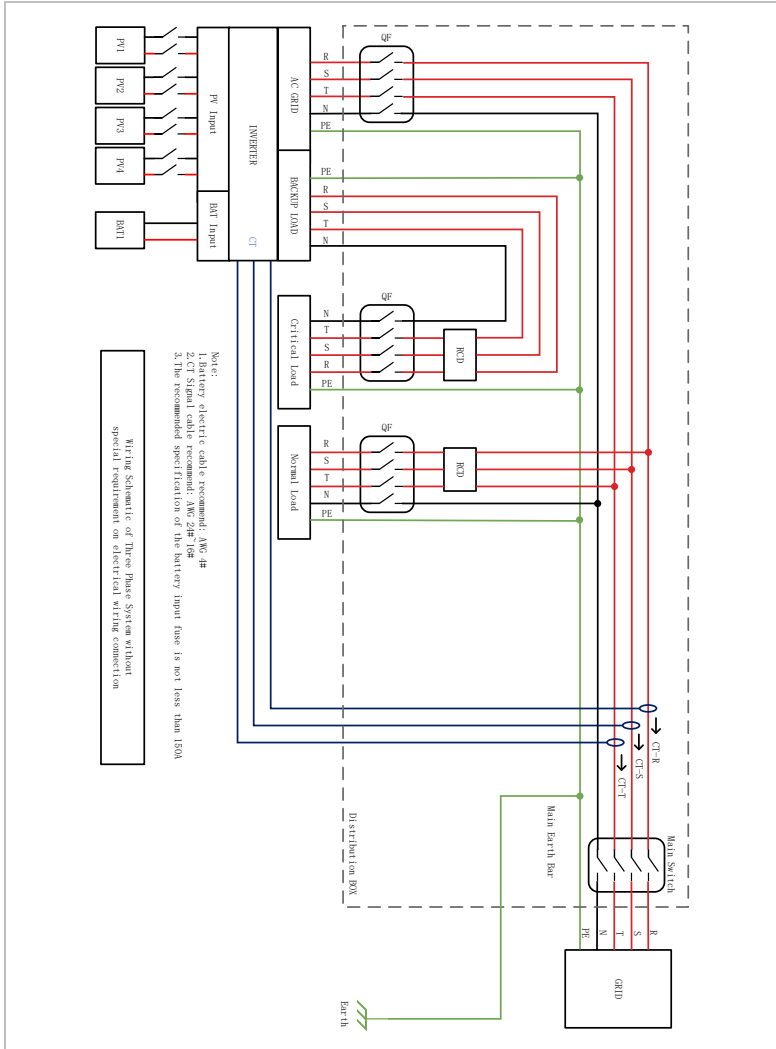

Figure 5-3 Electrical connections (Plan A: CT)

5.4.2 System B: measurement with smart meter + CTs

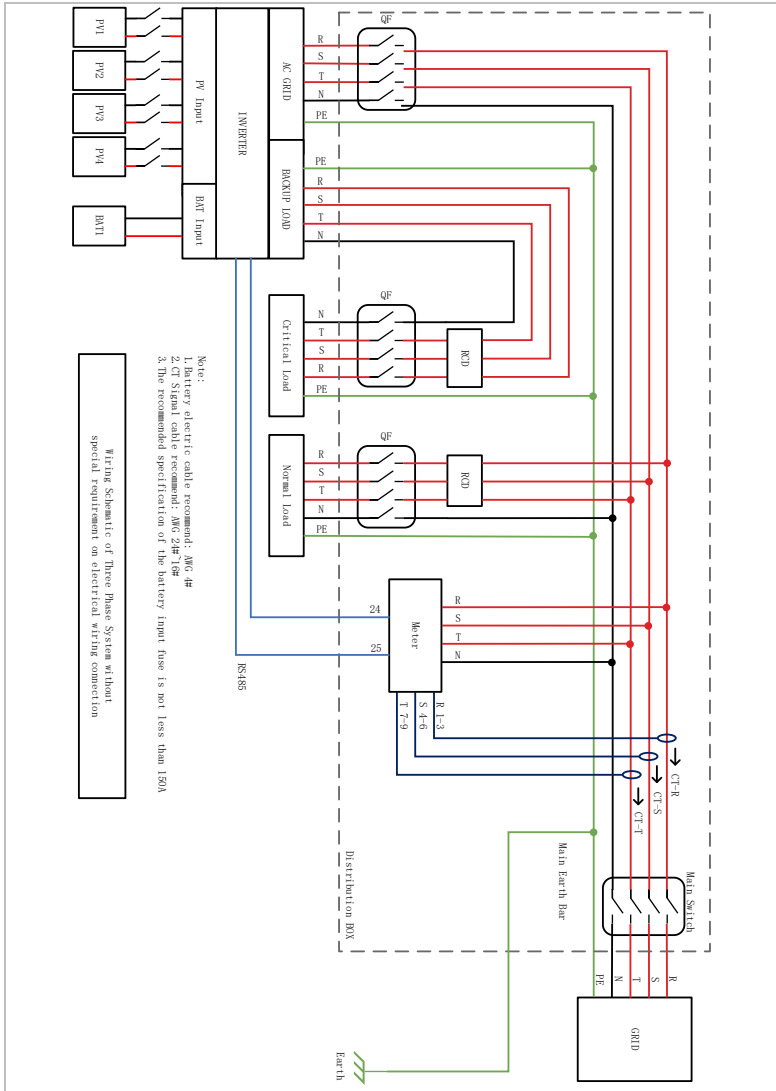

Figure 5-4 Electrical connections (Plan B: Meter + CTs)



System A: CT 400A/50mA Default(8000:1)

CT Technical Data	
Rated primary current	400 A
Rated secondary current	50mA
Rated operating frequency	50/60 Hz

System B: Smart Meter with CT

Meter Technical Data	
Nominal voltage	3×220/380V...3×240/415V, 50 Hz/60 Hz
Voltage measurement range	3×57.7/100V...3×288/500V
Electricity metering accuracy	Class C (0.5S)
Power grid system	three-phase four-wire
Baud rate	1200/2400/4800/9600/19200/115200 bps (default value: 9600 bps)
Operating temperature	-25°C~+55°C(nominal), -40°C~+70°C(ultimate)
Way to install	Rail mounting

CT Technical Data	
Rated primary current	400A/500A/600A/800A
Rated secondary current	5A
Rated operating frequency	50/60 Hz
Perforated size	36/50mm Diameter



5.5 Electrical connection

The electrical connection is established as follows:

1. Connect PE cable.
2. Connect PV input cable.
3. Connect battery cable.
4. Connect AC output power cable.
5. Connect communication cable.

5.6 Connecting the PE cables

Connect the inverter to the equipotential bonding bar by using the protective earth cable (PE) for grounding.

NOTICE

Pole earthing not permissible!

- ▶ As the inverter is transformerless, the plus and minus poles of the PV generator must NOT be earthed. Otherwise, the inverter will malfunction. In the PV system, not all live metal parts (e.g. PV module frames, PV frame, generator connection box housing, inverter housing) require earthing.
 - ▶ The protective grounding of the chassis shell cannot replace the PGND cable of the BACKUP Port. Ensure that the two PGND cables are reliably connected.
 - ▶ When multiple inverters are deployed, ensure that the protection ground points of all inverters are equipotential connected.
1. Remove the insulation of the cable. For outside use, the PE cable recommended for use in EU depends on the protection breakers used and the length of cable, it is recommended to use: PE cable $\geq 16\text{mm}^2$, copper wire.

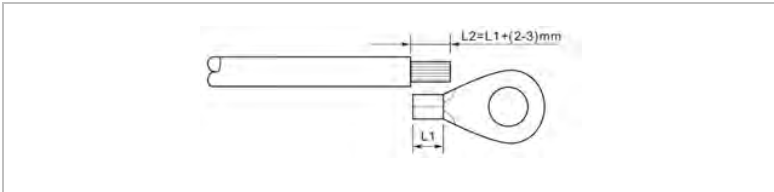

Figure 5-5 Connecting PGND cable(a)

► L2 is 2 to 3 mm longer than L1

2. Crimp the cable to the ring terminal:

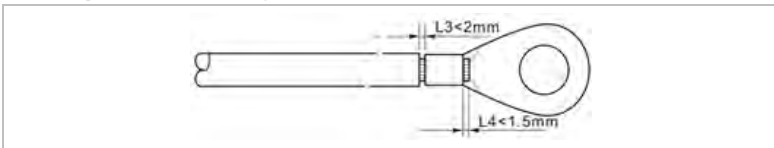

Figure 5-6 Connecting PGND cable(b)

3. Install the crimped ring terminal and the washer with the M6*12 screws and tighten these with a torque of 8 Nm using an Allen key:

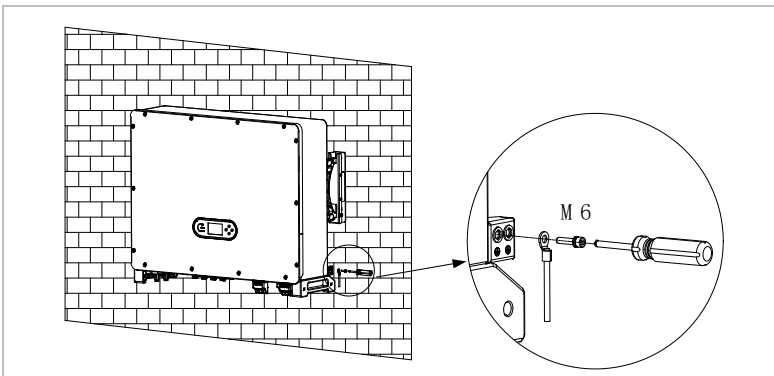

Figure 5-7 Connecting PGND cable(c)

5.7 Connecting the DC cable for the PV modules and battery

5.7.1 Connecting the PV modules

Please observe the recommended cable dimensions:

Cable cross-section (mm ²)		Outer diameter of cable (mm)
Range	Recommended value	
4.0 ... 6.0	4.0	4.5 ... 7.8

1. Remove the crimp contacts from the positive and negative connections.
2. Remove the insulation of the cables:

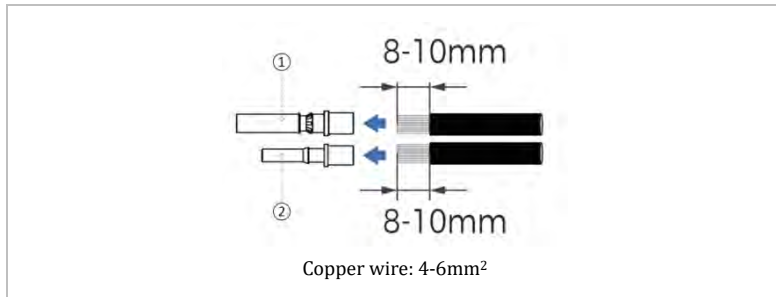

Figure 5-8 Connecting PV(a)

- | | | | |
|---|-------------------|---|-------------------|
| ① | Positive DC cable | ② | Negative DC cable |
|---|-------------------|---|-------------------|

- ▶ L2 is 2 to 3 mm longer than L1

3. Insert the positive and negative DC cables into the corresponding cable glands.
4. Crimp the DC cables. The crimped cable must be able to withstand a tractive force of 400 N · m.

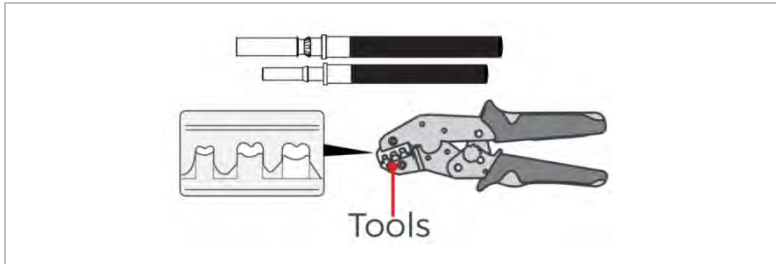

Figure 5-9 Connecting PV(b)

⚠ CAUTION

Danger of reverse polarity!

- ▶ Ensure that the polarity is correct before plugging into the DC connections!

5. Insert the crimped DC cables into the corresponding connector housing until you hear a “clicking” sound.

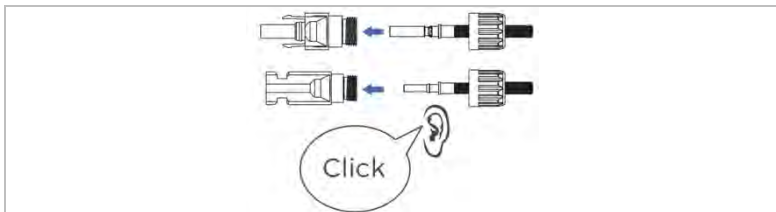

Figure 5-10 Connecting PV(c)

6. Re-screw the cable glands to the connector housing.

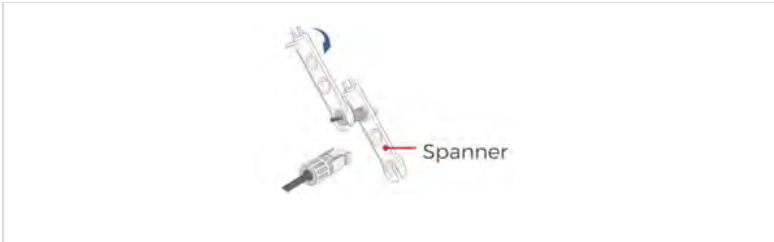

Figure 5-11 Connecting PV(d)

7. Use a multimeter to measure the voltage at both ends of the positive and negative terminals to ensure that the terminals are connected reliably.

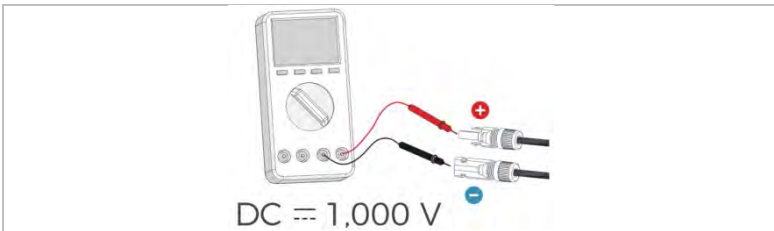

Figure 5-12 Testing PV(e)

8. Insert the positive and negative connectors into the corresponding DC input terminals of the inverter until you hear a “clicking” sound.

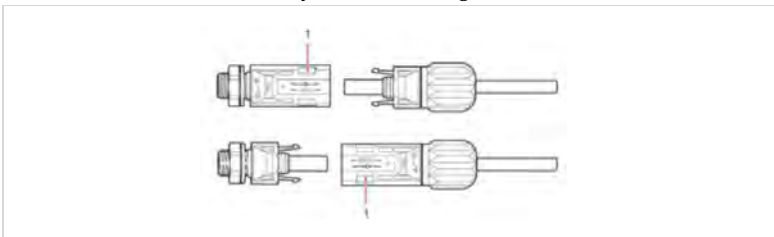

Figure 5-13 Connecting PV(e)

- ▶ Insert the protective caps into the unused DC connections.

Removing the connectors





⚠ CAUTION

Danger of DC arcing

- ▶ Before removing the plus and minus connector, ensure that the PV switch has been set to OFF.

In order to remove the plus and minus connection from the inverter, insert a removal key into the locking and press on the key with the adequate force as shown in the following illustration:

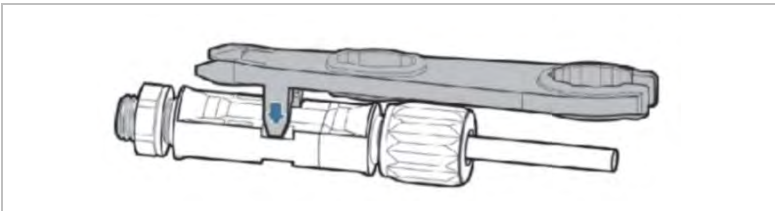

Figure 5-14 Connecting PV(f)

5.7.2 Connecting the DC cable of battery

Connect the Battery ports (BAT+, BAT-) of the inverter to the cascading positive and negative power cables (P+, P-) of the battery.

Please refer to the following figure for the specific installation method of battery DC cable connection:

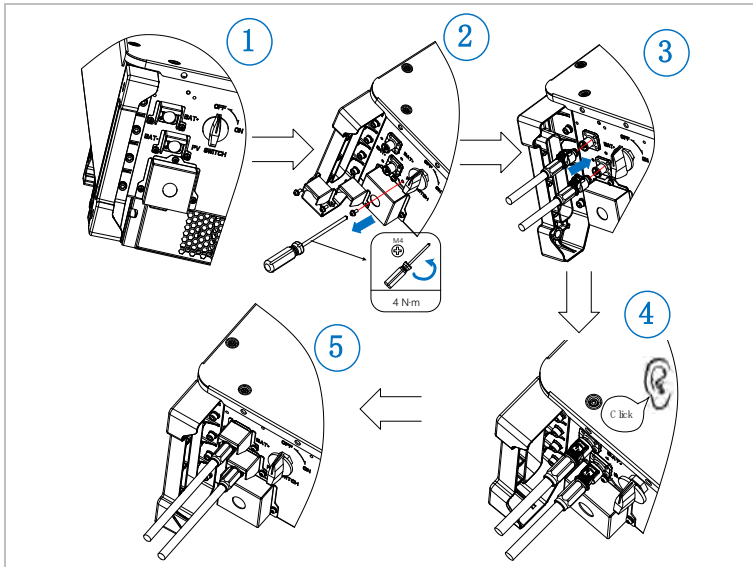

Figure 5-15 Connection of battery internal DC terminal

5.8 Connecting the AC power cables

The AC power cables are used to connect the inverter to the critical loads (through the BACKUP port), and the AC power distributor or the power grid.

⚠ CAUTION

AC connection

- ▶ Each inverter must have its own circuit breaker.
 - ▶ The AC disconnecting device must be easily accessible.
-
- ▶ The inverter AZZURRO 3PH HYD 30000...60000 ZSR has a GFCL.
For the selection of the **RCD type to be installed on the grid side**, please refer to the document **“Declaration for the use of RCD devices”**.
For the **load output**, use a **30 mA RCD**.



- ▶ Please follow the national rules and regulations for the installation of external relays or circuit breakers!

The AC cable should be correctly dimensioned in order to ensure that the loss of power in the AC cable is less than 1% of the rated output. If the AC cable resistance is too high, then the AC voltage will increase; this may cause the inverter to become disconnected from the power grid. The relationship between the loss power in the AC cable and the cable length, the cable cross-section, is displayed in the following illustration:

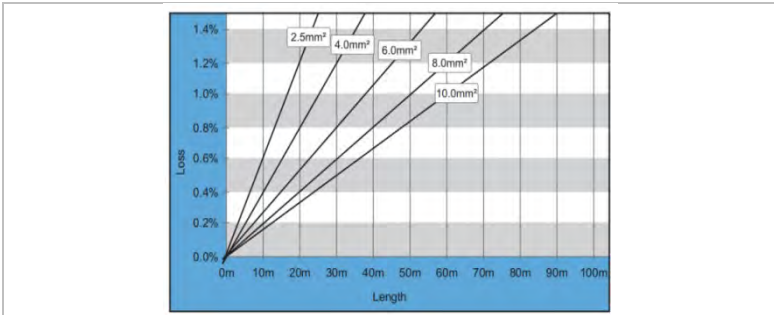

Figure 5-16 The relationship between the leakage power and cable length



5.9 AC connector installation

⚠ CAUTION

Electrical voltage

- ▶ Ensure that the grid has been switched off before removing the AC connector

- ▶ There are three types of AC connectors, namely AC grid terminal, AC load terminal and AC generator terminal.

Please follow below steps to install the AC connector.

1. Select the suitable cable. Remove the insulating layer of the AC output cable using a wire stripper. Insert the cable with stripped insulation into the tubular terminal and crimp it with a suitable tool and in accordance with the following illustration:

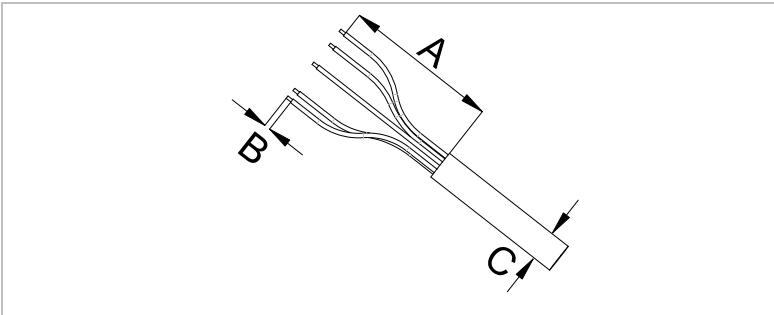

Figure 5-17 Wire stripping requirement

A = 95~100mm

B = 20~25mm

C = 20~30mm

Copper wire: 20...25mm²

⚠ CAUTION

- ▶ Ensure that the cable jacket is inside the connector.
- ▶ Insert the exposed core wires completely into the holes.



- ▶ Connect the AC output cable securely. Otherwise, the device may fail to operate properly or the AC connector may be damaged.
- ▶ Ensure that the cable is not twisted.

2. Assemble the AC connector according to the following diagram. The connection method for the AC connectors of the Grid port, Backup port, and Generator port is the same.

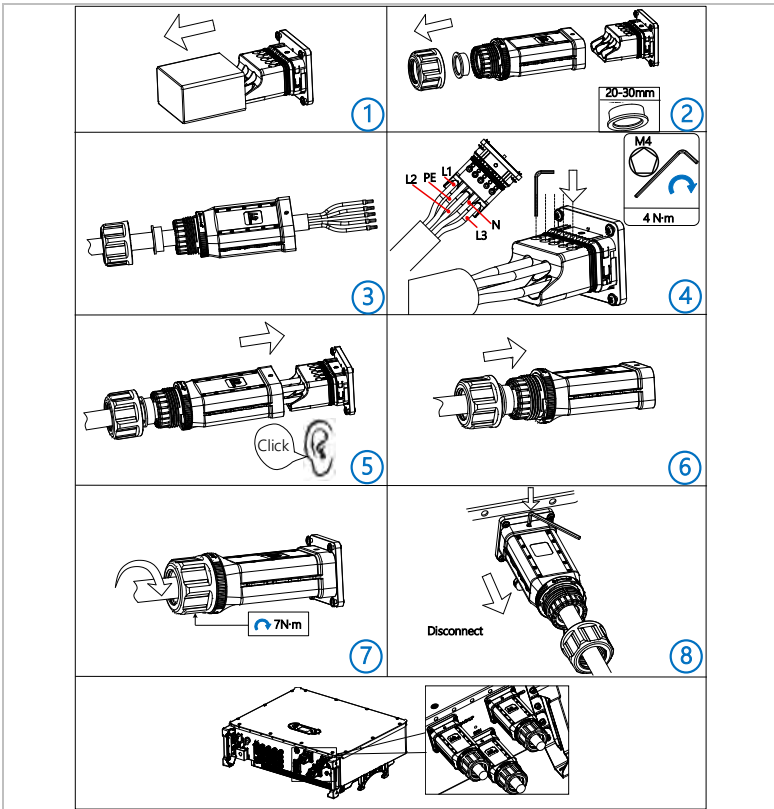

Figure 5-18 AC connection

CAUTION

- ▶ Strip the insulation layers of the AC output power cable by the recommended length (20–25 mm) to ensure that the cable conductors are completely inside the conductor insertion points and no insulation layer is pressed into the conductor insertion points. Tighten the cable conductors to a torque of 4 Nm. Otherwise, the device may fail to run properly or be damaged during operation.

5.10 Communication interfaces

The positions of the communications interfaces of the AZZURRO 3PH HYD 30000...60000 ZSR are displayed below:

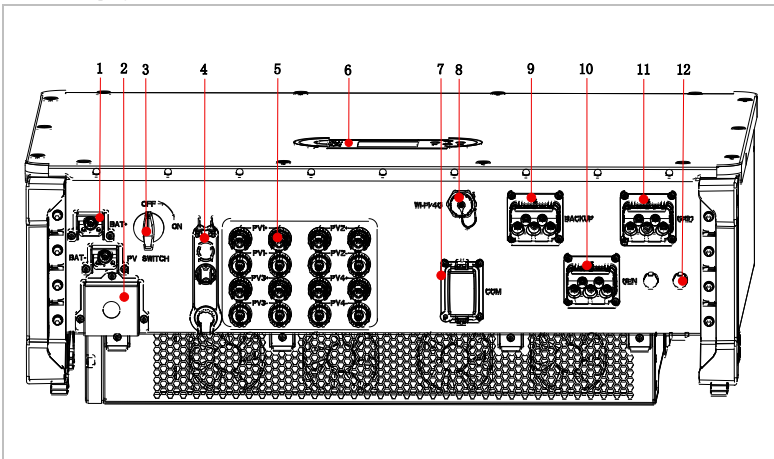

Figure 5-19 AZZURRO 3PH HYD 30000...60000 ZSR interfaces

No.	Connection	Function
7	COM	Multi-functional communication ports including parallel, Ethernet, Meter/CT, DRMS, BMS, dry contact, etc.
8	Wi-Fi /Ethernet/4G	USB port for firmware upgrade and safety parameter import; Port to connect Stick Logger.

5.1.0.1 Multifunctional Communication Port Definition

The RJ45 connector for the Multifunctional Communication Port follows the T568B standard. Please refer to the following table for the specific PIN assignments.

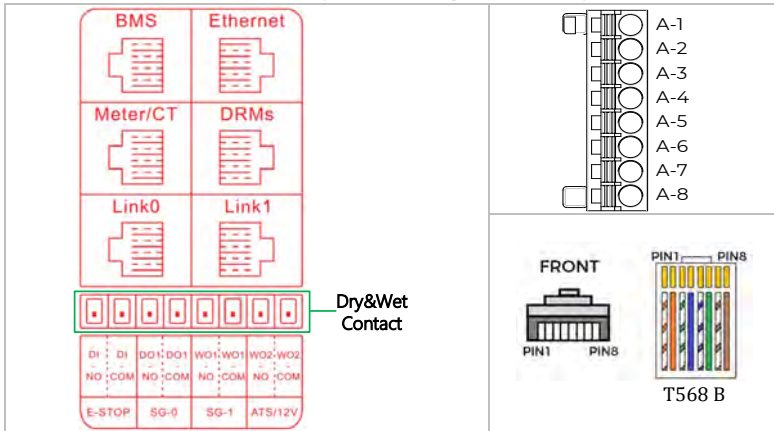

Figure 5-20 COM interfaces

BMS

PIN	Colour	Connection	Function
1	Orange White	/	/
2	Orange	/	/
3	Green White	CAN1_H	CAN1_H
4	Blue	CAN2_H	CAN2_H
5	Blue White	CAN2_L	CAN2_L
6	Green	CAN1_L	CAN1_L
7	Brown White	RES+	RES+
8	Brown	RES-	RES-

Meter/CT

PIN	Colour	Connection	Function
1	Orange White	Meter-RS485 A	Meter-RS485 differential signal+
2	Orange	Meter-RS485 B	Meter-RS485 differential signal-
3	Green White	CT A+	CT A differential signal+
4	Blue	CT B+	CT B differential signal+
5	Blue White	CT B-	CT B differential signal-
6	Green	CT A-	CT A differential signal-
7	Brown White	CT C+	CT C differential signal+
8	Brown	CT C-	CT C differential signal-

DRMs

PIN	Colour	Connection	Function
1	Orange White	DRM1/5	DRM1/5
2	Orange	DRM2/6	DRM2/6
3	Green White	DRM3/7	DRM3/7
4	Blue	DRM4/8	DRM4/8
5	Blue White	GND	GND
6	Green	DRM0	DRM0
7	Brown White	/	Internally shorted
8	Brown	/	



Link0&Link1

PIN	Ports	Connection	Function
1	Orange White	Upper computer- RS485 A	Upper computer - RS485 differential signal+
2	Orange	Upper computer- RS485 B	Upper computer - RS485 differential signal-
3	Green White	GND_S	GND_S
4	Blue	CAN-H	CAN-H
5	Blue White	CAN-L	CAN-L
6	Green	IN_SYN0	IN_SYN0
7	Brown White	IN_SYN1	IN_SYN1
8	Brown	IN_SYN2	IN_SYN2

Dry & Wet Contact

PIN	Ports	Connection	Function
1	E-STOP	DI NO	Use for Emergency STOP (If ENABLE) DI NO connects with DI COM: RUN DI NO disconnects with DI COM: STOP
2		DI GND	
3	SG-0	DO1 NO	It can be controlled through the LCD.
4		DO1 COM	
5	SG-1	WO1 NO	
6		WO1 GND	
7	ATS/12V	WO2 NO	It can be controlled through the LCD.
8		WO2 GND	





- ▶ Link port for Ethernet: Ethernet for TCP/IP Modbus
- ▶ Link port for Parallel: link0 and link1.
- ▶ The voltage of the Dry & Wet Contact port must not exceed 28V and must be less than 1A. Otherwise, it may damage the hardware circuit and cause related functions to fail.

5.10.2 Multifunctional Communication Cable Production

1. Prepare a RJ45 cable (accessories of battery)

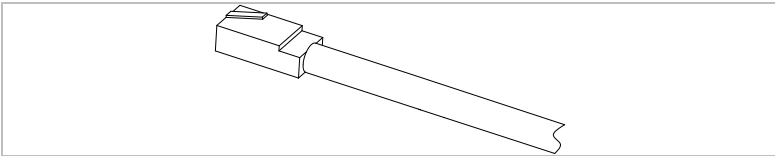

Figure 5-21 COM connector production (a)

1. Remove the rubber plugs from the COM connector and pull out the appropriate number of plugs according to the desired function. Insert the cable into the hole of the plug:

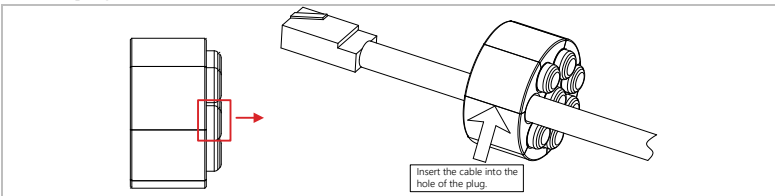

Figure 5-22 COM connector production (b)

2. After removing the stopper, pass the cable through the connector gland, connector clip and connector through-hole.

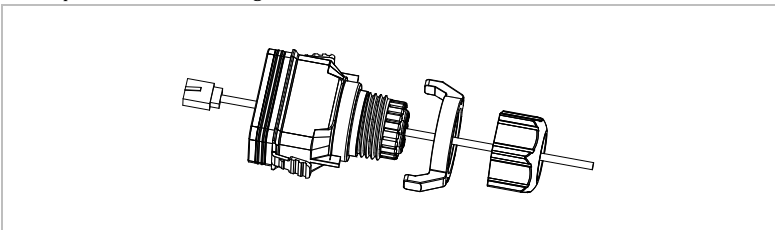

Figure 5-23 COM connector production (c)



3. After assembling the connectors in order, insert the RJ45 connector into the corresponding terminal of the COM port:

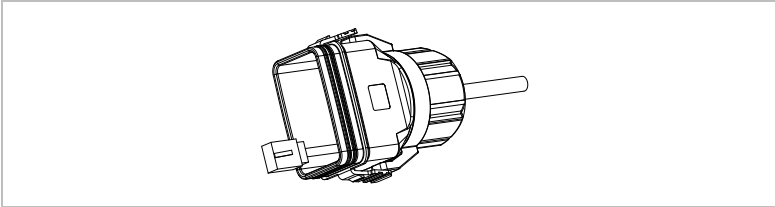

Figure 5-24 COM connector production (d)

4. Locking the connector housing to the inverter COM port:

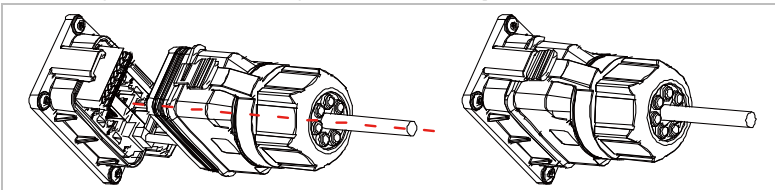

Figure 5-25 COM connector production (e)

5.10.3 Smart meter/CT

The integrated energy management functions integrated of the AZZURRO 3PH HYD 30000...60000 ZSR require to measure the power flow at the point of grid interconnection. There are different system configurations possible. It can be measured using directly connected using CTs or Meter + CTs.

The PIN assignment for the connection between inverter and CTs or smart meter can be found in the table below.

Inverter COM Port Pin	Function	Meter Pin
Meter/CT PIN1	Meter-RS485 A	Pin 24
Meter/CT PIN2	Meter-RS485 B	Pin 25

Inverter COM Port Pin	Function	CT's Pin
Meter/CT PIN3	CT A differential signal+	CT A+
Meter/CT PIN4	CT B differential signal+	CT B+
Meter/CT PIN5	CT B differential signal-	CT B-
Meter/CT PIN6	CT A differential signal-	CT A-
Meter/CT PIN7	CT C differential signal+	CT C+
Meter/CT PIN8	CT C differential signal-	CT C-

- ▶ The Smart meter shows a positive power value for feed-in to the grid, and a negative value for energy purchase from the grid.
- ▶ Use the shielded twisted pair cable (the shield must be grounded on one of the two sides)
- ▶ The copper outer diameter should be more than 0.5 mm².
- ▶ Keep away from power cables or other electric fields.
- ▶ Use termination resistors at the ends of the RS485 line to improve signal quality.

System A: direct measurement with CT's

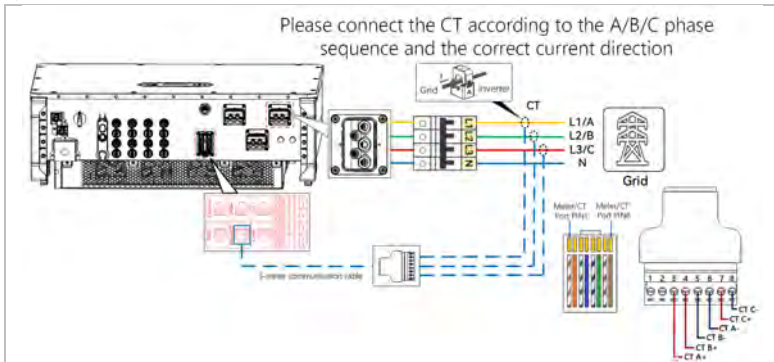

Figure 5-26 CT's Connection



Measurement of photovoltaic production via three-phase meter

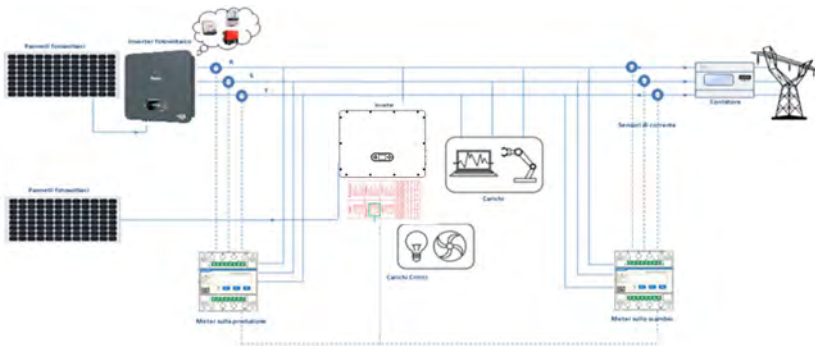

Figure 5-27a connection and smart meter with CTs on exchange and production (taking CHINT smart meter as an example)

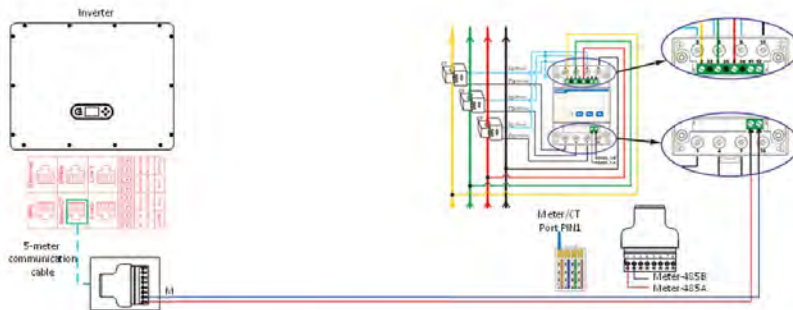

Figure 5-27b connection and smart meter with CTs on exchange and production (taking CHINT smart meter as an example)





Three-phase DTSU Meter parameter configuration

After you have successfully connected the wiring, you need to set the correct parameters from the Meter display.



1. Press to:
 - “Confirm”
 - “Move the cursor”
(for entering values)
2. Press to “go back”
3. Press to “slide”

Figure 5 27c – Meter legend

Three-phase DTSU Meter configuration to exchange

To view the device in read mode on the exchange you need to enter the settings menu, as indicated below:

1. Press SET the inscription will appear CODE



2. Press SET, the inscription will appear “600”:



3. Write the figure “701”:
 - a. From the first screen where the number “600” appears, press the “ ” key once to enter the number “601”.
 - b. Press “SET” twice to move the cursor to the left to highlight “601”;
 - c. Press the “ ” key once more until you enter the number “701” (701 is the access code to the settings).

Note: In case of error press "ESC" and then again "SET" to reset the required code.



1. Confirm by pressing SET until you enter the settings menu.
2. Enter the following menus and set the parameters indicated:
 - D. CT:
 - I. Press SET to enter the menu
 - II. Write "40":
 1. From the first screen where the number "1" appears, press " " repeatedly until the number "10" appears.
 2. Press "SET" once to move the cursor to the left to highlight "10"
 3. Press the button "→" several times until you enter the number "40"

Note: In the event of an error, press "SET" until the number of thousands is highlighted and then press " " until only the number "1" appears; at this point repeat the procedure described above.



III. Press "ESC" to confirm "→" to scroll to the next setting

- E. ADDRESS:
 - IV. Leave the address 01 (set by default) in this way the inverter will assign as power relative to the exchange the data sent by the meter.

Three-phase DTSU meter configuration on exchange and production

To view the device in read mode on the exchange you need to enter the settings menu, as indicated below:

1. Press SET the inscription will appear CODE



2. Press SET, the inscription will appear "600":



3. Write the figure "701":
 - a. From the first screen where the number "600" appears, press the key once to enter the number "601".
 - b. Press "SET" twice to move the cursor to the left to highlight "601";
 - c. Press the " " key once more until you enter the number "701" (701 is the access code to the settings).

Note: In case of error press "ESC" and then again "SET" to reset the required code.



4. Confirm by pressing SET until you enter the settings menu.
5. Enter the following menus and set the parameters indicated:
 - d. CT:
 - I. Press SET to enter the menu
 - II. Write "40":
 - i. From the first screen where the number "1" appears, press " " repeatedly until the number "10" appears.
 - ii. Press "SET" once to move the cursor to the left to highlight "10"
 - iii. Press the button "→" several times until you enter the number "40"

Note: In the event of an error, press "SET" until the number of thousands is highlighted and then press " " until only the number "1" appears;

at this point repeat the procedure described above.



III. Press "ESC" to confirm "→" to scroll to the next setting

e. ADDRESS:

I. Press SET for enter Menù:

II. Write "02" (press one time "→" from the screen "01").

With address 02 the inverter will assign the data sent by the meter as relative power to the production. They can be set up to a maximum of 3 Meters for production (Addresses 02 03 04).



III. Press "ESC" to confirm.

Three-phase DTSU meter verification at exchange

To carry out such verification it is necessary:

- Turn on the hybrid inverter only in alternation and turn off any other source of photovoltaic production (if any);
- Turn on carichi greater than 1kw for each of the three phases of the plant;

Bring yourself in front of the Meter and using the keys " " to scroll between the entries and "ESC" to go back, it must be verified that:

1. The Power Factor values for each phase Fa, Fb, and Fc (voltage to current offset), are between 0.8-1.0. In case of a lower value, the sensor must be moved in one of the other two phases until that value is between 0.8-1.0.

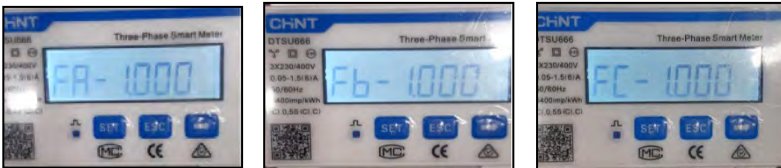

2. The Power Pa, Pb and Pc must be:
 - Greater than 1 kW.
 - In line with household consumption.
 - The sign in front of each negative value (-).

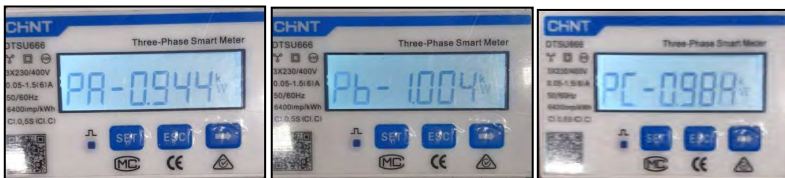

3. Turn on the PV inverter via rotary switch on ON and batteries, verify that the total power value P_t is in line with the value shown on the inverter display

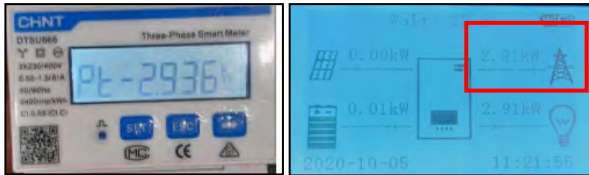

Three-phase DTSU Meter Verification on Production

In case of meter on the production it is necessary to repeat the previous operations:

1. Switch off the hybrid inverter and leave on only the pure photovoltaic;
2. Making pure photovoltaic go into production;
3. Power factor verification as described in the previous case;
4. The power sign P_a , P_b , and P_c must be in agreement;
5. Turn on Hybrid Inverter, verify that the total power value P_t photovoltaic is in line with the value shown on the inverter display.

5.10.4 Parallel Port

In systems with multiple inverters, you can connect the devices in a Master/Slave configuration. In this configuration, only one energy meter is connected to the Master inverter for the system control.

- ▶ In the **off-grid mode**, a maximum of 3 inverters can be connected in parallel.
- ▶ In the **on-grid mode**, a maximum of 6 inverters can be connected in parallel.
- ▶ In systems with multiple inverters, The parallel communication line shall not exceed 10 m.

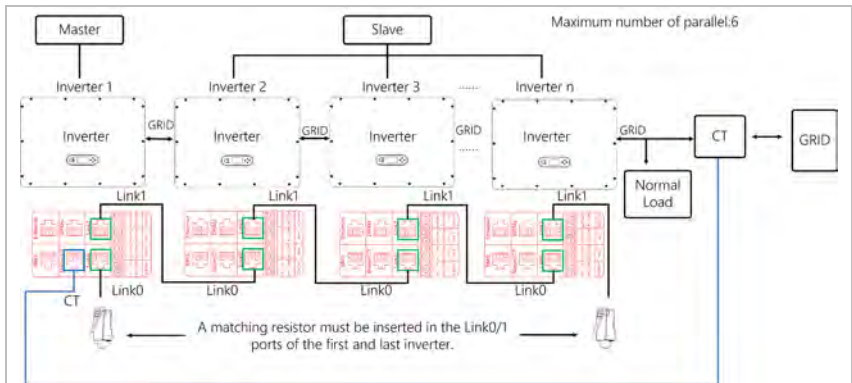

Figure 5-28 parallel system (on-grid mode)

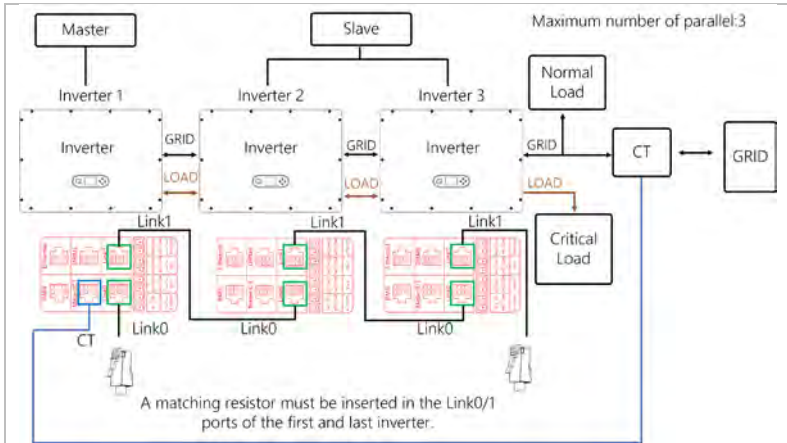
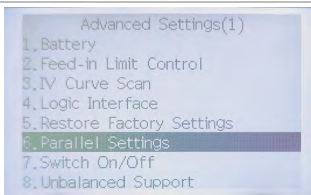

Figure 5-29 parallel system (off-grid mode)

Parallel setting



Select Advanced Settings



Select Parallel Settings



Enter the password 0715.

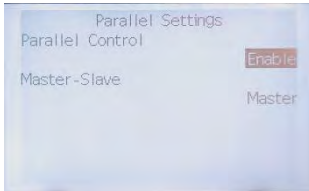

Master inverter

Select Inverter 1. Switch the parallel control from disabled to enabled. The default state of inverter 1 is that it is in the Master mode.



Slave inverters

Configure inverters 2 to n in sequence based on the number of parallel units. The maximum number of parallel units for three phase AZZURRO 3PH HYD 30000...60000 ZSR inverter is six.

Setting parallel address from 2 to 6 for slave inverter.

- ▶ In the parallel operation mode, emergency power supply, generator mode and unbalanced support need to be turned off remotely first. The settings for the slave units must be made on the master machine after the remote shutdown.
- ▶ Be careful when the parallel inverters are connected, then the communication cable should not be bundled with the power cable (GRID - BACKUP) in one cable channel or to be very close, it may cause abnormal faults in the parallel system. It is preferable to pass the communications cables in a separate cable channel.

5.10.5 BMS connection

For batteries, you need to connect either the CAN Bus with the battery management system (The communication cable is included in the battery accessory package).

The inverter will use the CAN Bus according to the battery selection in the inverter's menu.

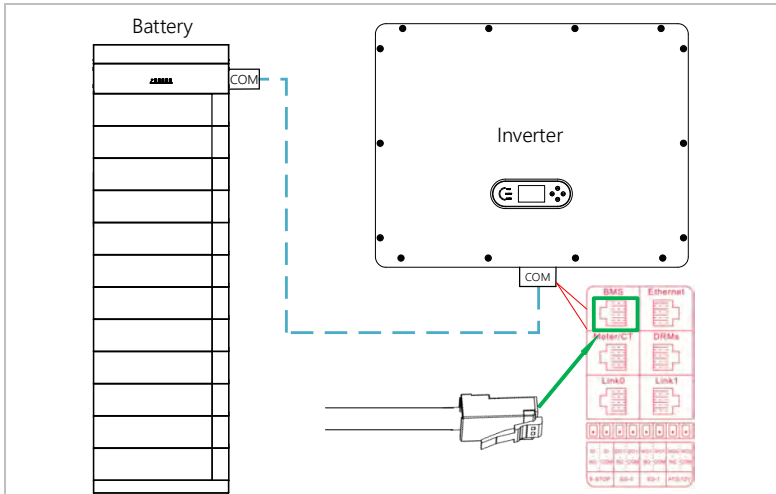

Figure 5-30 BMS Connection

5.10.6 DRMs/Logic interface

The DRMs/Logic interface is used to control the inverters feed-in or purchases power by external signals, usually provided from grid operators with ripple control receivers or other means. The DRM0 can be used for a switch off signal from external grid protection devices.

The logical interface pins are defined according to the requirements of different standards. Please connect according to the safety requirements of your country (see below for a brief description of the safety requirements).

First, connect the DRMs port cable in the COM port cable set to the control unit in accordance with the wire sequence required by the safety regulations:

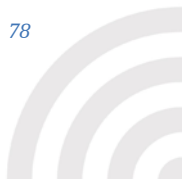

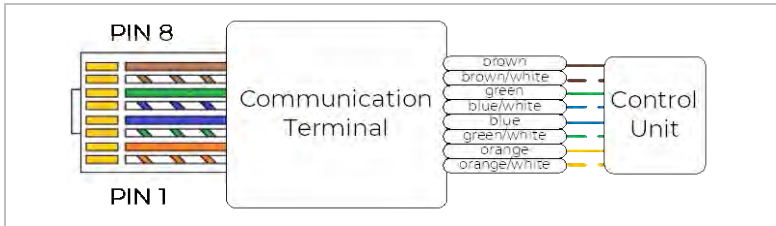

Figure 5-31 DRMs Connection(a)

Connect the RJ45 terminal on the other end of the COM connector to the DRMs port:

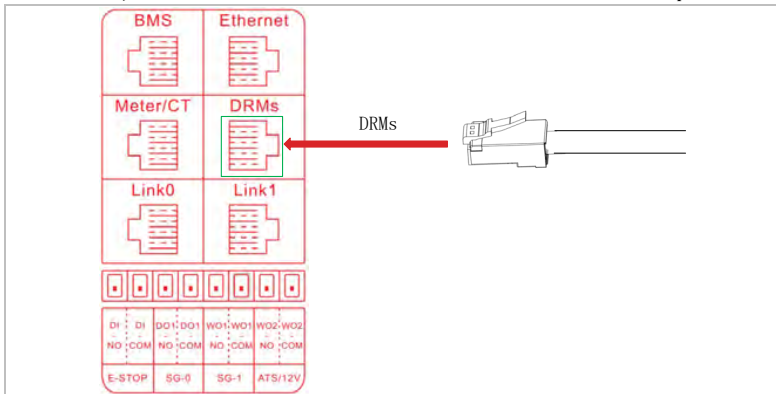

Figure 5-32 DRMs Connection(b)

DRMs for AS/NZS 4777.2:2015 and AS/NZS 4777.2:2020

Also known as Inverter Demand Response Modes (DRMs).

The inverter recognizes all supported Demand Response commands and initiates the reaction within two seconds. The inverter will continue to respond while the mode remains asserted.

Pin	Colour	Function
1	orange/white	DRM1/5
2	orange	DRM2/6



3	green/white	DRM3/7
4	blue	DRM4/8
5	blue/white	RefGen
6	green	DRM0
7	brown/white	Internally shorted
8	brown	

Method of asserting demand response modes:

Mode	RJ45 socket Asserted by shorting pins:		Real current limit (referenced to inverter rated per phase current)
	5	6	
DRM0	5	6	0
DRM1	1	6	Import=0
DRM2	2	6	Import<50%
DRM3	3	6	Import<75%
DRM4	4	6	Not limited
DRM5	1	5	Generate=0
DRM6	2	5	Generate<50%
DRM7	3	5	Generate<75%
DRM8	4	5	Not limited

Logic interface for VDE-AR-N 4105:2018-11



This function serves to control and/or limit the output power of the inverter. The inverter can be connected to a radio ripple control receiver in order to dynamically limit the output power of all inverters within the system.

RCR: Ripple control receiver (RCR) is an interface between a PV system and power grid company.

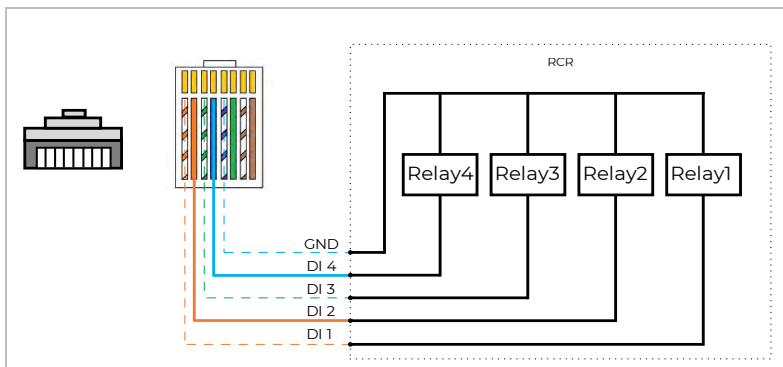

Figure 5-33 DRMs Connection(c)

The inverter is preconfigured on the following power levels:

Pin	Name	Parameter	Preset Power Value*
1	DI 1	Relay1 engaged	0%
2	DI 2	Relay2 engaged	30%
3	DI 3	Relay3 engaged	60%
4	DI 4	Relay4 engaged	100%
5	GND	Internal signal	/

*) When using this function on your own, make sure that the normally open relay is disconnected before use, and provide the drive signal for the relay on your own.

*) Priority: DI 1 > DI 2 > DI 3 > DI 4



Logic interface for EN50549-1:2019

The active power output can be ended within five seconds following a command to the input interface.

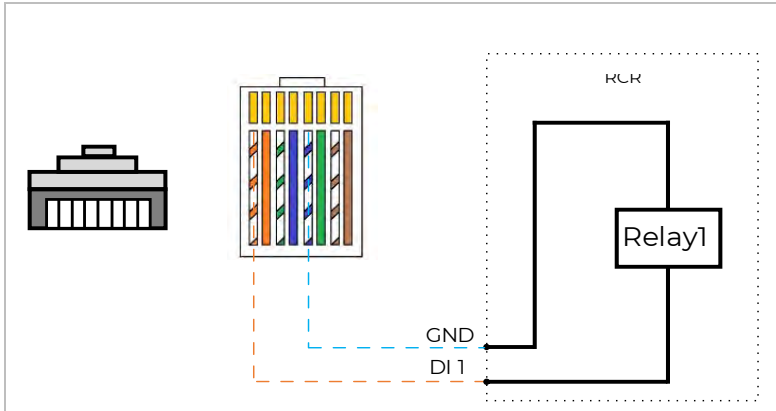

Figure 5-34 DRM connection(d)

Functional description of the terminal

Pin	Name	Inverter	Preset Power Value*
1	DI 1	Relay1 engaged	0%
5	GND	Internal signal	/



5.10.7 Emergency STOP

AZZURRO 3PH HYD 30000...60000 ZSR has Emergency STOP function. To enable this function, please refer to the following steps:

A. Connection interfaces

DI NO and DI COM are used for Emergency STOP.

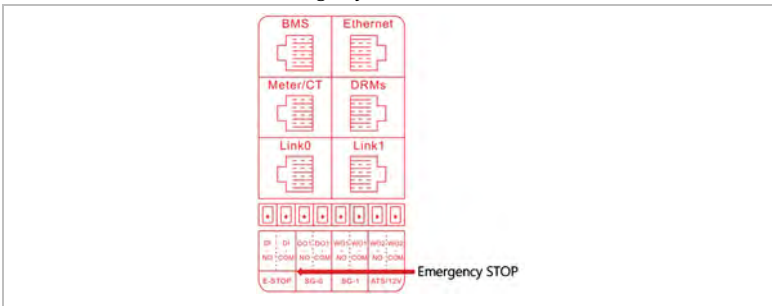
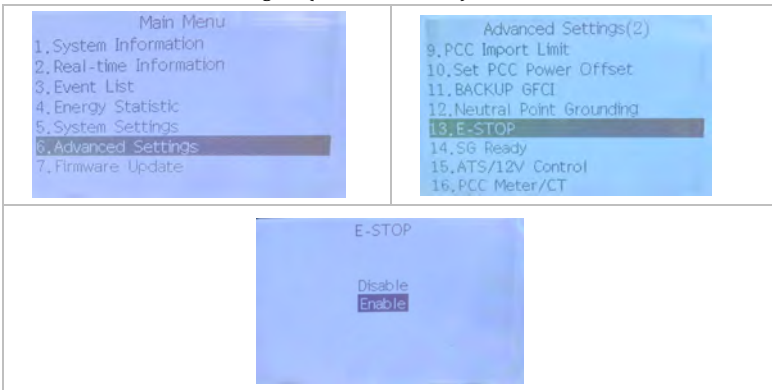

Figure 5-35 Emergency STOP connection(a)

B. Function setting

Enable the function via LCD:

Main Menu → Advanced Settings → (Passwords: 0715) → E-STOP → Enable



DI NO connects with DI GND: RUN

DI NO disconnects with DI GND: STOP



ZUCCHETTI
Centro Sistemi





C. Application example

Normal work:

Pin1(DI NO) is connected with Pin2(DI COM) by the button.

Emergency STOP :

PUSH the button. Pin1(DI NO) disconnects with Pin2(DI COM). The inverter will stop working.

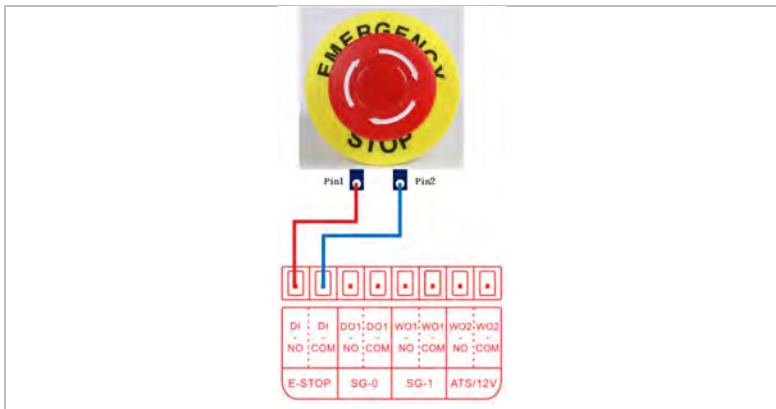

Figure 5-36 Emergency STOP connection(b)

5.11 Feed-in limit function

The feed-in limit function can be used to limit the power fed back into the grid. For this function, a power measurement device must be installed according to system A, B, or C.

Feed-in limit: The sum of the feeding-in phases must not exceed the set power limitation value. The power of phases drawing power from the grid is disregarded here.

3-phase limit: The sum of the feed-in power of all three phases must not exceed the set power limit value. This setting is suitable for balancing metering, as is common in Germany, for example.

- ▶ For the 3-phase limit setting, the current sensors must be correctly assigned to phases L1, L2 and L3.
- ▶ If communication with the smart meter is interrupted, the inverter limits its output power to the set power limit value.

5.12 System monitoring

ZCS monitoring				
Product code	Product photo	APP monitoring	Portal monitoring	Possibility to send commands and to update the inverter remotely in case of technical support
ZSM-WIFI				
ZSM-ETH				
ZSM-4G				

The AZZURRO 3PH HYD 30000...60000 ZSR inverters provide various communication methods for the system monitoring:

RS485, Wi-Fi stick, Ethernet stick or 4G stick.

5.12.1 RS485

You can connect RS485-linked devices to your PC or a data logger via an RS485 USB adapter.

- ▶ The RS485 line may not be any longer than 1000 m.
- ▶ Assign each inverter its own Modbus address (1 to 31) via the LCD display.





5.12.2 Wi-Fi/Ethernet/4G

When you have installed the stick logger, the inverters can directly upload your operating, energy and alarm data in the AZZURRO monitoring portal/APP.

5.13 Installation of the Wi-Fi

1. Remove the protective cap from the USB interface.
2. Install the Wi-Fi/Ethernet stick.
3. Tighten the connecting nut.

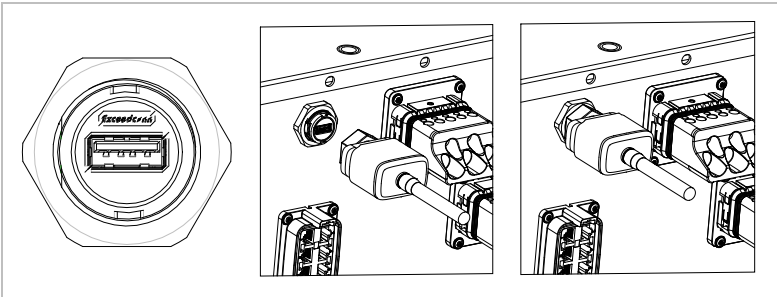

Figure 5-37 Install Wi-Fi stick

5.13.1 Configuration of the WiFi stick via the web browser

Preparation: The WiFi stick is installed in accordance with the previous section and the Zucchetti Centro Sistemi Spa inverter must be in operation.

- ▶ WiFi network need to support 2.4 GHz mode. WiFi stick logger doesn't support 5 GHz network!
- ▶ The stick loggers are using outgoing TCP port 10000. In case your router has limited the ports please open it for the stick logger.

Configuration of the Wi-Fi adapter requires the presence of a Wi-Fi network near the inverter in order to achieve stable transmission of data from the inverter adapter to the Wi-Fi modem.

Tools required for configuration:

1) Smartphone, PC or tablet

Go to front of the inverter and search for the Wi-Fi network using a smartphone, PC or tablet, making sure that the signal from the home Wi-Fi network reaches the place where the inverter is installed.

If the Wi-Fi signal is present at the location where the inverter is installed, the configuration procedure can begin.

If the Wi-Fi signal does not reach the inverter, a system must be installed to amplify the signal and bring it to the installation location.

1) Activate the search for the Wi-Fi networks on your telephone or PC so that all the networks visible by your device are displayed.

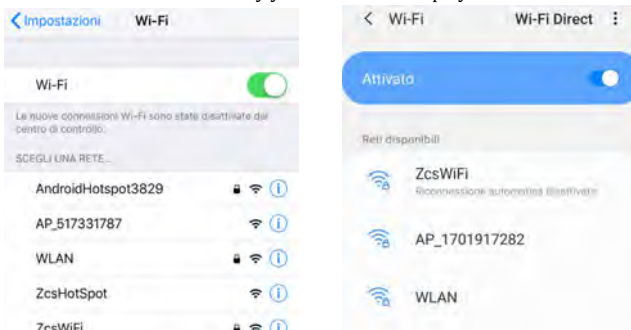

Figure 5-38 - Search for Wi-Fi networks on iOS smartphone (left) and Android smartphone (right)

Note: Disconnect from any Wi-Fi networks to which you are connected by removing automatic access.





Figure 5-39 - Disabling automatic reconnection to a network

- 2) Connect to a Wi-Fi network generated by the inverter's Wi-Fi adapter (i.e. AP_*****, where ***** indicates the serial number of the Wi-Fi adapter shown on the label of the device), which operates as an access point.

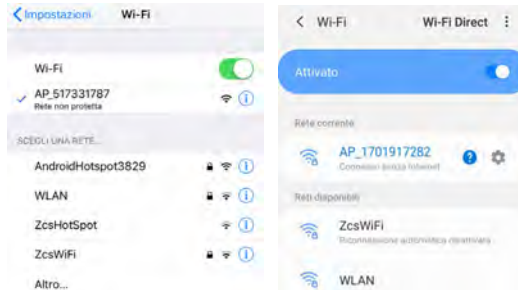

Figure 5-40 - Connection to Access Point for Wi-Fi adapter on iOS smartphone (left) and Android smartphone (right)

- 3) If you are using a second-generation Wi-Fi adapter, you will be prompted for a password to connect to the inverter's Wi-Fi network. Use the password found on the box or on the Wi-Fi adapter.





Figure 5-41 – Password of external Wi-Fi adapter

Note: To ensure that the adapter is connected to the PC or smartphone during the configuration procedure, enable automatic reconnection of the AP_***** network.

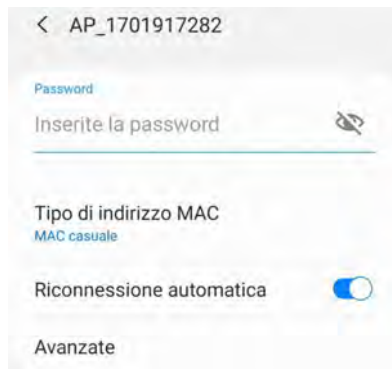

Figure 5-42 – Password entry prompt

Note: the Access Point is not able to provide internet access; confirm to maintain the Wi-Fi connection, even if the internet is not available





Figure 5-43 – Screen indicating that the Internet cannot be accessed

- 4) Open a browser (Google Chrome, Safari, Firefox) and enter the IP address 10.10.100.254 in the address bar at the top of the screen.
In the box that appears, enter “admin” as both the Username and Password.

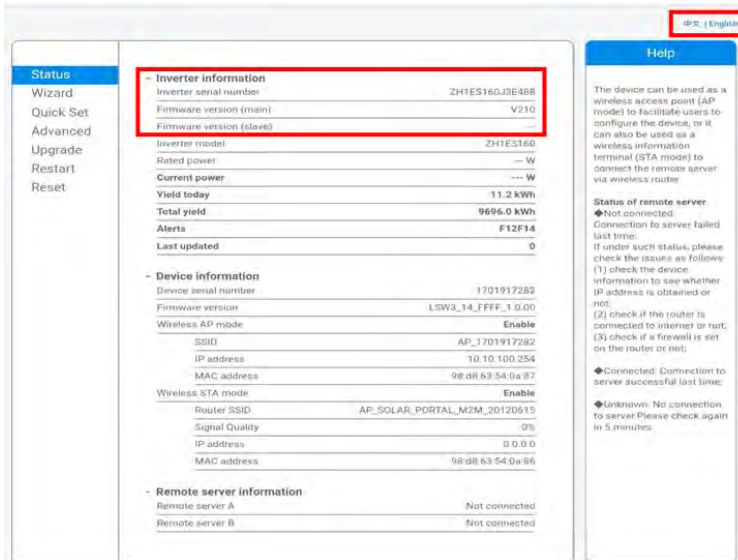

Figure 5-44 – Screen for accessing the web server to configure the Wi-Fi adapter

- 5) The status screen will open, showing the logger information such as the serial number and firmware version.

Check that the Inverter Information fields are filled in with the inverter information.

The language of the page can be changed using the command in the top right-hand corner.



The screenshot shows the status screen of a ZUCCHETTI device. The language dropdown in the top right corner is set to 'EN - English'. The main content is divided into three sections: Inverter information, Device information, and Remote server information. The 'Inverter information' section is highlighted with a red box.

- Inverter information	
Inverter serial number	ZH1ES160JSE466
Firmware version (main)	V210
Firmware version (slave)	---
Inverter model	ZH1ES160
Rated power	--- W
Current power	--- W
Yield today	11.2 kWh
Total yield	9696.0 kWh
Alerts	F12F14
Last updated	0

- Device information	
Device serial number	1701917282
Firmware version	LSW3_14_FFFF_1 0.00
Wireless AP mode	Enable
SSID	AP_1701917282
IP address	10.10.100.254
MAC address	98-d8-63-54-0a-B7
Wireless STA mode	Enable
Router SSID	AP_SOLAR_PORTAL_M2M_20120615
Signal Quality	0%
IP address	0.0.0.0
MAC address	98-d8-63-54-0a-B6

- Remote server information	
Remote server A	Not connected
Remote server B	Not connected

Figure 5-45 - Status screen

- 6) Click on the Wizard setup button in the left-hand column.
- 7) In the new screen that opens, select the Wi-Fi network to which you want to connect the Wi-Fi adapter, making sure that the Received Signal Strength Indicator (RSSI) is greater than 30%. If the network is not visible, press the Refresh button.

Note: check that the signal strength is greater than 30%, if not, bring the router closer or install a repeater or signal amplifier.

Click Next.





Please select your current wireless network:

Site Survey

SSID	BSSID	RSSI/Channel
iPhone di Giacomo	E:25 EF 6C 31 18	100 9
ZcsWiFi	FE:ED:DA:1D:C8:9	96 1
ZcsHotSpot	FC:ED:DA:1D:C8:9	96 1
WLAN	E:EC:DA:1D:C3:9	96 1
ZcsHotSpot	FC:ED:DA:1D:C8:A3:57	11
WLAN	E:EC:DA:1D:C8:A3	57 11
ZcsWiFi	FE:ED:DA:1D:D8:A3	54 11
WLAN	E:EC:DA:1D:C8:8F	45 1
ZcsWiFi	FE:ED:DA:1D:C8:8F	17 1
ZcsHotSpot	FC:ED:DA:1D:C8:8F:00:5	1

★Note: When RSSI of the selected WiFi network is lower than 15%, the connection may be unstable, please select other available network or shorten the distance between the device and router.

Refresh

Add wireless network manually:

Network name (SSID)
(Make sure sensitive)

Encryption method

Encryption algorithm

Next

1 2 3 4

Figure 5-46 – Screen for selecting the available wireless network (1)

- 8) Enter the password of the Wi-Fi network (Wi-Fi modem), clicking on Show Password to make sure it is correct; the password should not contain special characters (&, #, %) and spaces.

Note: During this step, the system is not able to ensure that the password entered is the one actually requested by the modem, therefore please make sure you enter the correct password.

Also check that the box below is set to Enable.

Then click “Next” and wait a few seconds for verification.





Please fill in the following information:

Password (8-64 bytes)
(Note: case sensitive)
 Show Password

Obtain an IP address automatically **Enable** ▾

IP address

Subnet mask

Gateway address

DNS server address

1 2 3 4

Figure 5-46 – Screen for entering the password of the wireless network (2)

- 9) Click “Next” again without ticking any of the options relating to the system security.

Enhance Security

You can enhance your system security by choosing the following methods

Hide AP

Change the encryption mode for AP

Change the user name and password for Web server

1 2 3 4

Figure 5-47 - Screen for setting the security options (3)

- 10) Click “OK”.





Setting complete!

Click OK, the settings will take effect and the system will restart immediately.

If you leave this interface without clicking OK, the settings will be ineffective.



Figure 5-48- Final configuration screen (4)

- 11) At this point, if the configuration of the adapter is successful, the last configuration screen will appear, and the telephone or PC will unpair from the inverter's Wi-Fi network.
- 12) Manually close the web page with the Close key on the PC por remove it from the background of the telephone.

Setting complete! Please close this page manually!

Please login our management portal to monitor and manage your PV system. (Please register an account if you do not have one.)

To re-login the configuration interface, please make sure that your computer or smart phone

connecting to wifi.

Figure 5-49 - Successful configuration screen

5.13.2 Verification

To verify the correct configuration, connect to it again and access the status page. Check the following information:

- a. Wireless STA mode
 - i. Router SSID > Router name
 - ii. Signal Quality > other than 0%
 - iii. IP address > other than 0.0.0.0
- b. Remote server information
 - i. Remote server A > Connected

Wireless STA mode	Enable
Router SSID	iPhone di Giacomo
Signal Quality	0%
IP address	0.0.0.0
MAC address	98:d8:63:54:0a:86
Remote server information	
Remote server A:	Not connected

Figure 5-50 – Status screen

Status of LEDs present on the adapter

- 1) Initial status:
 NET (left LED): off
 COM (central LED): steady on
 READY (right LED): flashing on



Figure 5-51 - Initial status of LEDs



- 2) Final status:
NET (left LED): steady on
COM (central LED): steady on
READY (right LED): flashing on



Figure 5-52 - Final status of LEDs

If the NET LED does not light up or if the Remote Server A option in the Status page still shows “Not Connected”, the configuration was not successful, i.e. the wrong router password was entered or the device was disconnected during connection.

It is necessary to reset the adapter:

- ✓ Press the Reset button for 10 seconds and release
- ✓ After a few seconds, the LEDs will turn off and READY will start to flash quickly
- ✓ The adapter has now returned to its initial state. At this point, the configuration procedure can be repeated again.

The adapter can only be reset when the inverter is switched on.





Figure 5-52 – Reset button on the Wi-Fi adapter

5.13.3 Troubleshooting

Status of LEDs present on the adapter

- 1) Irregular communication with inverter
 NET (left LED): steady on
 COM (central LED): off
 READY (right LED): flashing on



Figure 5-52 - Irregular communication status between inverter and Wi-Fi

- ✓ Check the Modbus address set on the inverter:

Enter the main menu with the ESC key (first key on the left), go to System Info and press ENTER to enter the submenu. Scroll down to the Modbus address parameter and make sure it is set to 01 (and in any case, other than 00).

If the value is not 01, go to “Settings” (basic settings for hybrid inverters) and enter the Modbus Address menu where the 01 value can be set.

- ✓ Check that the Wi-Fi adapter is correctly and securely connected to the inverter, making sure to tighten the two cross-head screws provided.

- ✓ Check that the Wi-Fi symbol is present in the top right-hand corner of the inverter's display (steady or flashing).



Figure 5-53 – Icons on the display of LITE single-phase inverters (left) and three-phase or hybrid inverters (right)

Restart the adapter:

- ✓ Press the reset button for 5 seconds and release
- ✓ After a few seconds, the LEDs will turn off and will start to flash quickly
- ✓ The adapter will now be reset without having lost the configuration with the router

- 2) Irregular communication with remote server
 NET (left LED): off
 COM (central LED): on
 READY (right LED): flashing on



Figure 5-54 - Irregular communication status between Wi-Fi and remote server

- ✓ Check that the configuration procedure has been carried out correctly and that the correct network password has been entered.
- ✓ When searching for the Wi-Fi network using a smartphone or PC, make sure that the Wi-Fi signal is strong enough (a minimum RSSI signal strength of 30% is required)



during configuration). If necessary, increase it by using a network extender or a router dedicated to inverter monitoring.

- ✓ Check that the router has access to the network and that the connection is stable; check that a PC or smartphone can access the Internet
- ✓ Check that port 80 of the router is open and enabled to send data
- ✓ Reset the adapter as described in the previous section

If, at the end of the previous checks and subsequent configuration, Remote server A is still “Not Connected” or the NET LED is off, there may be a transmission problem at the home network level and, more specifically, that data between the router and server is not being transmitted correctly. In this case, it is advisable to carry out checks at the router level in order to ensure that there are no obstructions on the output of data packets to our server.

To make sure that the problem lies in the home router and to exclude problems with the Wi-Fi adapter, configure the adapter using the Wi-Fi hotspot function on your smartphone as a reference wireless network.

Using an Android mobile phone as a modem

- a) Check that the 3G/LTE connection is active on your smartphone. Go to the Settings menu of the operating system (the gear icon on the screen with a list of all the apps installed on the phone), select “Other” from the Wireless and networks menu and make sure that the Network type is set to 3G/4G/5G.
- b) In the Android settings menu, go to Wireless & networks > Other. Select Mobile Hotspot/Tethering, and then enable the Wi-Fi mobile hotspot option; wait a few seconds for the wireless network to be created. To change the name of the wireless network (SSID) or your password, select Configure Wi-Fi hotspot.



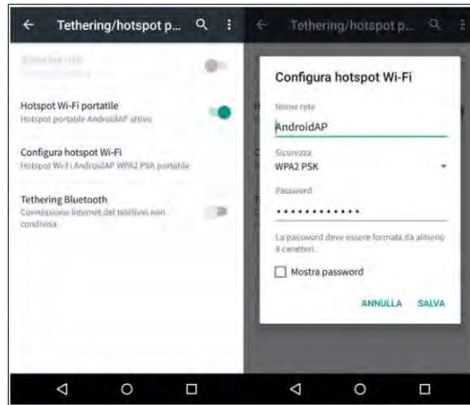

Figure 5-55 - Configuration of an Android smartphone as a hotspot router

Using an iPhone as a modem

- a) In order to share the iPhone connection, verify that the 3G/LTE network is active by going to Settings > Mobile Phone, and making sure that the "Voice and data" option is set to 5G, 4G or 3G. To enter the iOS settings menu, click the grey gear icon on the home screen of your phone.
- b) Go to the Settings menu > Personal Hotspot and turn on the Personal Hotspot option. The hotspot is now enabled. To change the password of the Wi-Fi network, select Wi-Fi password from the personal hotspot menu.

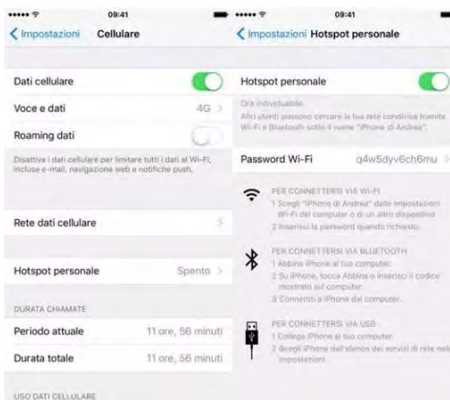

Figure 5-56 - Configuration of an iOS smartphone as a hotspot router

At this point, it is necessary to re-configure the Wi-Fi adapter using a PC or smartphone other than the one used as a modem.

During this procedure, when asked to select the Wi-Fi network, choose the one activated by the smartphone and then enter the password associated with it (which can be changed from the personal hotspot settings). If at the end of configuration, “Connected” appears next to “Remote Server A”, then the problem is with the home router.

It is therefore advisable to check the brand and model of the home router you are trying to connect to the Wi-Fi adapter; some router brands may have closed communication ports. In this case, contact the customer service of the router's manufacturer and ask them to open port 80 (direct from the network to external users).





5.13.4 Setting up the Wi-Fi stick with the app **AZZURRO OPERATORS**

Mobile operating system requirements, minimum version Android 7.0; iOS 14.0.

1. ① Android phone users: search for "Azzurro Operators" in the Android app market (Snap Pea, Baidu, etc.), download and install.
2. ② You can also download "Azzurro Operators " by directly scanning the QR code below or taking a screenshot.



Registration

To access the Azure operators APP there are 2 ways:

1. If you already have a Azzurro System account or Azzurro Operators account you can log in using the usual Email and Password:



WiFi Stick Logger Synchronization

Access the Stick Logger section.

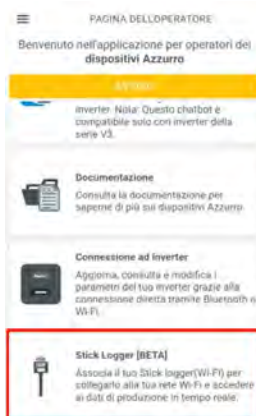

Enter the serial number and password shown on the antenna label, or use the “Scan barcode” function to scan the barcode located on the bottom side of the Stick Logger.

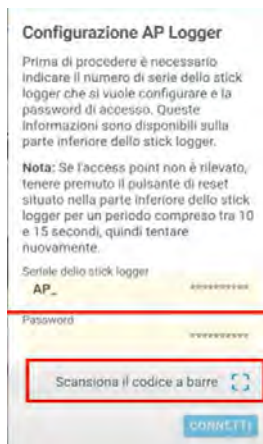

From the list of available WiFi networks, select the network you want to connect the antenna to (in the example shown: ZCS Azzurro WiFi).

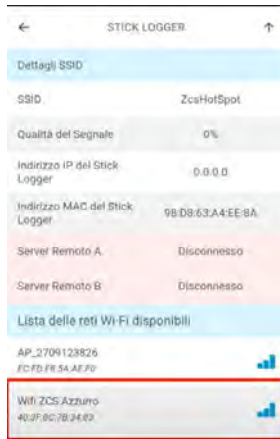

Enter the password of the selected WiFi network and press Save.

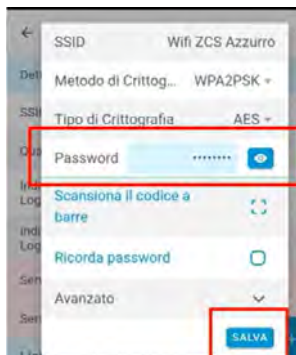

Dopo avere eseguito queste operazioni attendere alcuni minuti per permettere allo stick logger
After completing these steps, wait a few minutes to allow the Stick Logger to reboot and establish the connection.





Reconnect to the Stick Logger: here you can view the device status, connection details, and signal quality.

Dettagli SSID	
SSID	Wifi ZCS Azzurro
Qualità del Segnale	96%
Indirizzo IP del Stick Logger	192.168.1.104
Indirizzo MAC del Stick Logger	98:D8:63:A4:EE:8A
Server Remoto A	Connesso
Server Remoto B	Disconnesso

You can now create the system using the Azzurro System App and/or the Azzurro Portal.

Wi-Fi stick status

The LEDs on the Wi-Fi stick provide information regarding the status:

LED	Status	Description
NET	Communication with the router	On: Connection to server successful
		Flashing (1 sec.): Connection to router successful
		Flashing (0.1 sec.): WPS mode active
		Off: No connection to router
COM	Communication with inverter	Flashing (1 sec.): Communication with inverter
		On: Logger connected to inverter
		Off: No connection to inverter
READY	Logger status	Flashing (1 sec.): Normal status
		Flashing (0.1 sec.): Reset running
		Off: Error status





Reset button

Keystroke	Description
1 sec.	WPS mode
5 sec.	Restart
10 sec.	Restart (reset)

5.13.5 Setting up the Ethernet stick

The Ethernet stick is delivered with DHCP as standard, so it automatically gets an IP address from the router.

If you wish to set up a fixed IP address, connect a PC to the Ethernet stick and open the configuration page via the web address **10.10.100.254**.

Installation

Installation must be carried out for all inverters compatible with the adapter. However, the procedure is quicker and easier as there is no need to open the front cover of the inverter.

Proper operation of the device requires the presence of a modem correctly connected to the network and in operation in order to achieve stable data transmission from the inverter to the server.

In order to monitor the inverter, the RS485 communication address must be set to 01 directly from the display.

Installation tools:

- Cross screwdriver
- Ethernet adapter
- Shielded network (Cat. 5 or Cat. 6) crimped with RJ45 connectors





- 1) Switch off the inverter following the procedure described in this manual.
- 2) Remove the cover for accessing the Wi-Fi/Eth connector on the bottom of the inverter by unscrewing the two cross-head screws (a), or by unscrewing the cover (b), depending on the inverter model, as shown in the figure.

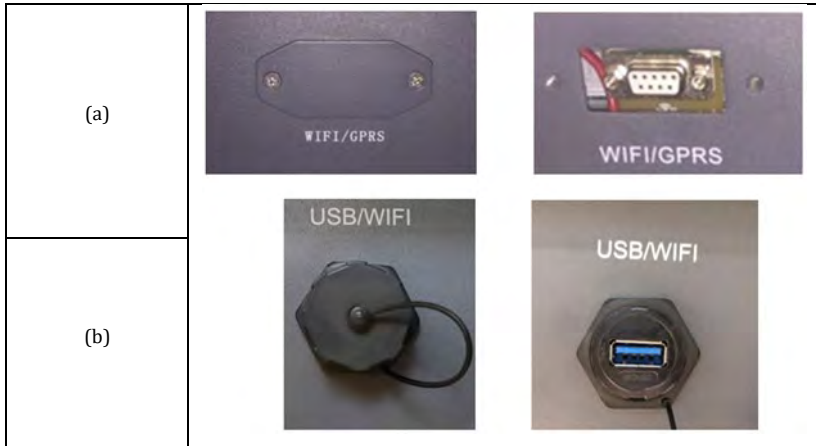

- 3) Remove the ring nut and the waterproof cable gland from the adapter to allow the network cable to pass through; then insert the network cable network into the appropriate port on the inside of the adapter and tighten the ring nut and cable gland to ensure a stable connection.

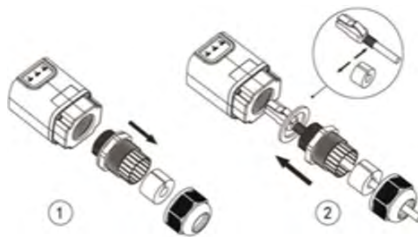
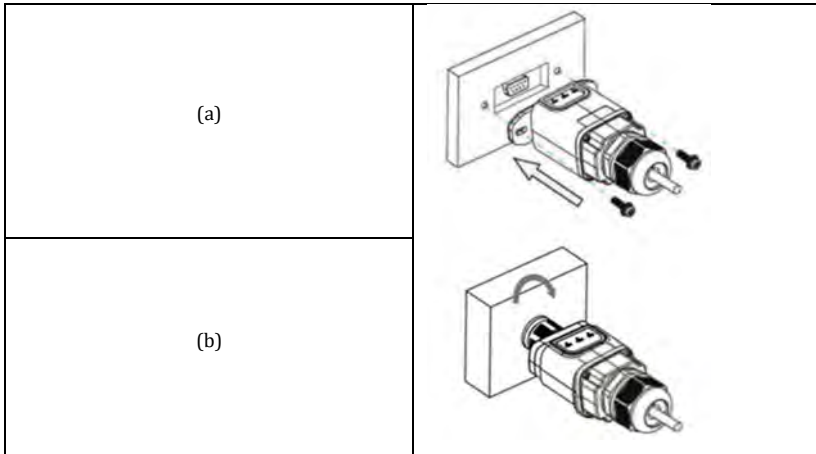

Figure 5-57 - Inserting the network cable inside the device

- 4) Connect the Ethernet adapter to the appropriate port, making sure to follow the direction of the connection and ensure correct contact between the two parts.



- 5) Connect the other end of the network cable to the ETH output (or equivalent) of the modem or a suitable data transmission device.

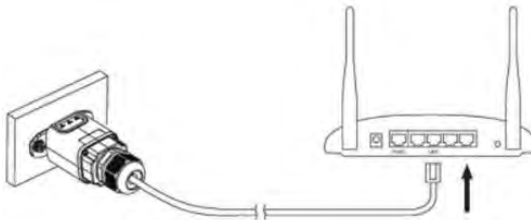

Figure 5-58 - Connecting the network cable to the modem

- 6) Switch on the inverter by following the procedure described in the manual.
- 7) Unlike Wi-Fi cards, the Ethernet adapter does not need to be configured and starts transmitting data shortly after the inverter is switched on.

Verification

Wait two minutes after installing the adapter, and check the status of the LEDs on the device.

Status of LEDs present on the adapter

Initial status:

- ✓ NET (left LED): off
- ✓ COM (central LED): steady on



- ✓ SER (right LED): flashing on



Figure 5-59 - Initial status of LEDs

Final status:

- ✓ NET (left LED): steady on
- ✓ COM (central LED): steady on
- ✓ SER (right LED): flashing on



Figure 5-59 - Final status of LEDs



Troubleshooting

Status of LEDs present on the adapter

- 1) Irregular communication with inverter
 - ✓ NET (left LED): steady on
 - ✓ COM (central LED): off
 - ✓ SER (right LED): flashing on



Figure 5-59 - Irregular communication status between the inverter and adapter

- ✓ Check the Modbus address set on the inverter:
Enter the main menu with the ESC key (first key on the left), go to System Info and press ENTER to enter the submenu. Scroll down to the Modbus address parameter and make sure it is set to 01 (and in any case, other than 00).
If the value is not 01, go to “Settings” (basic settings for hybrid inverters) and enter the Modbus Address menu where the 01 value can be set.
 - ✓ Check that the Ethernet adapter is correctly and securely connected to the inverter, making sure to tighten the two cross-head screws provided. Check that the network cable is correctly inserted into the device and modem, and that the RJ45 connector is correctly crimped.
- 2) Irregular communication with remote server
 - ✓ NET (left LED): off
 - ✓ COM (central LED): on
 - ✓ SER (right LED): flashing on





Figure 5-60 - Irregular communication status between the adapter and remote server

- ✓ Check that the router has access to the network and that the connection is stable; check that a PC can access the Internet
- ✓ Check that port 80 of the router is open and enabled to send data.

It is advisable to check the brand and model of the home router you are trying to connect to the Ethernet adapter; some router brands may have closed communication ports. In this case, contact the customer service of the router's manufacturer and ask them to open port 80 (direct from the network to external users).



5.13.6 Setting up the 4G stick

The ZCS 4G adapters are sold with a virtual SIM integrated into the device with data traffic fee included for 10 years, which is adequate for the proper transmission of data to monitor the inverter.

In order to monitor the inverter, the RS485 communication address must be set to 01 directly from the display.

Installation

Installation must be carried out for all inverters compatible with the adapter. However, the procedure is quicker and easier as there is no need to open the front cover of the inverter.

Installation tools:

- Cross screwdriver
- 4G adapter

- 1) Switch off the inverter following the procedure described in this manual.
- 2) Remove the cover for accessing the Wi-Fi/ GPRS connector on the bottom of the inverter by unscrewing the two cross-head screws (a), or by unscrewing the cover (b), depending on the inverter model, as shown in the figure.





- 3) Insert the 4G adapter into the appropriate port, making sure to follow the direction of the connection and ensure correct contact between the two parts. Secure the 4G adapter by tightening the two screws inside the package.

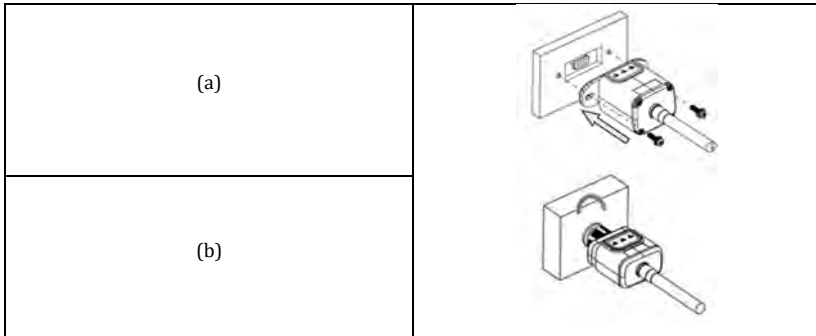

- 4) Switch on the inverter by following the procedure described in the manual.
- 5) Unlike Wi-Fi cards, the 4G adapter does not need to be configured and starts transmitting data shortly after the inverter is switched on.

Verification

After installing the adapter, within the next 3 minutes check the status of the LEDs on the device to ensure that the device is configured correctly.

Status of LEDs present on the adapter

- 1) Initial status:
 - ✓ NET (left LED): off
 - ✓ COM (central LED): flashing on
 - ✓ SER (right LED): flashing on



Figure 5-61 - Initial status of LEDs



- 2) Registration:
 - ✓ NET (left LED): flashes rapidly for about 50 seconds; the registration process takes about 30 seconds
 - ✓ COM (central LED): flashes rapidly 3 times after 50 seconds
- 3) Final status (approx. 150 seconds after the inverter has started):
 - ✓ NET (left LED): flashing on (off and on at equal intervals)
 - ✓ COM (central LED): steady on
 - ✓ SER (right LED): steady on



Figure 5-62 - Final status of LEDs

Status of LEDs present on the adapter

- 1) Irregular communication with inverter
 - ✓ NET (left LED): on
 - ✓ COM (central LED): off
 - ✓ SER (right LED): on





Figure 5-62 - Irregular communication status between inverter and adapter

- ✓ Check the Modbus address set on the inverter:
 - ✓ Enter the main menu with the ESC key (first key on the left), go to System Info and press ENTER to enter the submenu. Scroll down to the Modbus address parameter and make sure it is set to 01 (and in any case, other than 00).

If the value is not 01, go to “Settings” (basic settings for hybrid inverters) and enter the Modbus Address menu where the 01 value can be set.

- ✓ Check that the 4G adapter is correctly and securely connected to the inverter, making sure to tighten the two cross-head screws provided.
- 2) Irregular communication with remote server:
 - NET (left LED): flashing on
 - COM (central LED): on
 - SER (right LED): flashing on



Figure 5-63 - Irregular communication status between adapter and remote server



- ✓ Check that the 4G signal is present in the installation location (the adapter uses the Vodafone network for 4G transmission; if this network is not present or the signal is weak, the SIM will use a different network or will limit the data transmission speed). Ensure that the installation location is suitable for 4G signal transmission and that there are no obstacles that could affect data transmission.

- ✓ Check the status of the 4G adapter and that there are no external signs of wear or damage.





6 Installation of the ZCB8000-64/80/96kWh System

6.1 Cabinet System Instructions

All operations on this equipment must be carried out by qualified and trained electrical technicians or certified commissioning personnel. Operators must be fully familiar with the system structure, operating principles, and the applicable regulations of the country/region where the project is installed.

Carefully read the user manual before installing the equipment to fully understand the product information and safety precautions. Any damage caused by storage, transportation, installation, or operation that does not comply with this document and the user manual is not covered by the product warranty.

During installation, insulated tools must be used. For personal safety, appropriate Personal Protective Equipment (PPE) must be worn.

During installation or operation, if personnel leave the equipment unattended, even for a short period, the cabinet door must be closed.

If the equipment is scratched or the paint coating is damaged due to impacts during transportation or installation, repair the affected area using Y3-1172W outdoor paint (white) or RAL9011 paint (black).

For the mounting locations of installation components, screws, and other supplied accessories, refer to the **Packing List**.

6.2 Cabinet System Installation Requirements

Cabinet Installation Area

The minimum required installation clearances for the cabinet are shown in the figures below.

Installation clearance for the Energy Storage Cabinet and Inverter:

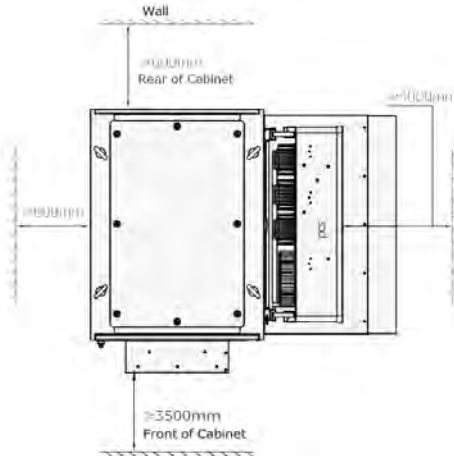

Installation clearance for Energy Storage Cabinets and Inverters installed face-to-face:

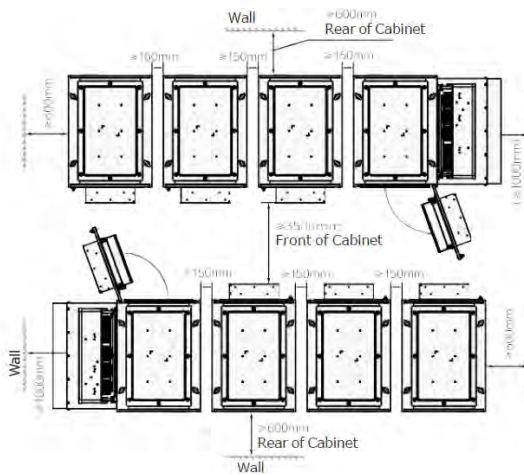



Installation clearance for Energy Storage Cabinets and Inverters installed back-to-back:

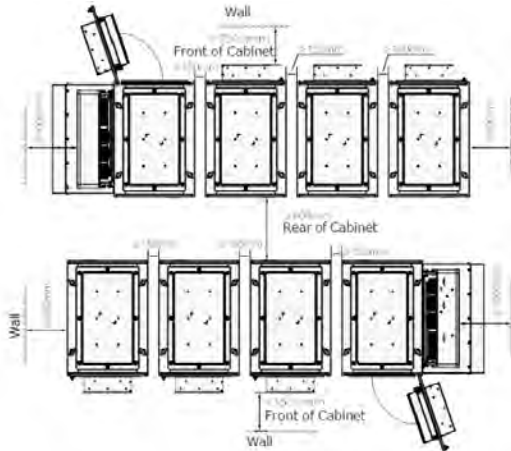

6.3 Cabinet System Product Overview

The foundation requirements shall comply with the specifications provided in the site design drawings. For detailed drawings, please contact the pre-sales department of Zucchetti Centro Sistemi S.p.A.

Cabinet installation layout:

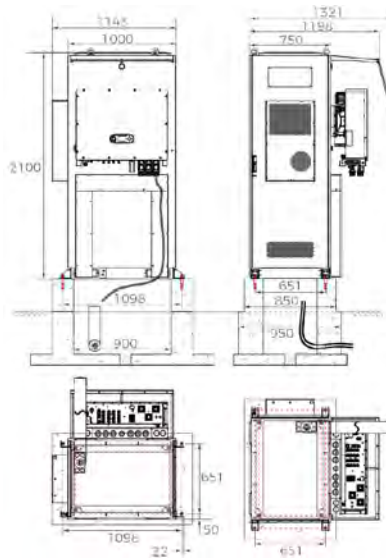



Parallel connection diagram of cabinets:

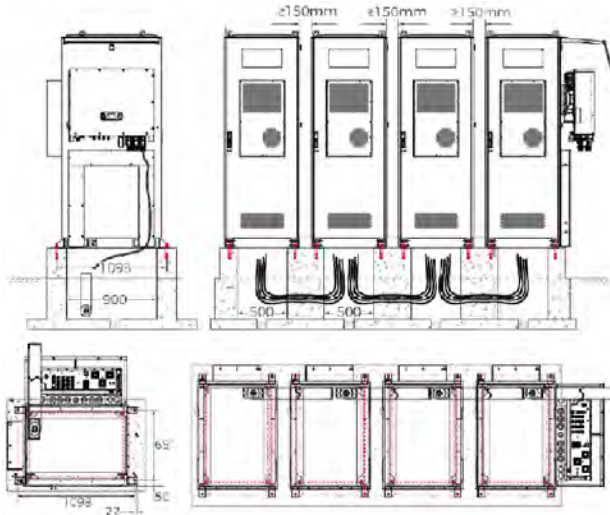

6.4 Delivery Inspection – Cabinet System

Standard configuration

Energy storage cabinet + cabinet accessory kit + other customized requirements (as shown in the figure below).

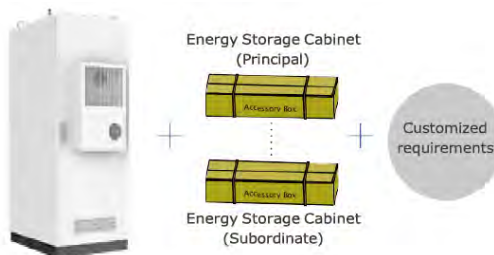

Please verify the delivered items and their quantities by comparing them with the Shipping List and the Packing List. In case of missing items, please contact the distributor or after-sales service.







 1 PCS	 1 PCS	 1 PCS	 1 PCS	
 1 PCS	Pacchetto cavi A		 M20 4 PCS	 1 PCS
 Connettore impermeabile	 M10*30 4 PCS	 M5*12 16 PCS	 M4*12 25 PCS	 M6*30 12 PCS
 50 (KKT*50) 6 PCS	 40 (KKT*40) 1 PCS	 1 PCS	 20 PCS	/







 M20 4 PCS	 1 PCS	 20 PCS	 1 PCS	 Pacchetto cavi B

 M20 4 PCS	 1 PCS	 20 PCS	 1 PCS	 Pacchetto cavi C















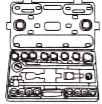







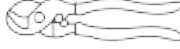
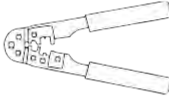

 4 PCS	 M5*25 18 PCS	 20 PCS	 M16*150 5 PCS	/
--	---	---	--	---

 Energy Storage Cabinet (F) ZYT-POWER-MINI-KIT-PAR				
 M20 4 PCS	 1 PCS	 20 PCS	 1 PCS	 Pacchetto cavi F

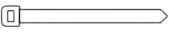
 Steel base ZYT-BASE-POWER-MINI			
 1 PCS	 2 PCS	 4 PCS	 4 PCS
 1 PCS	 1 PCS	 M16*150 5 PCS	 70 (KKT*70) 12 PCS
 M16*40 6 PCS	 M16*13 6 PCS	 M8*25 61 PCS	/

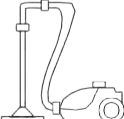
6.5 Cabinet System Installation

Tools

 Trapano a percussione (Punte: Φ 14 mm, Φ 16 mm)	 Chiave a bussola	 Chiave	 Pinze diagonali	 Spellafili
 Cacciavite a testa piatta (testa: 0,6 mm*3,5 mm)	 Martello di gomma	 Trincetto	 Pennarell	 Metro a nastro in acciaio
 Livella digitale o a bolla	 Crimpatrice idraulica	 Tagliacavi	 Crimpatrice RJ45	 Multimetro (intervallo di tensione CC \geq 1500 V CC)
 Guaina	 Pistola a caldo	 Fascette	 Scala isolata	 Aspirapolvere
 Gru	 Fune di sollevamento	 Carrello		





6.6 Lifting and Transport Using a Forklift – Cabinet System

Lifting

Use 4 M20×30 lifting rings, supplied in the accessory kit.

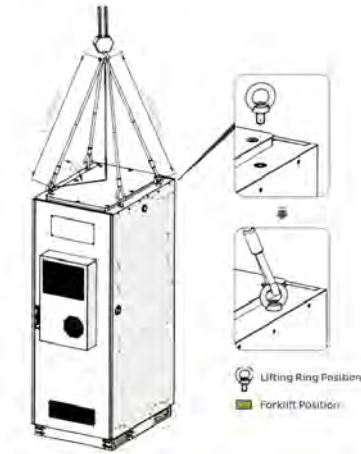

Before lifting, ensure that the concrete foundation meets the installation requirements, that the foundation surface has the correct positioning markings, and that the energy storage system is correctly oriented in accordance with the markings.

The crane lifting capacity must be greater than 6 tons, with a working radius of no less than 5 m.

Forklift Transport



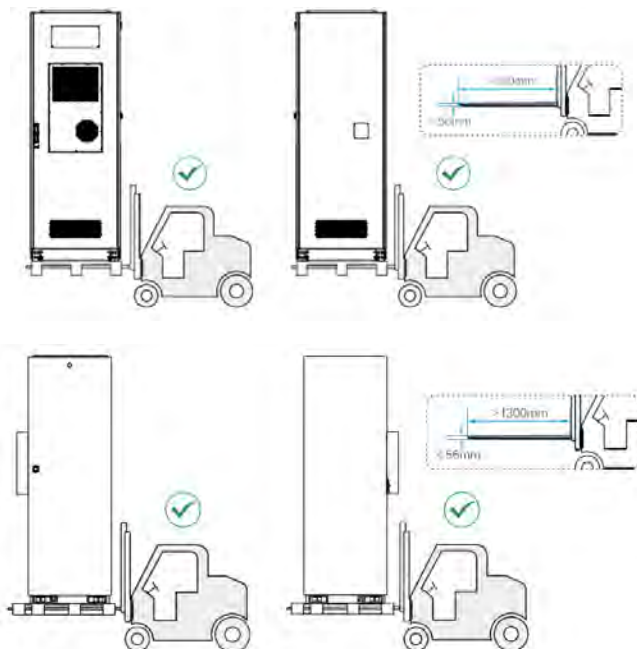

The forklift load capacity must be greater than 4 tons. If on-site working conditions do not meet the requirements, contact a qualified professional for assessment.





6.7 Installation of the Energy Storage System – Cabinet

Standard installation (without steel base)

1. Remove 4 pieces of M16×150 expansion bolts from the supplied accessory kit.
2. Insert the expansion bolts into the concrete foundation according to the required installation dimensions.
3. Secure the cabinet to the concrete floor using the expansion bolts.
4. Complete the installation and perform an inspection.

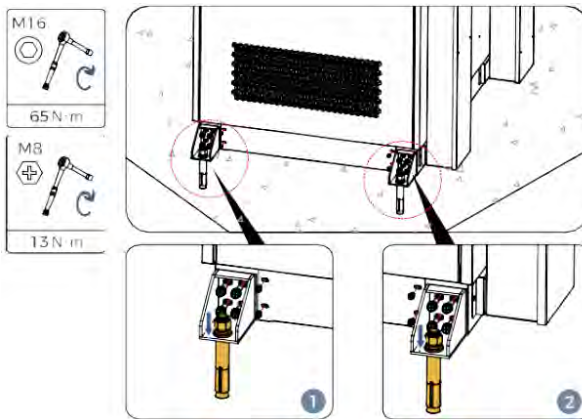



Installation of the Steel Base (Optional)

1. Lift or move the steel base into the designated position, ensuring that the black side of the steel base faces the opposite direction of the intended opening direction of the equipment doors.
2. Secure the steel base to the concrete floor using expansion bolts.
3. Firmly fix the energy storage cabinet to the steel base using bolts.
4. Install the cover plates and the metal components for parallel connection.

Complete the installation and perform an inspection.

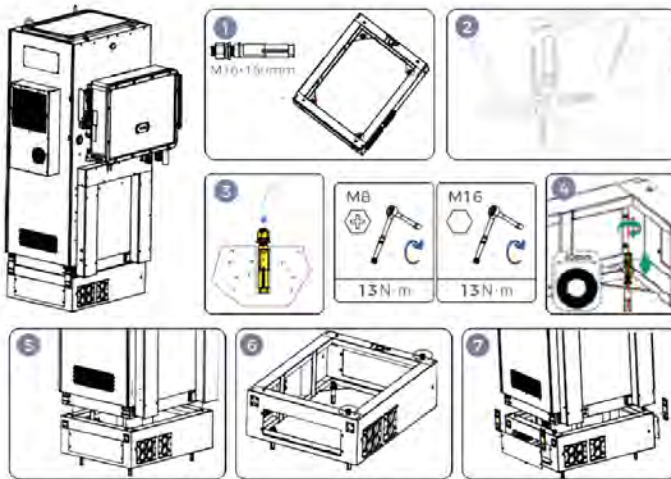



6.8 Installation of the Sunshade Kit – Cabinet System

Use 11 M6×30 screws and 2 M5×12 screws from the accessory kit. The sunshade cover is also included in the kit.

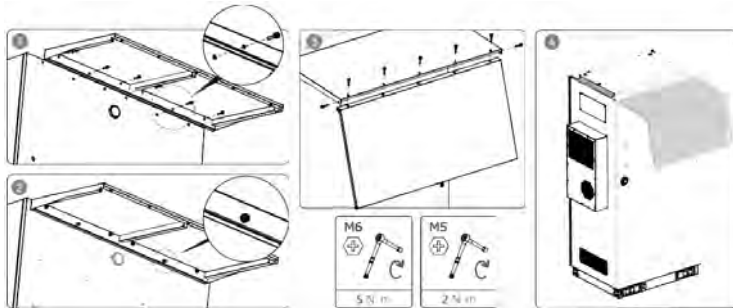

6.9 Installation of the PV Inverter Mounting Bracket (Cabinet System)

Use 4 M10×30 screws from the accessory kit. The PV inverter mounting bracket is included in the inverter package.

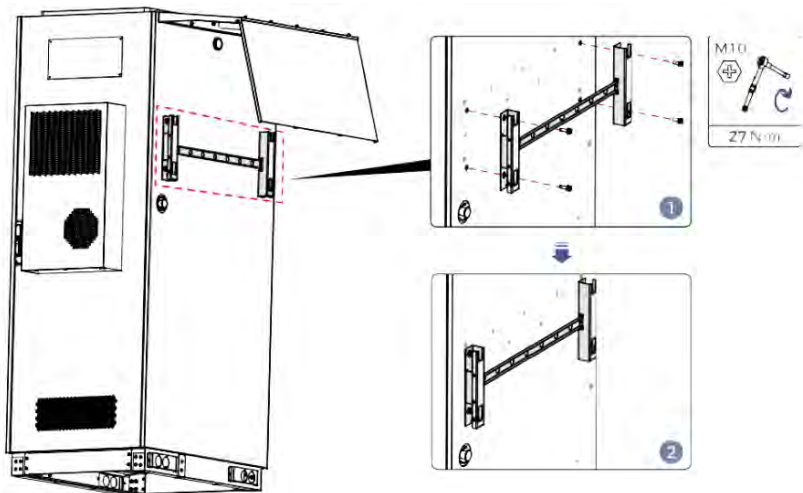



6.10 Installation of Cable Glands – Energy Storage System (Cabinet System)

Use 23 M4×12 screws, 13 M5×12 screws, 10 50 cable glands (KKT50), and 1 40 cable gland (KKT40) from the accessory kit. Cable trays are also included in the kit.

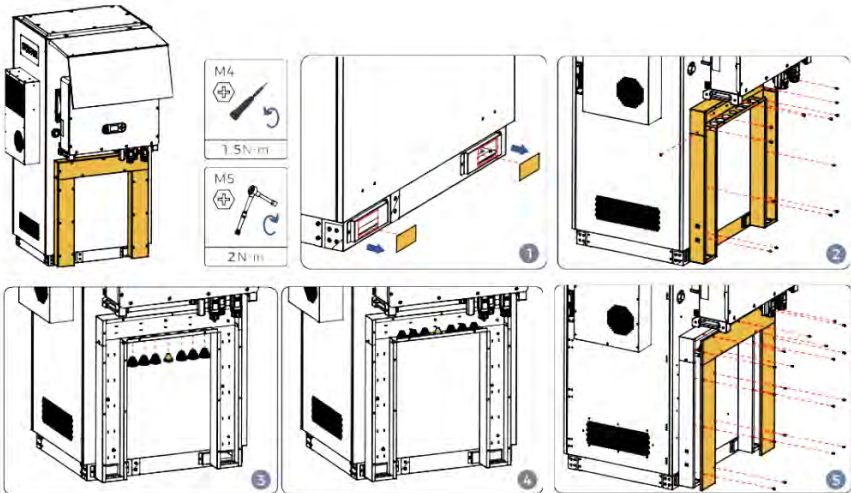



6.11 Installation of the Grounding Conductor – Energy Storage System (Cabinet System)

Use 4 M10×30 screws from the accessory kit. Ensure that the grounding resistance is $\leq 4 \Omega$.

Grounding cable

Use a grounding cable with a cross-section of 25 mm² to 50 mm² to ensure a reliable connection between the energy storage cabinet and the site grounding system.

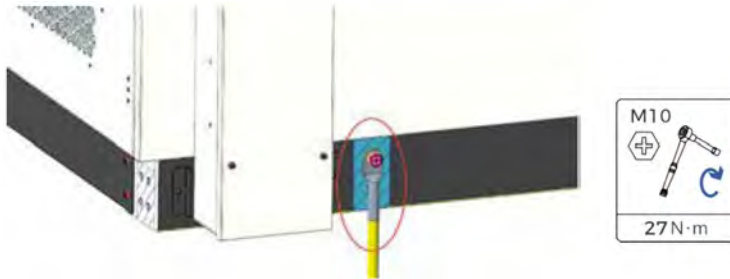

6.12 Installation of the Air Conditioning Drain Pipe (Cabinet System)

Install the air conditioning drain pipe according to actual site conditions.

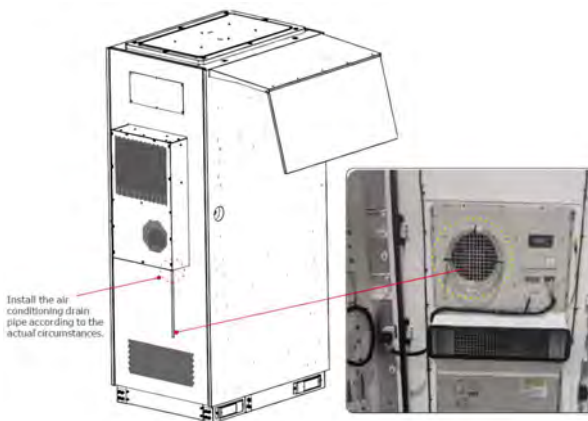

6.13 Installation of Connection Cables (Cabinet System)

Prepare the required cables and proceed using the supplied accessory kit.

1. Connect the power cables between the BCU and the inverter.

Connect the BCU power cables, ensuring correct cable polarity. Route the cables along the cabinet and cable trays, and fully insert the cable terminals until a “click” is heard.

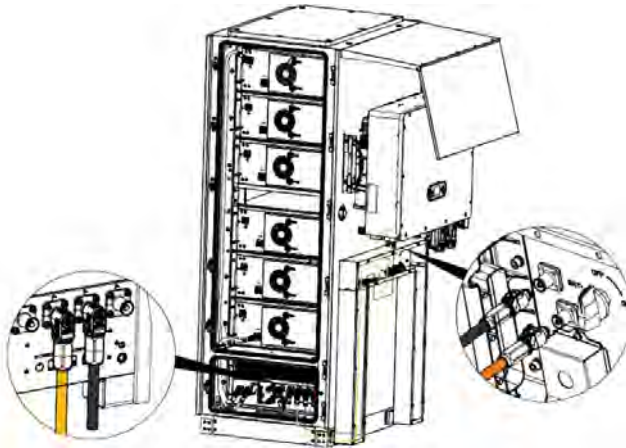

2. Connect the communication cables between the BCU and the inverter.
 - a. Waterproof cover for the BCU communication terminal.

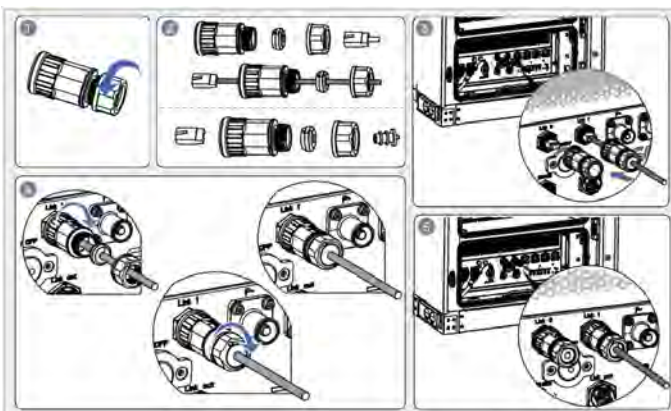



- b. Route the communication cables along the cabinet and cable trays, then connect them to the inverter COM connector.

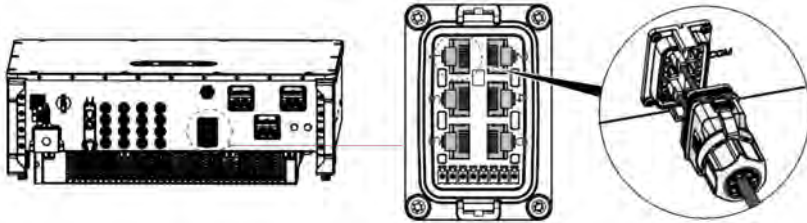

3. Connect the power cables between the cabinet and the inverter.

Route the dedicated cabinet power cables along the cabinet and cable trays, then connect them to the inverter load port.

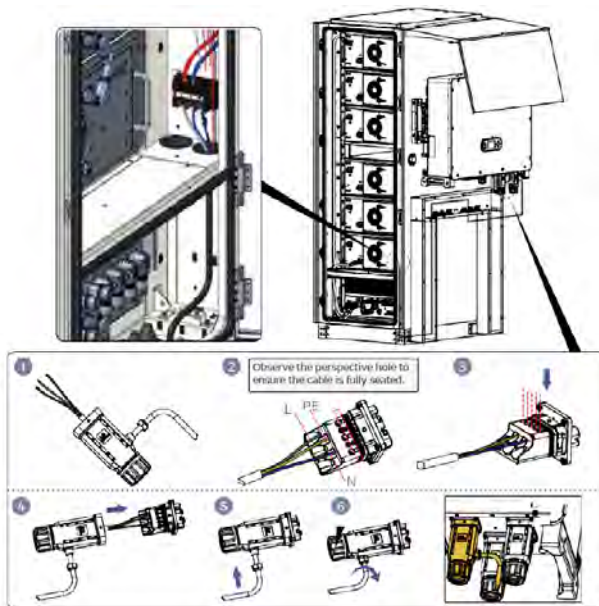

4. Emergency stop system wiring.

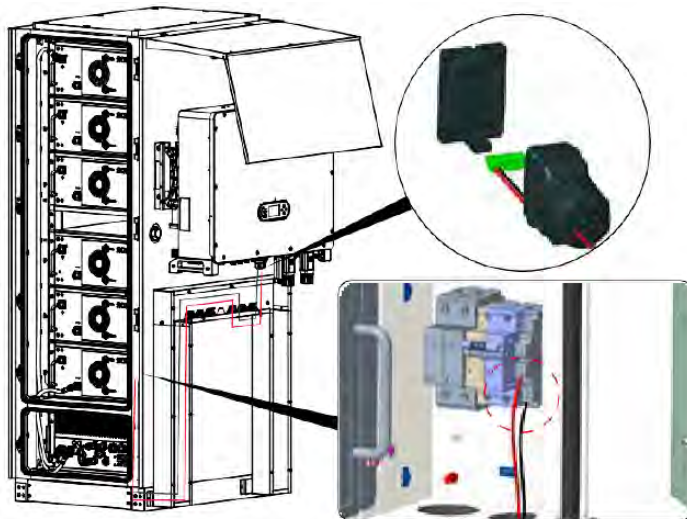

5. Parallel connection with the inverter.
Battery and communication cable connection.

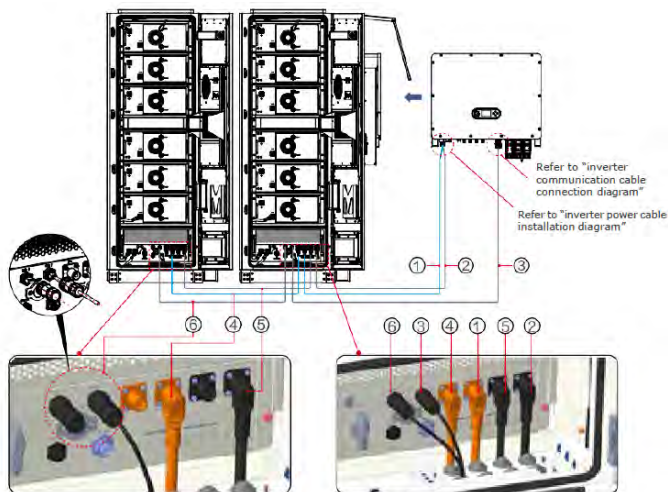



Parallel power cable connection.

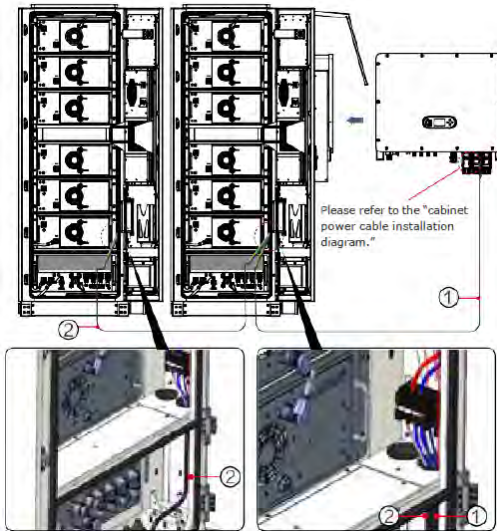

Parallel EPO (Emergency Power Off) button connection.

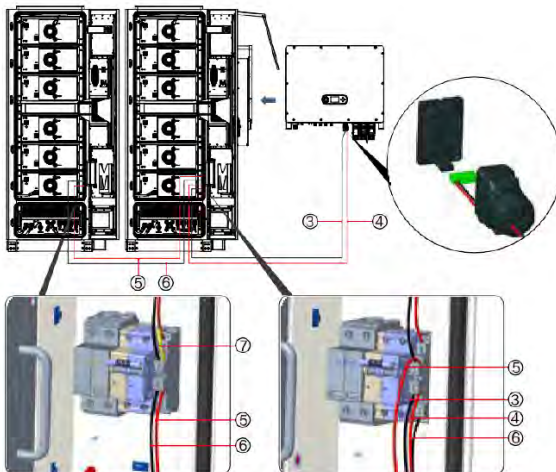



6.14 Power-On

Power-on sequence

1. Turn on the inverter battery door switch.



2. Turn on the cabinet circuit breaker.



3. Turn on the DC battery switch.



4. Turn on the DC battery switch again. Press the BCU ON/OFF start button.





7 Commissioning the inverter

7.1 Safety test before commissioning

NOTICE

Check the voltage range

- ▶ Ensure that the DC and AC voltages are within the permissible range of the inverter.

7.2 Double Check

Please ensure that the inverter and all the wiring are installed correctly, securely, and reliably, and that all environment requirements are met.

1. Inverter is firmly fastened to the mounting bracket on the wall.
2. PV+/PV- wires are firmly connected, polarity and voltage are correct.
3. BAT+/BAT- wires are firmly connected, polarity and voltage are correct.
4. DC isolator is correctly connected between battery & inverter, DC isolator: OFF.
5. GRID / BUCKUP/GENERATOR cables are firmly / correctly connected.
6. AC circuit breaker is correctly connected between inverter GRID & GRID & GEN port, circuit breaker: OFF.
7. AC circuit breaker is correctly connected between inverter BUCKUP port & critical load, circuit breaker: OFF.
8. For battery, please ensure that the communication cable has been correctly connected.

7.3 Starting the inverter

Please follow below steps to switch the inverter ON.

1. Make sure there's no power generation in inverter from grid.
2. Turn ON PV switch.
3. Turn ON DC isolator between battery & inverter. Switch ON the battery.
4. Turn ON AC circuit breaker between the inverter GRID port & GRID.
5. Turn ON AC circuit breaker between the inverter BUCKUP port & critical load.
6. Inverter should start to operate now.

7.4 Initial setup

You need to set the following parameters before inverter starts to operate.

Parameter	Note
1. Language setting	The default is English
2. System time setting	If you are connected to the server or using the App, the time is set to the local time automatically
3. Safety parameter import	Refer to the country code table below and select country and code.
4. Application scenario setting	According to the user application scenario configuration, set the parameters of PV port, BAT port, GRID port, BACKUP port and Gen port. If a battery is connected to BAT1 input, select "Bat Input1", otherwise "Not Use"
5. Work mode setting	Set different working modes, and configure parameters for different working modes (Self-use, Feed-in Priority, Peak Shaving, Time-of-use, Passive), and set battery energy storage parameters (Charge Cut-off SOC, On-grid Discharge Cut-off SOC, Off-grid Discharge Cut-off SOC, Off-grid Discharge Recovery SOC).

The default operating mode is the Self-use Mode.





7.4.1 Configuring the battery setup

AZZURRO 3PH HYD 30000...60000 ZSR models have one battery input (max. current 100 A).

7.4.2 Configuring Parallel Inverter System

To increase the system's BACKUP and grid power, the AZZURRO 3PH HYD 30000...60000 ZSR can be parallely connected at the Grid port and the BACKUP port.

For the communication setup, please follow the following steps:

1. Set the Master unit
2. Set the Slave units

► Each inverter must have a unique parallel address

7.4.3 Setting the country code

1. Different distribution network operators in various countries have differing requirements for the grid connection of grid-coupled PV inverters.
2. Ensure that you have selected the correct country code according to regional authority requirements, and consult a qualified electrician or employees of electrical safety authorities.
3. Zucchetti Centro Sistemi Spa is not responsible for the consequences of selecting the incorrect country code.
4. The selected country code influences the device grid monitoring. The inverter continuously checks the set limits and, if required, disconnects the device from the grid.

► for an updated list of country codes according to the Firmware version, just you can check the document under this link:

<https://www.zcsazzurro.com/it/>

8 Operation of the device

This chapter describes the LCD and LED displays of the AZZURRO 3PH HYD 30000...60000 ZSR inverter.

8.1 Control panel and display field

8.1.1 Buttons and display lights

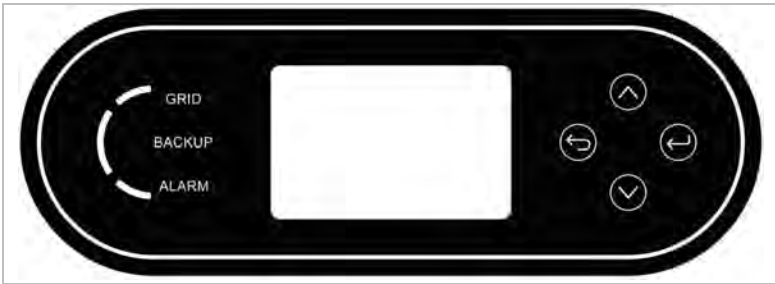





Figure 7-1 Main interface

Buttons

Button	Name	Description
	Back	Previous screen, enter menu
	Up	Select previous menu item, increase setting value
	Down	Select next menu item, decrease setting value
	Enter	Enter Menu item, select next digit, confirm setting



LEDs

State	Colour	State
On-grid	Green	Normal
	Green (flashing)	Standby
Off-grid	Green	Normal
	Green (flashing)	Standby
Alarm	Red	Error



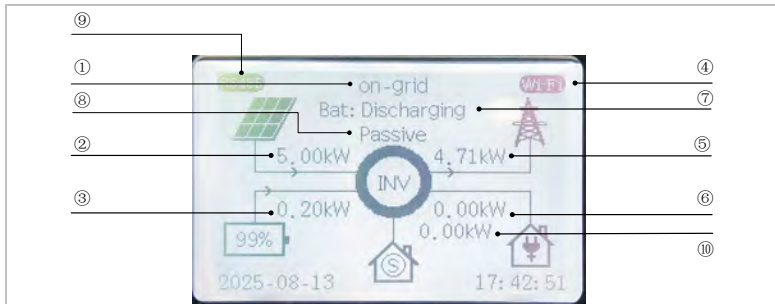



8.2 Standard display

The screen shows all relevant information of the inverter:



① Current state of the inverter	Used to display the current working status of the inverter, including grid-connected, off-grid and standby.	
② PV Power	For displaying photovoltaic power.	
③ Battery Power	For displaying BAT charge or discharge power. No battery marking here if no battery is connected	
④ Accessory		This is used to display the accessories currently connected to the inverter,
		



		including the capture stick, USB, and smart meter.
⑤ Grid Power		This port can be used to display grid power or generator power.
		
⑥ Home Consumption	Energy consumed by household loads	
⑦ PV channel enable state	Used to display the current number of PV input channels open	
⑧ Work Mode	Displays the current operating mode of the inverter, the specific operating mode is described in 7.3	
⑨ Master-slave state		Used to connect multiple inverters in parallel, indicating whether the current inverter is in the master or slave position.
⑩ Generator Power		This port can be used to display generator power and emergency load power.
		This port can also be configured to not be used, and there will be no display at this location

8.3 Energy storage modes

The AZZURRO 3PH HYD 30000...60000 ZSR comes with several integrated energy management modes.

8.3.1 Self-use Mode (Priority: Loads > Battery > Grid)

The self-use mode is suitable for areas with low feed-in subsidies and high electricity prices. The power of PV will supply the loads first, and the surplus power will charge the battery, then the remaining power will feed into the grid.



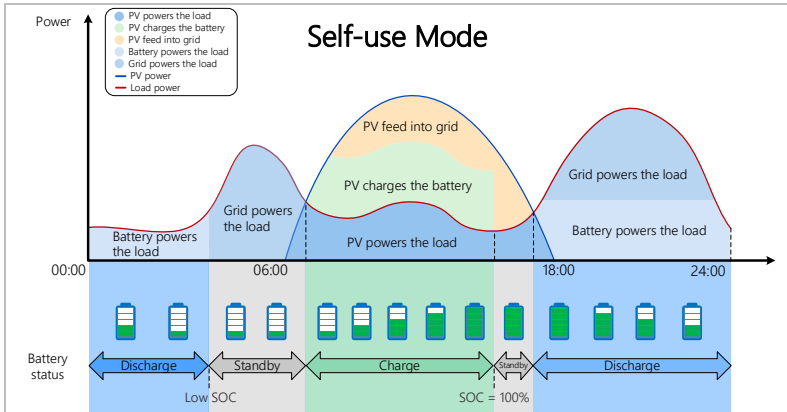

PV is sufficient: The power generated from PV prioritizes supplying the load. Any excess power is then directed towards charging the battery, and if there is still surplus electricity, it can be sold to the grid.

PV is insufficient: The battery discharges power to the load, and once its capacity reaches Min SOC, it automatically ceases discharging.

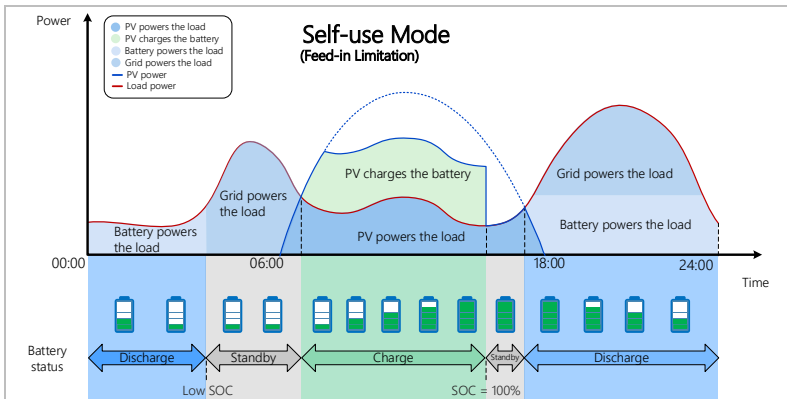

In the event that the local utility restricts the sale of electricity to the grid, the export control value can be set on the inverter.

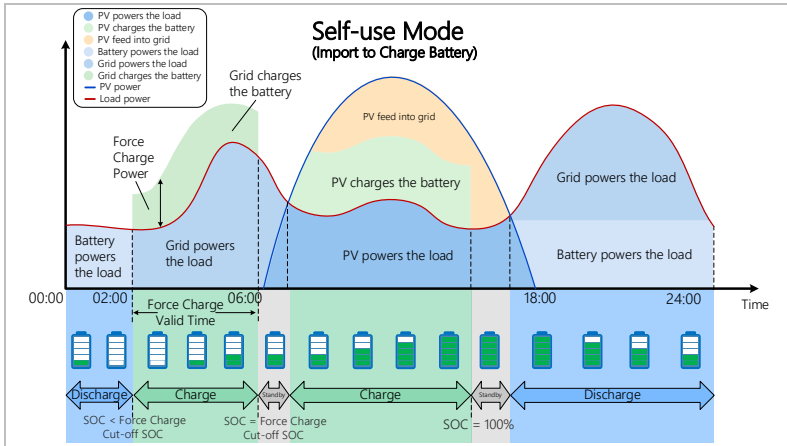

In the self-use mode, it is also possible to set whether the inverter charges the battery from the grid.

In the Self-use mode, the inverter will automatically charge and discharge the battery according to the following rules:

Setting Method 1: Battery First: Disabled; Charging from Grid: Disabled The priority of power supply: PV, Battery, Grid. The priority of power consumption: Loads, Battery, Grid.

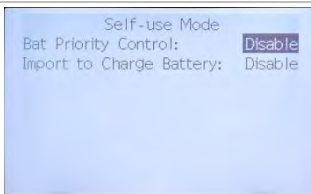

Set Self-use Mode 1



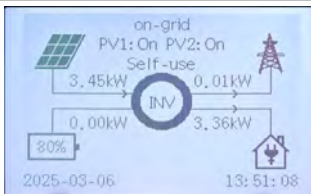

If PV generation equals the load consumption ($\Delta P < 100$ W), the inverter won't charge or discharge the battery

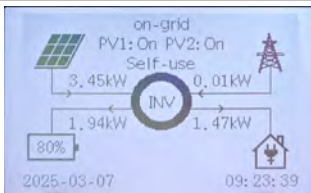

If PV generation is larger than the load consumption, the surplus power is stored in the battery

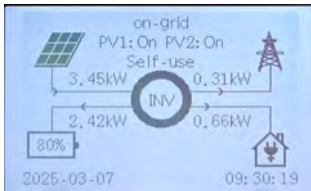

If the battery is full or at maximum charging power, the excess power will be exported to the grid

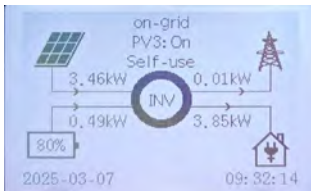

If the PV generation is less than the load consumption, it will discharge the battery to supply power to the load.

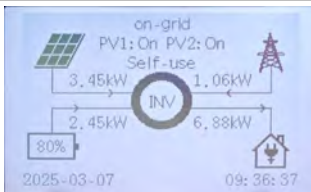

If PV generation plus Battery discharge power is less than the load, the inverter will import power from the grid.

- ▶ If it is not allowed to export power to the grid, an energy meter and/or CT needs to be installed, and the "feed-in limitation" function needs to be enabled.



Setting Method 2: Battery First : Enabled, Battery First Cut-off SOC : 90%; Charging From Grid: Disabled. The priority of power supply: PV, Battery, Grid. The priority of power consumption: Loads, Battery, Grid.

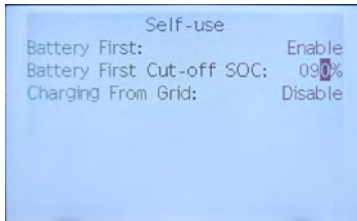

Set Self-use Mode 2

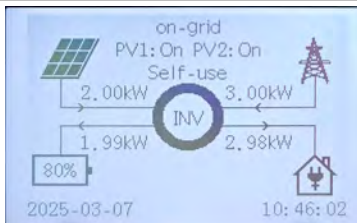

If the PV power is less than or equal to the battery charging power and the battery SOC is less than 90%, the inverter prioritizes charging the battery and the grid supplies power to the household loads.

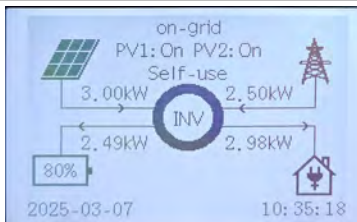

If the PV generation power is greater than the battery charging power and the battery SOC is less than 90%, the inverter prioritizes charging the batteries, and the remaining energy generated by the PV power is used with the grid to power the household loads.

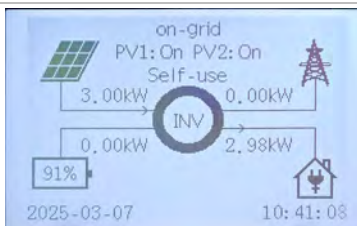

If the batteries continue to charge and the battery SOC reaches 90%, the inverter stops charging the batteries and all of the energy generated by the PV power is supplied to the household loads.





Setting Method 3: Bat Priority Control: Disabled; Import to Charge Battery: Enabled.

When the inlet battery charging enable is turned on, the user can set the amount of specific charging time range, the maximum battery charging power, and the maximum cut-off SOC for forced charging through the LCD.

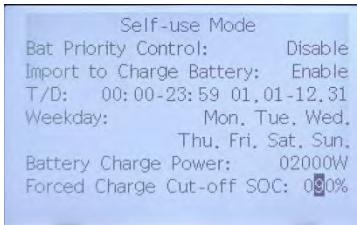

Setting Method 3

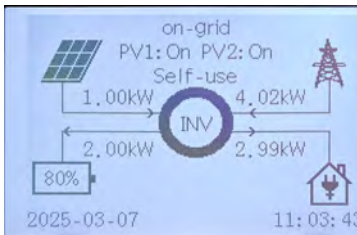

If the PV power is less than the battery charging power and the battery SOC is less than 90%, the inverter gives priority to charging the battery while taking power from the grid to charge the battery, and the load power is provided by the grid.

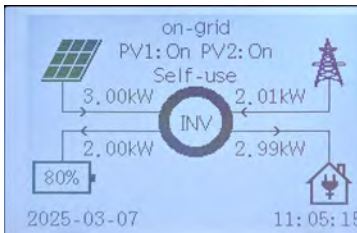

If the PV generation power is greater than the battery charging power and the battery SOC is less than 90%, the inverter prioritizes charging the batteries, and the remaining energy generated by the PV power is used with the grid to power the household loads.

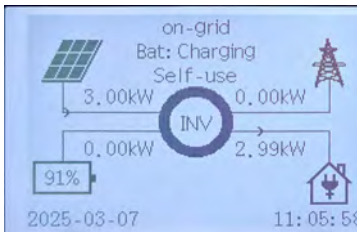

If the batteries continue to charge and the battery SOC reaches 90%, the inverter stops charging the batteries and all of the energy generated by the PV power is supplied to the household loads.

Setting Method 4: Battery First: Enabled; Charging From Grid: Enabled. In this mode, the Battery First and Battery First Cut-off SOC functions are in effect at the same time, see Setting Method2, 3 for details.

Self-use	
Battery First:	Enable
Battery First Cut-off SOC:	000%
Charging From Grid:	Enable
T/D:	00:00-23:59 01.01-12.31
Weekday:	Mon, Tue, Wed, Thu, Fri, Sat, Sun,
Charging Power Limit:	02000W
Charge Cut-off SOC:	000%

Setting Method 4

8.3.2 Feed-in Priority Mode (Priority: Loads > Grid > Battery)

The feed-in priority mode is suitable for areas with high feed-in subsidies, but has feed in power limitation. The power generated from PV is directed towards supplying the loads. Any excess power beyond the load requirements will be fed into the grid. If the amount of electricity sold to the grid reaches the set limit threshold, the remaining power will be used to charge the battery.

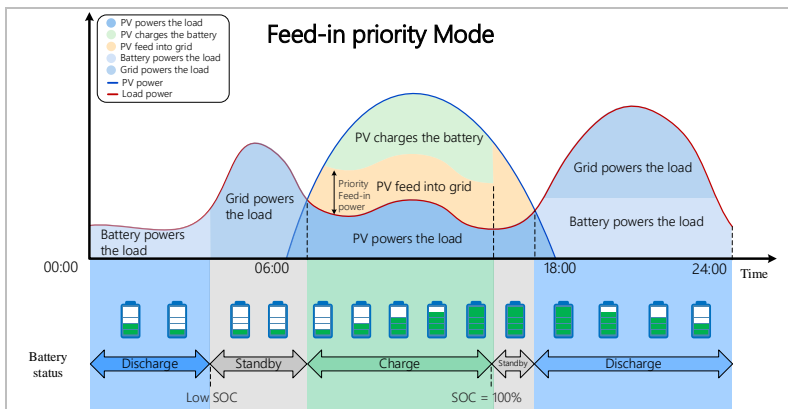

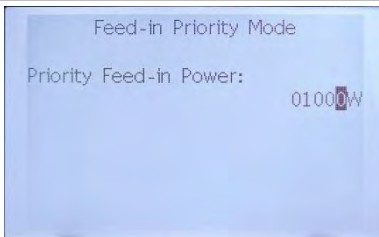

Feed-in Priority Mode

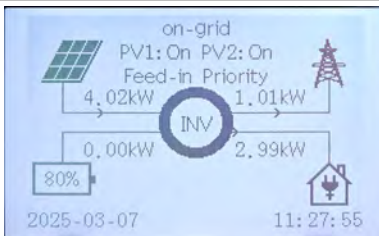

In this mode, the user can set the maximum feeder power, when the PV power minus the load consumption power is less than or equal to the feeder power (for example, 1KW), the excess energy generated by the PV power generation is delivered to the grid.

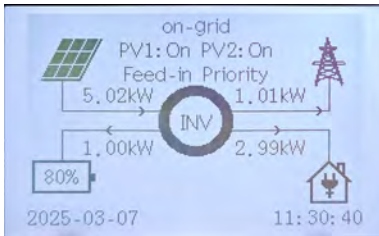

In this mode, the user can set the maximum feeder power, when the PV power minus the load consumption power is greater than the feeder power (for example, 1KW), the extra energy will be used to charge the battery.

8.3.3 Peak Shaving Mode

Peak shaving mode is set for leveling out peaks in electricity use. The system is intelligently controlled to ensure charging takes place during off-peak hours and discharging occurs during peak hours.

The power of PV will supply the loads first. when PV is insufficient, it prioritizes purchasing electricity from the grid. When the grid purchases electricity beyond the set threshold, the battery discharges. If the battery discharge is still insufficient, it continues to purchase electricity from the grid.

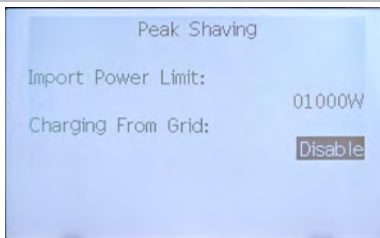
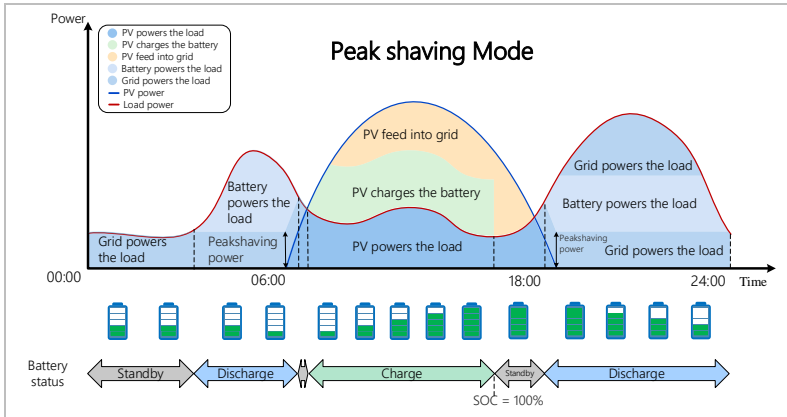

Charging From Grid : Disable

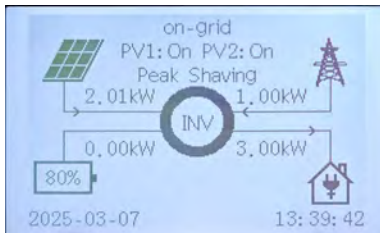

When the PV power is not enough to supply the load consumption, the grid starts to supply power to the load, and the maximum power taken from the grid does not exceed the Priority Import Power.

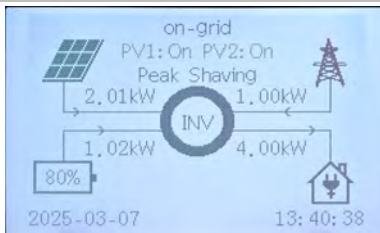

When the PV power and Priority Import Power are also insufficient to supply the load consumption, the battery starts discharging to supply the load consumption at the same time.

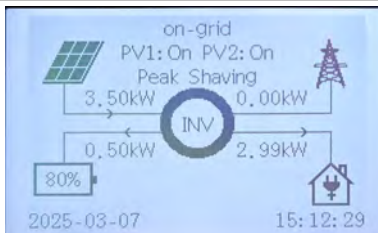

When the photovoltaic power generation is greater than the load consumption, the excess energy to charge the battery, when the battery SOC is greater than the set value, the excess energy flows to the power grid.

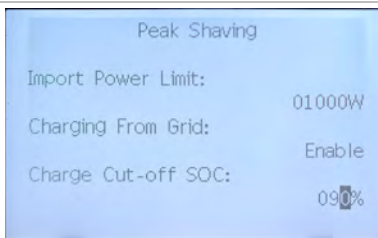

Charging From Grid : Enable

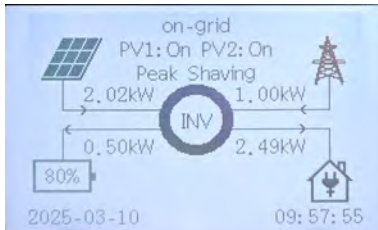

When "Charging From Grid" is enabled and there is not enough PV power to supply the load and the load consumes less than the Import Power Limit, the grid starts to supply power, which is less than then Import Power Limit setting.

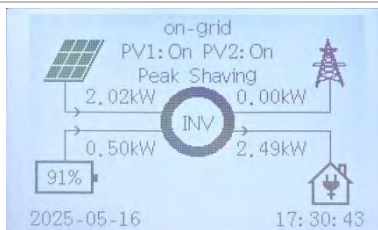

When the battery SOC is greater than the set value, the battery and the PV supply power to the load at the same time.



8.3.4 Time-of-use Mode

In the Time-of-use mode, different working modes, i.e Self-use, Charging, Discharging, Peaking shaving and Battery off can be set for different time periods in accordance with actual needs and environment conditions through LCD.

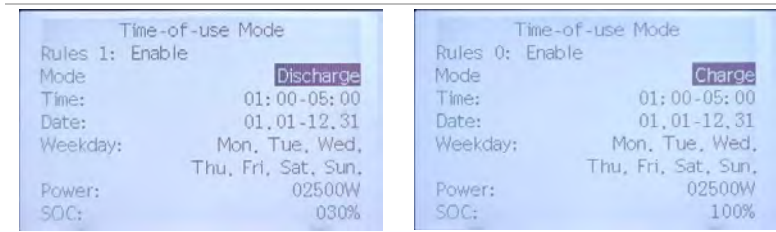
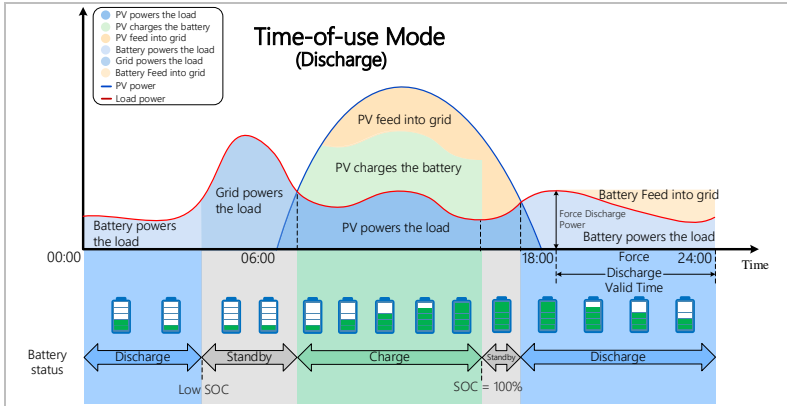

Up to 5 rules (rule 0, 1, 2, 3 and 4) can be set. If more than one rule is valid for any given time, the rule with the lower number is active. Each rule can be enabled or disabled, also charging and discharging period for a rule can be enabled separately.

In the above example, Rule 0 :the battery will be charged with 2.5 kW between 1 and 5 o'clock at night, and Rule1: discharged with 2.5 kW between 1 and 5 o'clock . In case of conflict between Rule 0 and Rule 1, Rule 0 takes precedence.



8.3.5 Passive Mode

The passive mode is used in systems with external energy management systems. The inverter's operation will be controlled by the external controller using the Modbus RTU protocol. Please contact Zucchetti Centro Sistemi Spa if you need the Modbus protocol definition for this device.

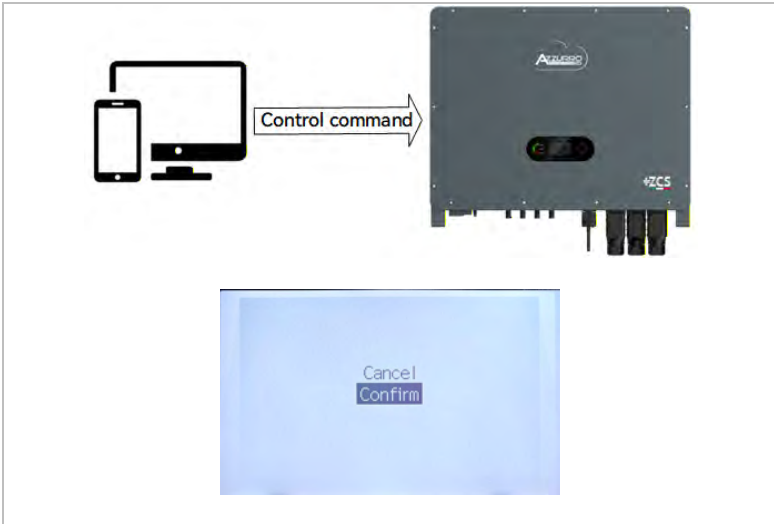

8.3.6 Energy Storage Settings

In this interface the user can set four battery charging and discharging states, Charge Limit SOC, On-grid Discharge Limit SOC, Off-grid Discharge Limit SOC, Off-grid Recovery Discharge SOC.



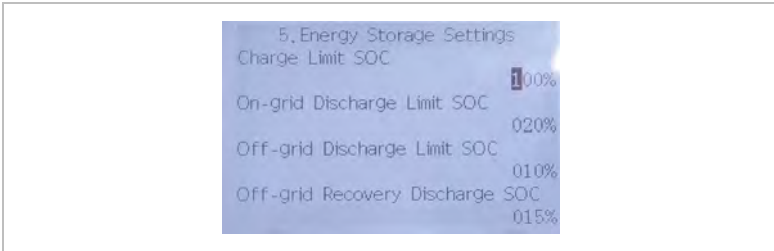

8.4 “Firmware update” menu

On first installation, all Zucchetti hybrid inverters must be updated to the latest firmware version found in the www.zcsazzurro.com website, unless the inverter is already updated to the version on the website or to a later version (see image below).



ATTENTION!!! Downgrading the firmware version of the inverter could lead to a malfunction.

3PH HYD30000-60000-ZSR inverters must be upgraded using an 8 GB USB stick.

3PH HYD30000-60000-ZSR inverters offer software upgrade via USB flash drive to maximize inverter performance and avoid inverter operation error caused by software bugs.





When you do a firmware update, please upgrade with PV input or grid status, the update will fail if only the battery is connected.

▶ If you want to do a firmware update, please upgrade with PV input or grid status, the update will fail if only the battery is connected.

1. Insert the USB stick into the computer.
2. Inside the website www.zcsazzurro.com you will find the latest version of the software to carry out the update.
3. Unzip the file and copy the original file to a USB stick. Attention: The firmware upgrade file must be in the "firmware" subfolder!
4. Press the "Back" on the main interface to enter the main menu page, and select "2.Advanced Settings - Switch On/Off -Switch Off". Make the inverter shut down safely.
5. Insert the USB flash drive into the USB interface of the inverter.
6. Go to menu item "7.Firmware Upgrade" on the LCD display.
7. Enter the password (the standard password is 0715) and then select "Firmware Upgrade".
8. Enter the password (the standard password is 0715) and then select "Inverter" or "Battery".
9. The system will then sequentially update all parts. Pay attention to the displays.
10. If an error message appears, please upgrade again. If this continues many times, contact technical support for help.
11. After the update is complete, Go to menu item "Advanced Settings - Switch On/Off - Switch On" to make the inverter start up and run.
12. You can check the current firmware version in item "Inverter(1)" of the "System information" menu.

9 Troubleshooting handling

9.1 Troubleshooting

This section contains information and procedures pertaining to the remedying of potential problems with the inverter.

To carry out troubleshooting, proceed as follows:

- ▶ Check the warnings, error messages or error codes displayed on the screen of the inverter.
- ▶ If no error information is displayed on the screen, check whether the following requirements have been fulfilled:
 - ▶ Has the inverter been set up in a clean, dry, well-ventilated area?
 - ▶ Is the PV switch set to ON?
 - ▶ Are the cables sufficiently dimensioned and short enough?
 - ▶ Are the input connections, output connections and the wiring all in good condition?
 - ▶ Are the configuration settings for the relevant installation correct?
 - ▶ Are the display field and the communication cables correctly connected and undamaged?

Follow the steps below to view recorded problems: Press "Back" to enter the main menu in the normal interface. In the interface screen select "Event List", then press "OK" to enter events.

9.1.1 Shutdown procedure

If the inverter needs to be shut down for electrical inspection, please follow the following steps:

1. Press the "Back" on the main interface to enter the main menu page, and select Advanced Settings - Switch On/Off - Switch Off. Make the inverter shut down safely.
2. Disconnect the AC circuit breaker connecting the inverter power grid port to the power grid.
3. Disconnect the AC breaker connecting the inverter load port to the emergency load.
4. Disconnect the PV side PV switch.





5. Turn off the battery and disconnect the PV switch between the battery and the inverter.
6. Wait for 5 minutes before checking the inverter.

- ▶ After using the menu setting to shut down the inverter, the inverter should be checked and reenergising, it still needs to be on the main menu page. Select advanced Settings - Switch On/Off- Switch On. start up to enable the inverter to start up and run.

9.1.2 Earth fault alarm

This inverter is compliant with IEC 62109-2 Clause 13.9 and AS/NZS 5033 for earth fault protection.

If an earth fault alarm occurs, the error is displayed on the LCD screen, the red light illuminates and the error can be found in the error history log.

When the inverter is connected to the battery system, when the battery system has ground fault/leak alarm in accordance with AS/NZS 5139, the inverter will also alarm. The alarm method is the same as above.

- ▶ In the case of devices equipped with a stick logger, the alarm information can be viewed on the monitoring portal and retrieved via the smartphone app.



9.2 Error list

9.2.1 Inverter error list

ID	Code Name	Description	Solution
001	GridOVP	The voltage of the power grid is too high	<p>If the alarm occurs occasionally, the possible cause is that the electric grid is abnormal occasionally. Inverter will automatically return to normal operating status when the electric grid's back to normal.</p> <p>If the alarm occurs frequently, check whether the grid voltage/frequency is within the acceptable range. If yes, please check the AC circuit breaker and AC wiring of the inverter.</p> <p>If the grid voltage/frequency is NOT within the acceptable range and AC wiring is correct, but the alarm occurs repeatedly, contact technical support to change the grid over-voltage, under-voltage, over-frequency, under-frequency protection points after obtaining approval from the local electrical grid operator.</p>
002	GridUVP	The voltage of the mains is too low	
003	GridOFP	The mains frequency is too high	
004	GridUFP	The mains frequency is too low	
005	GFCI	Charge Leakage Fault	Check for inverter and wiring.
008	IslandFault	Island protection fault	<p>If the alarm occurs occasionally, the possible cause is that the electric grid is abnormal occasionally. Inverter will automatically return to normal operating status when the electric grid's back to normal.</p> <p>If the alarm occurs frequently, check</p>
009-010	GridOVPIstant1/2	Transient overvoltage of mains voltage 1/2	





ID	Code Name	Description	Solution
011	VGridLineFault	Power grid line voltage error	whether the grid voltage/frequency is within the acceptable range. If yes, please check the AC circuit breaker and AC wiring of the inverter. If the grid voltage/frequency is NOT within the acceptable range and AC wiring is correct, but the alarm occurs repeatedly, contact technical support to change the grid over-voltage, under-voltage, over-frequency, under-frequency protection points after obtaining approval from the local electrical grid operator.
012	InvVoltFault	Inverter overvoltage	Internal faults of inverter, switch OFF inverter, wait for 5 minutes, then switch ON inverter. Check whether the problem is solved. If no, please contact technical support.
013	RefluxFault	Feed-in Limit function is faulty	Internal error of the inverter. Switch off the inverter, wait 5 minutes and then switch the unit on again. If the error persists, contact technical support.
016	GridPhaseMutation	Grid Phase Mutation	Recoverable faults, wait for 5 minutes. Check whether the problem is solved. Or switch off the inverter, wait 5 minutes and then switch the unit on again. If the error persists, please contact technical support.
017	HwADerrIGrid	Grid current sampling error	
018	HwADerrDCI (AC)	DCI sampling error (AC)	
019	HwADerrVGrid(DC)	Network voltage sampling error (DC)	





ID	Code Name	Description	Solution
020	HwADerrVGrid(AC)	Network voltage sampling error (AC)	
021	HwGFCIFault(DC)	GFCI sampling error (DC)	
024	HwADerrIdc	Input current sampling error	
029	ConsistentGFCI	Leakage current consistency error	
030	ConsistentVgrid	Network voltage consistency error	
032	N-PE fault	Neutral ground fault	<p>Internal error of the inverter. Switch off the inverter, wait 5 minutes and then switch the unit on again. If the error persists, contact technical support.</p> <p>Internal faults of inverter. Switch OFF inverter, wait for 5 minutes, then switch ON inverter. Check whether the problem is solved. If no, please contact technical support.</p>
033	SpiCommFault(DC)	SPI communication is fault (DC)	
034	SpiCommFault(AC)	SPI communication is fault (AC)	
035	SChip_Fault	Slave chip error (DC)	
036	MChip_Fault	Master chip error (DC)	
038	InvSoftStartFail	Inverter failed to output	
039	ArcShutdownAlarm	Arc shutdown protection	<p>Recoverable faults, wait for 5 minutes. Check whether the problem is solved. If no, please contact technical support.</p> <p>Internal error of the inverter.</p>





ID	Code Name	Description	Solution
041	RelayFail	Relay detection failure	Internal error of the inverter. Switch off the inverter, wait 5 minutes and then switch the unit on again. If the error persists, contact technical support.
042	IsoFault	Insulation resistance is too low	Check the insulation resistance between the photovoltaic array and ground (ground), if there is a short circuit, the fault should be repaired in time.
043	PEConnectFault	Earth fault	Check the PE conductor for function
044	InputConfigError	Incorrect input mode configuration	Check the input mode (parallel/independent mode) Settings for the inverter. If not, change the input mode.
046	ReversalConnect	The PV is connected reversedly	Check whether the PV wiring is correct.
047	ParallelFault	Master does not exist or is duplicate	Check the parallel mode settings for the inverter. Check whether the wiring is correct.
050	TempErrHeatSink1	Temperature error heat sink 1	For AC inverter, make sure that the inverter NTC cable is properly connected. Make sure the inverter is installed where there is no direct sunlight or other heat source. Please ensure that the inverter is installed in a cool/ well-ventilated place. Ensure the inverter is installed vertically and the ambient temperature is below the inverter temperature limit.
051	TempErrHeatSink2	Temperature error heat sink 2	





ID	Code Name	Description	Solution
059	TempErrInv1	Module 1-3 Temperature protection	For AC inverter, make sure that the inverter NTC cable is properly connected. Make sure the inverter is installed where there is no direct sunlight or other heat source. Please ensure that the inverter is installed in a cool/ well-ventilated place. Ensure the inverter is installed vertically and the ambient temperature is below the inverter temperature limit.
065	BusRmsUnbalance	Asymmetric bus voltage RMS	Internal error of the inverter. Switch off the inverter, wait 5 minutes and then switch the unit on again. If the error persists, contact technical support.
066	BusInstUnbalance	The transient value of the bus voltage is unbalanced	
067	BusUVP	The DC bus voltage is too low during mains connection	
068	BusZVP	The DC bus voltage is too low	
069	PVOVP	The PV input voltage is too high	Check whether the PV series voltage (Voc) is higher than the maximum input voltage of the inverter. If this is the case, adjust the number of PV modules in series. After the correction, the inverter automatically returns to its normal state.
070	BatOVP	Battery overvoltage	Check whether the voltage of the battery is higher than the maximum input voltage of the inverter. If this is the case, adjust the number of battery modules in series.





ID	Code Name	Description	Solution
072	SwBusRmsOVP	Inverter bus voltage RMS Software overvoltage	<p>Internal error of the inverter. Switch off the inverter, wait 5 minutes and then switch the unit on again. If the error persists, contact technical support.</p> <p>Internal error of the inverter. Switch off the inverter, wait 5 minutes and then switch the unit on again. If the error persists, contact technical support.</p> <p>Internal error of the inverter. Switch off the inverter, wait 5 minutes and then switch the unit on again. If the error persists, contact technical support.</p>
073	SwBusIOVP	Inverter bus voltage instantaneous Software overvoltage	
081	SwBatOCP	Software overcurrent protection of the battery	
082	DciOCP	Dci overcurrent protection	
083	SwIOCP	Instantaneous output current protection	
084	SwBuckBoostOCP	BckBst software overcurrent	
085	SwAcRmsOCP	Output RMS current protection	
086	SwPvOCPInstant	PV overcurrent software protection	
088	IacUnbalance	Unbalanced output current	
090	IbalanceOCP	Balanced current protection	
096	EPSLoadShortCircuit	Inverter bus hardware overvoltage	





ID	Code Name	Description	Solution
098	HwBusOVP	Inverter bus hardware overvoltage	<p>Internal error of the inverter. Switch off the inverter, wait 5 minutes and then switch the unit on again.</p> <p>If the error persists, contact technical support.</p> <p>Internal error of the inverter. Switch off the inverter, wait 5 minutes and then switch the unit on again.</p> <p>If the error persists, contact technical support.</p>
100	HwBatOCP	Battery hardware overflow	
102	HwPVOCP	PV hardware overflows	
103	HwACOCP	Mains current is too high and has triggered hardware protection	
105	MeterComm Fault	Communication fault with meter unit	Check whether the meter is connected correctly.
110-112	Overload1-3	Overload protection 1-3	Please check whether the inverter is operating under overload.
121	SpdFail(DC)	Lightning protection fault (DC)	<p>Recoverable faults, wait for 5 minutes. Check whether the problem is solved. Or switch off the inverter, wait 5 minutes and then switch the unit on again.</p> <p>If the error persists, please contact technical support.</p>
122	SpdFail(AC)	Lightning protection fault (AC)	





ID	Code Name	Description	Solution
145	USBFault	Device cannot read data from USB stick. The USB stick has been damaged. Or the format of the USB stick is not compatible with the device.	Switch off the inverter, wait 5 minutes and then switch the unit on again. If the error persists, contact technical support.
147	BluetoothFault	The device's Bluetooth communication has failed	Switch off the inverter, wait 5 minutes and then switch the unit on again. If the error persists, contact technical support.
150	FlashFault	Communication board FLASH error	Switch off the inverter, wait 5 minutes and then switch the unit on again. If the error persists, contact technical support.
151	BatPartOffline	A portion of the battery's communication is lost	Switch off the inverter, wait 5 minutes and then switch the unit on again. If the error persists, check the communication line or the connection of the battery and the inverter for errors.
152	SafetyVerFault	The safety version is inconsistent with the internal safety version	Check whether safety regulations comply with local standards and import correct safety parameters.
153	SCILose(DC)	SCI communication error (DC)	Upgrade software





ID	Code Name	Description	Solution
154	SCILose(AC)	SCI communication error (AC)	Upgrade software
156	SoftVerError	Inconsistent software versions	Download the latest firmware from the website and launch the software update. If the error persists, contact technical support.
157	BMS1-CommFault	Lithium battery 1 communication error	Make sure your battery is compatible with the inverter. CAN communication is recommended. Check the communication line or the connection of the battery and the inverter for errors.
162	RemoteShutdown	Remote shutdown	The inverter is shut down remotely.
163	Drms0Shutdown	DRM 0 shutdown	The inverter is running with a Drms0 shutdown.
169-174	FanFault1-6	Fan failure1-6	Switch off the inverter, wait 5 minutes and then switch the unit on again. If the error persists, contact technical support.
177	BMS OVP	BMS overvoltage alarm	Internal error in the connected lithium battery. Switch off the inverter and the lithium battery, wait 5 minutes and then switch the components on again. If the error persists, contact technical support.
178	BMS UVP	BMS Undervoltage alarm	
179	BMS OTP	BMS High temperature warning	
180	BMS UTP	BMS low temperature warning	
181	BMS OCP	BMS overload warning during charging and discharging	





ID	Code Name	Description	Solution
186	BatDischarge HTP	BAT High temperature warning when discharging.	Internal error in the connected lithium battery. Switch off the inverter and the lithium battery, wait 5 minutes and then switch the components on again. If the error persists, contact technical support.
187	BatDischarge LTP	BAT low temperature warning when discharging.	Internal error in the connected lithium battery. Switch off the inverter and the lithium battery, wait 5 minutes and then switch the components on again. If the error persists, contact technical support.
188	BatChargeHTP	BAT High temperature warning when charging.	Internal error in the connected lithium battery. Switch off the inverter and the lithium battery, wait 5 minutes and then switch the components on again. If the error persists, contact technical support.
189	AFCICommLoss	AFCI communication error	Please ensure proper installation of the AFCI breaker.
190	BatChargeLTP	BAT low temperature warning when charging.	Internal error in the connected lithium battery. Switch off the inverter and the lithium battery, wait 5 minutes and then switch the components on again. If the error persists, contact technical support.
325	DCRelayFault	Direct-current relay Fault	Switch off the inverter, wait 5 minutes and then switch the unit on again. If the error persists, contact technical support.





ID	Code Name	Description	Solution
328	AcStartTimeOut	BAT active failed.	Internal error in active lithium battery. Check the power line and CAN line between inverter and battery, and then try again. If the error persists, please contact technical support
379	AFCICheckError	AFCI chip self-test abnormality	Switch off the inverter, wait 5 minutes and then switch the unit on again. If the error persists, contact technical support.
401	AFCIO	Arcing detected in AFCI channel	Switch off the inverter, wait 5 minutes and then switch the unit on again. If the error persists, contact technical support.

9.2.2 Battery error list

ID	Name	Description	Solution
864	HS1OverTempFault	Over temperature protection of radiator 1	Power off and wait for 2 hours. If the problem is not solved, please contact technical support.
865	OverTempFault_Env	Over temperature protection of ambient temperature	
868	Relay1Fail	Relay 1 is fault	
871	Relay2Fail	Relay 2 is fault	
872	SwBusInstantOVP	Bus software overvoltage	If this fault occurs occasionally, wait a few minutes to see whether the problem is solved. If this fault occurs frequently, please contact technical support.
874	SwBatInstantOVP	Battery software overvoltage	
876	SwBatInstantOCP		
893	unrecoverBusSCP	Permanent short-circuit protection	Restart the battery and wait for minutes. If the problem is not resolved, please contact technical support.





ID	Name	Description	Solution
895	unrecoverBusRPP	Permanent bus reverse connection	Check whether the wiring is correct and restart the battery. If the problem is not resolved, please contact technical support.
899	BMSOVOCP	BMS overvoltage and overcurrent fault	If this fault occurs occasionally, wait a few minutes to see whether the problem is solved. If this fault occurs frequently, please contact technical support.
900	SwBatAvgOCP	Battery average overcurrent protection	
903	SwCBCOCP	Software CBC overcurrent protection	
905	StartupBusSCP	Start up short circuit protection	Restart the battery and wait for minutes, Check if the power line is short circuited, If the problem is not resolved, please contact technical support.
908	PCScanCommFault	Faulty CAN communication between battery and inverter	Make sure your battery is compatible with the inverter. CAN communication is recommended. Check the communication line or the connection of the battery and the inverter for errors.
911	ADOffsetCalibrateFault	Sample Offset Calibration Failure	Restart the battery and wait for minutes. If the problem is not resolved, please contact technical support.





9.3 Maintenance

Inverters do not generally require daily or routine maintenance. Before carrying out cleaning, ensure that the PV switch and AC circuit breaker between the inverter and power grid have been switched off. Wait at least 5 minutes before carrying out cleaning.

9.3.1 Cleaning the inverter

Clean the inverter using an air blower and a dry, soft cloth or a soft bristle brush. Do NOT clean the inverter with water, corrosive chemicals, cleaning agents etc.

9.3.2 Cleaning the heat sink

In order to help guarantee correct long-term operation of the inverter, make sure that there is sufficient space for ventilation around the heat sink. Check the heat sink for blockages (dust, snow etc.) and remove them if present. Please clean the heat sink using an air blower and a dry, soft cloth or a soft bristle brush. Do NOT clean the heat sink with water, corrosive chemicals, cleaning agents etc.





10 Technical Data

- The following parameters may change without notice, please refer to the user manual and Datasheet on our website.

Model	AZZURRO 3PH HYD 30000 ZSR	AZZURRO 3PH HYD 40000 ZSR	AZZURRO 3PH HYD 50000 ZSR		AZZURRO 3PH HYD 60000 ZSR
PV input					
Recommended Max. PV Power	60kWp	80kWp	100kWp		120kWp
Max. Input Voltage	1000Vd.c.				
Start-up Voltage[1]	200Vd.c.				
Rated Input Voltage	600Vd.c.				
MPP Voltage Range	160-950 Vd.c.				
Number of MPPT	4				
Max. Number of Input Strings per MPPT	2/2/2/2				
Max. Input Current	40A/40A/40A/40A				
Max. Isc	50A/50A/50A/50A				
Battery					
Voltage Range	600-1000 Vd.c.				
Number of Battery Input Channels	1				
Max. Charging Power	60 kW				
Max. Discharging Power	30 kW	40 kW	49.9 kW	50 kW	60 kW
Max. Charging Current	100 A				
Max. Discharging Current	48 A	64 A	79.8 A	80 A	100 A
Battery Type[2]	Lithium-ion				
BMS Communication	CAN				
AC Backup					
Rated Output Voltage	3N~+PE,380/400/415 Va.c.				
Rated Output Frequency	50/60 Hz				



Model	AZZURRO 3PH HYD 30000 ZSR	AZZURRO 3PH HYD 40000 ZSR	AZZURRO 3PH HYD 50000 ZSR	AZZURRO 3PH HYD 60000 ZSR
Rated Output Power	30kW	40 kW	50 kW	60 kW
Rated Output Current	45,6/43,3/41,7 A	60.8/57.7/55.6 A	76.0/72.2/69.6 A	91.2/86.6/83.5 A
Rated Apparent Power	30 KVA	40 kVA	50 kVA	60 kVA
Max. Apparent Power	33 kVA	44 kVA	55 kVA	66 kVA
Max. Output Current	50,1/47,6/45,9 A	66.9/63.5/61.2 A	83.6/79.4/76.5 A	100/95.3/91.8 A
Peak Output Apparent Power [3]	1.5 times of rated power, 10s			
THDv(@ linear load)	<3%			
Switching Time [4]	4 ms			
Asymmetric load	Yes, Supports 100% three-phase unbalanced load			
AC Smartload/Generator				
Rated Output Voltage	3N~+PE,380/400/415 Va.c.			
Rated Output Frequency	50/60 Hz			
Rated Output Power	30 kW	40 kW	50 kW	60 kW
Rated Output Current	45,6/43,3/41,7 A	60.8/57.7/55.6 A	76.0/72.2/69.6 A	91.2/86.6/83.5 A
Rated Apparent Power	30 kVA	40 kVA	50 kVA	60 kVA
Max. Apparent Power	33 kVA	44 kVA	55 kVA	66 kVA
Max. Output Current	50,1/47,6/45,9 A	66.9/63.5/61.2 A	83.6/79.4/76.5 A	100/95.3/91.8 A
AC Grid				
Rated Voltage	3(N)~+PE,380/400/415 Va.c.			
Rated Frequency	50/60 Hz			
Rated Output Power	30 kW	40 kW	50 kW	60 kW
Rated Output Current	45,6/43,3/41,7 A	60.8/57.7/55.6 A	76.0/72.2/69.6 A	91.2/86.6/83.5 A
Rated Apparent Power	30 kVA	40 kVA	50 kVA	60 kVA
Max. Apparent Power	33 kVA	44 kVA	55 kVA	66 kVA
Max. Output Current	50,1/47,6/45,9 A	66.9/63.5/61.2 A	83.6/79.4/76.5 A	100/95.3/91.8 A





Model	AZZURRO 3PH HYD 30000 ZSR	AZZURRO 3PH HYD 40000 ZSR	AZZURRO 3PH HYD 50000 ZSR	AZZURRO 3PH HYD 60000 ZSR
Max. Input Current	100 A			
THDi	<3%			
Power Factor Range	0.8 lagging-0.8 leading			
Efficiency				
Max. MPPT Efficiency	99.9%			
Max. Efficiency	98,0%	98.2%	98.2%	98.2%
European Efficiency	97,0%	97.5%	97.5%	97.5%
Max. Efficiency of Charging/Discharging [5]	98,0%	98.2%	98.2%	98.2%
Protection				
PV Switch	Yes			
PV Reverse Connection Protection	Yes			
Battery Reverse Connection Protection	Yes			
Output Short Circuit Protection	Yes			
Output Overcurrent Protection	Yes			
Output Overvoltage Protection	Yes			
Insulation Impedance Detection	Yes			
Residual Current Detection	Yes			
Anti-island Protection	Yes			
Surge Protection	PV:Type I+II, AC:Type II			
General Parameters				
Inverter Topology	Non-Isolation			
Protective Class	Class I			
IP Rating	IP66			
Overvoltage Category	AC III, DC II			





Model	AZZURRO 3PH HYD 30000 ZSR	AZZURRO 3PH HYD 40000 ZSR	AZZURRO 3PH HYD 50000 ZSR	AZZURRO 3PH HYD 60000 ZSR
Operating Temperature Range	-30°C to +60°C (derating above +45°C)			
Relative Humidity Range	5%-95%			
Max. Operating Altitude	4000 m (derating above 2000 m)			
Standby Self-consumption [7]	<15 W			
Installation Method	Wall Mounted			
Dimensions(W*H*D)	850*660*305 mm			
Cooling Mode	Intelligent Airflow			
Weight	75 kg			
Communication	RS485, Optional: WiFi/4G/LAN			
Display	LCD & APP			

[1] Minimum PV voltage to start MPPT operation.

[2] Please refer to document “Zucchetti Centro Sistemi Spa inverter Model compatible battery list”.

[3] Full sun.

[4] In the on-grid mode, the nominal power of the hybrid inverter is higher than the total power of the home loads.

[5] Battery-AC maximum efficiency of battery charge and discharge.

[6] According to EN/IEC 61643-11.

[7] Standby loss at rated input voltage.

Depending on the type of installation, the following kits are available:

- ✓ Energy Storage Cabinet (A) ZZT-POWER-MINI-KIT
- ✓ Energy Storage Cabinet (B) ZZT-POWER-MINI-KIT-20M
- ✓ Energy Storage Cabinet (C) ZZT-POWER-MINI-KIT-100M
- ✓ Energy Storage Cabinet (E) ZZT-POWER-MINI-FIX
- ✓ Energy Storage Cabinet (F) ZZT-POWER-MINI-KIT-PAR
- ✓ Steel Base ZZT-BASE-POWER-MINI

For further details, please refer to Chapter 6.4 “Delivery Inspection” of this manual.



11 Uninstalling

11.1 Uninstallation steps

- Disconnect the inverter from the AC grid.
- Disconnect the DC switch (located on the battery or installed on the wall)
- Wait 5 minutes
- To remove the DC connectors from the inverter
- Remove the connectors for communication with the batteries, current sensors and NTC temperature probe.
- Remove the AC terminals.
- Unscrew the fixing bolt of the bracket and remove the inverter from the wall.

11.2 Packaging

If possible, pack the product in its original packaging.

11.3 Storage

Store the inverter in a dry place where the ambient temperature is between -25 and +60°C.

11.4 Disposal

Zucchetti Centro Sistemi S.p.a. is not liable for the disposal of the equipment, or parts thereof, that does not take place according to the regulations and standards in force in the country of installation.



The symbol of the crossed-out wheeled bin indicates that the equipment, at the end of its useful life, must be disposed of separately from household waste.

This product must be handed over to the waste collection point in your local community for recycling.

For more information, please contact the waste collection authority in your country.

Inappropriate waste disposal could have negative effects on the environment and on human health due to potentially hazardous substances.

With your cooperation in the correct disposal of this product, you contribute to the reuse, recycling and recovery of the product, and to the protection of our environment.

12 Warranty terms and conditions

To view the Warranty Terms and Conditions” offered by ZCS Azzurro, please refer to the documentation inside the product box and on the website www.zcsazzurro.com.



zcsazzurro.com



Zucchetti Centro Sistemi S.p.A.
Green Innovation Division
Palazzo dell'Innovazione - Via Lungarno, 167
52028 Terranuova Bracciolini - Arezzo, Italy
zcscompany.com

