

# EV CHARGER DC POWER ZVD-60K-POWER ZVD-120K-POWER User Manual



## General instructions

This manual contains important safety instructions that must be followed during installation and maintenance of the equipment.

## Please keep these instructions!

This manual must be considered an integral part of the equipment, and must be available at all times to everyone who interacts with the equipment. The manual must always accompany the equipment, even when it is transferred to another user or plant.

## Copyright statement

Copyright of this manual belongs to Zucchetti Centro Sistemi S.p.A. No part of this manual may be copied (including the software), reproduced or distributed in any form or by any means without the permission of Zucchetti Centro Sistemi S.p.A. All rights reserved. ZCS reserves the right to final interpretation. This manual is subject to change based on feedback from users, installers or customers. Please check our website at <http://www.zcsazzurro.com> for the latest version.

## Technical support

ZCS offers a support and technical consultancy service accessible by sending a request directly from the website [www.zcsazzurro.com](http://www.zcsazzurro.com)

The following toll-free number is available for the Italian territory: 800 72 74 64.

# Table of Contents

1. Preliminary safety instructions .....	6
1.1. Safety instructions .....	6
1.2. Symbols and icons.....	12
1.3. Labels .....	13
2. Product Overview.....	14
2.1. Product Introduction .....	14
2.2. Inside view .....	15
3. Installation.....	16
3.1. Checks before installation.....	16
3.1.1. Installation tools .....	19
3.1.2. Cables & Materials .....	20
3.1.3. Movement of the charger .....	21
3.2. Prepare tools.....	21
3.3. Prepare cable .....	21
3.4. Prepare cable lug .....	22
3.4.1. Recommended sizes for installation.....	23
3.4.2. Prepare concrete foundation.....	25
4. Installation.....	26
4.1. Preparation .....	26
4.2. Installation .....	27
4.3. Wiring.....	30
4.3.1. Connect power cable .....	30
4.3.2. Connect communication cable .....	31
5. Disposal .....	32
6. Commissioning .....	33
6.1. Configure the network for the charger.....	33
6.2. Connect charger to Evcharge Cloud Portal.....	36
7. Operations.....	37
7.1. Indicator description.....	37

7.2.	LCD information .....	37
7.3.	Checks before initial startup .....	40
7.4.	Checks before switching on for the first time .....	41
7.5.	Checks when switching on for the first time .....	41
8.	Operation Instruction .....	42
8.1.1.	Start Charging .....	42
8.1.2.	Start Charging .....	42
8.1.3.	Stop Charging .....	42
8.1.4.	Charger Setting .....	42
9.	Appendix-Working principle diagram for ZVD-120K-POWER .....	43
10.	Appendix-Working principle diagram for ZVD-60K-POWER .....	44
11.	LED Indicator .....	45
12.	Technical datasheet .....	46
13.	Troubleshooting and maintenance .....	47
13.1.	Troubleshooting .....	47
13.2.	Maintenance .....	51
14.	Dismantling and disposal .....	54
15.	Warranty .....	55

## Preface

### General information

Please read this manual carefully before installation, use or maintenance. This manual contains important safety instructions that must be followed during installation and maintenance of the system.

### Scope

This manual describes the assembly, installation, electrical connection, commissioning, maintenance and troubleshooting of the DC-030K-E2C22-75:





Keep this manual so that it is accessible at all times.

### Recipients

This manual is intended for qualified technical personnel (installers, technicians, electricians, technical support personnel or anyone who is qualified and certified to work on an electrical system), responsible for installing, starting up and operating the charging station.

### Symbols used

This manual provides information for safe operation and uses certain symbols to ensure the safety of personnel and materials, and for efficient use of the equipment during normal operation. It is important to understand this information to avoid accidents and damage to property. Please take note of the following symbols used in this manual.

	<b>Danger: indicates a hazardous situation which, if not resolved or avoided, could result in serious personal injury or death</b>
<b>Danger</b>	
	<b>Warning: indicates a hazardous situation which, if not resolved or avoided, could result in serious personal injury or death</b>
<b>Warning</b>	
	<b>Caution: indicates a hazardous situation which, if not resolved or avoided, could result in minor or moderate personal injury</b>
<b>Caution</b>	
	<b>Attention: indicates a potentially hazardous situation which, if not resolved or avoided, could result in damage to the system or other property</b>
<b>Attention</b>	



Note

**Note: provides important tips on the correct and optimal operation of the product**

## 1. Preliminary safety instructions



Note

**If you have problems or questions in reading and understanding the following information, please contact Zucchetti Centro Sistemi S.p.A. through the appropriate channels.**

### 1.1. Safety instructions

Highlights the safety instructions to be followed during installation and use of the equipment.

Before installing and using the equipment, make sure you read and understand the instructions in this manual and familiarise yourself with the relative safety symbols shown in this chapter. According to national and local requirements, permission must be obtained from your local provider before connecting to the electrical grid, making sure that the connections are carried out by a qualified electrician. All installation work must be carried out by a qualified and competent electrician.

Contact the nearest authorised service centre for any repairs or maintenance. Contact your distributor for information on the nearest authorised service centre. **DO NOT** carry out repairs yourself, as this may result in injury or damage.

#### Qualified personnel

Ensure that the operator has the necessary skills and training to operate the equipment. Personnel responsible for use and maintenance of the equipment must be qualified and capable of performing the activities described, and must also have appropriate knowledge on how to correctly interpret the contents of this manual. For safety reasons, this charging station can only be installed and serviced by a qualified electrician with the necessary training and/or skills and knowledge. Zucchetti Centro Sistemi S.p.A. declines all responsibility for damage to property or personal injury caused by incorrect use of the device.

Do not attempt in any way to repair or replace components of the charging station without the assistance of qualified personnel.

#### Installation requirements

Install and start the charging station according to the following instructions. Place the charging station on suitable load-bearing supports with sufficient load capacity (such as metal walls or columns) and make sure it is positioned vertically. Choose a suitable location for the installation of the electrical equipment. Make sure there is sufficient space for heat dispersion and to accommodate future maintenance. Maintain adequate ventilation and ensure that there is enough air circulation for cooling. The charging station display must not be exposed directly to sunlight.

Follow the instructions in this manual exactly.

Only perform any services as installation engineer or use the DC charger when you are fully qualified to do so.

Observe the instructions in this manual and any applicable local laws. If the local laws contradict with the instructions in this manual, the local laws will be applied. In the case of any conflict or contradiction between any requirements or procedure contained in this manual and any such local laws and/or rules, obey the local laws and/or rules, requirements, and processes established in this manual, if and to the degree permitted by law.

Be familiar with and follow all applicable laws and regulations.

Before working, identify the dangers and conduct a risk assessment resulting from the working circumstances on the site.

To use the DC charger with the protective devices in place.

Ensuring that all protective devices are properly installed following installation or maintenance work.

To create an emergency plan that informs people on what to do in the case of an DC Charger or other site emergency.

Ensuring that all employees, the owner, and third parties are qualified to conduct the work in accordance with applicable local laws and/or norms.

Ensuring that there is enough room around the DC Charger to safely perform maintenance and installation tasks.

The qualified installation engineer should be completely familiar with the DC Charger and its safe installation.

The installation engineer should be qualified to do the work in accordance with the applicable local regulations.

The qualified installation engineer should follow all local rules as well as the installation methods outlined in this manual.

Ensure that there is no voltage on the AC input side throughout the installation process.

Keep unqualified personnel a safe distance away from the installation.

Use only electrical cables with the proper gauge and insulation to handle the rated current and voltage demand.

Ensure that the grid's load capacity corresponds to the DC Charger.

Ensure that the wiring within the DC Charger is not damaged and cannot become caught when the cabinet is opened or closed.

Make certain that no water can enter the cabinet.

Protect the DC Charger with the safety equipment and procedures specified by local regulations.

If it is necessary to remove safety equipment, replace them as soon as possible once the work is completed.

Wear the appropriate personal protective equipment (PPE).



Do not use the DC Charger and immediately get in contact with the manufacturer if the safety or the safe use of the DC Charger is at risk. This includes, but is not limited to, these conditions: the enclosure has damage, the EV charge cable or connector has damage, lightning struck the DC Charger, there was an accident or a fire at or near the DC Charger, water entered the DC Charger.

Make sure that the DC Charger is connected to a grounded, metal, permanent wiring system, or an equipment-grounding conductor must be run with the circuit conductors and connected to the equipment grounding terminal or lead on the product.







Make sure that the connections to the DC Charger comply with all applicable local rules.

Adapters or conversion adapters are not allowed to be used.

The charging station display must not be exposed directly to sunlight.

	<p><b>Keep the charger away from inflammable, chemicals, vapors and other hazard materials.</b></p>
<p><b>Danger</b></p>	
	<p><b>Keep the charging connector clean and dry. Clean it with clean dry rag in case it's wet or dirty.</b></p>
<p><b>Danger</b></p>	
	<p><b>In case any Malfunction or exception, please press the emergency stop button immediately, and cut off all input and output power supplies.</b></p>
<p><b>Danger</b></p>	



 <b>Danger</b>	<p>Do not use the charger in case the product has defects, crack, abrasion, bare leakage and so on. Please contact the working staff in case of above conditions.</p>
 <b>Danger</b>	<p>Please do not attempt to disassemble, repair, or modify the charger. If there is a need for maintenance or modification, please contact the aftersale service. Improper operation may cause equipment damage, water leakage, electric leakage, etc.</p>
 <b>Danger</b>	<p>For the safety of human and the vehicle, it is strictly forbidden to pull out the charging connector during the charging process.</p> <p>If there is any abnormality during use, press emergency button immediately to cut off all input and output power.</p>
 <b>Danger</b>	<p>Pay extra attention while charging in raining or lighting weather.</p>
 <b>Danger</b>	<p>Children are forbidden to approach or use the charger to avoid any injury.</p>
 <b>Danger</b>	<p>The EV has to be stopped while charging, charging only when the EV stops still. Charging the hybrid EV only when its engine is switched off.</p>



 <b>Warning</b>	<p>The input and output voltages of this product are dangerous high voltage, which can endanger human life safety. Please strictly observe all warnings and operating instructions on the product and in the manual. Unauthorized and non-professional service personnel should not remove the cover of this product.</p>	 <b>Warning</b>
---	---	---





Figure 1 - Do not lose or damage this manual

## Transport requirements

If you encounter problems with the packaging that could damage the charging station or if you find any visible damage, immediately notify the transport company. If necessary, request assistance from an installer or from Zucchetti Centro Sistemi S.p.A. Transport of the equipment, especially by road, must be carried out with vehicles suitable to protect the components (in particular, electronic components) against violent knocks, humidity, vibrations, etc.

## Electrical connections



Please follow all the electrical regulations on accident prevention.

	<b>Before connecting the electrical cables, make sure to properly disconnect the voltage on the AC connection cables, and do not connect any charging cables for electric vehicles.</b>
<b>Danger</b>	
	<b>All installation operations must be carried out by a professional electrician, who has carefully read this manual and understands its contents!</b>
<b>Warning</b>	
	<b>Before connecting the charging station to the grid, make sure that all the necessary permits have been obtained from the local grid operator and that all the electrical connections have been completed by a professional electrician.</b>
<b>Attention</b>	

	<p><b>Do not remove the information label or tamper with the charging station. Otherwise, ZCS will not provide any warranty or assistance</b></p>
<b>Note</b>	



## Operation

Do not use the product if it has any defects, cracks, scratches or leaks, but contact your dealer or ZCS technical service.

	<p><b>Contact with the electrical grid or the terminal of the equipment may cause electrocution or fire!</b></p> <ul style="list-style-type: none"> <li>Do not touch the terminal or the conductor connected to the electrical grid.</li> <li>Follow all the instructions and safety requirements relating to grid connection</li> </ul>
<b>Danger</b>	
	<p><b>If the charging station is not functioning properly:</b></p> <ul style="list-style-type: none"> <li>Disconnect the input and output power supply</li> </ul>
<b>Warning</b>	
	<p><b>Take special care when charging in thunderstorms or in rain</b></p>
<b>Attention</b>	

## Maintenance and repair

Keep the charging station clean and dry; if you need to clean it, use a clean dry cloth. It is very dangerous to touch the inside of the charging station, therefore it is strictly forbidden to do so while the system is running. NEVER clean the inside of the charging station with a wet or damp cloth.

	<ul style="list-style-type: none"> <li>• Before performing any repairs, disconnect the charging station from the power supply (AC side) and from the data connection to the transmission gate.</li> <li>• After switching off the DC switch, wait 5 minutes before carrying out any repairs or maintenance on the charging station</li> </ul>
Danger	
	<ul style="list-style-type: none"> <li>• The charging station should start working again after any faults have been fixed. For repairs, contact your local authorised service centre</li> <li>• Do not disassemble the internal components of the charging station without permission; this will void the warranty.</li> </ul>
Attention	

## 1.2. Symbols and icons

Introduces the main safety symbols on the charging station. Some safety symbols are located on the charging station. Read and understand the contents of the symbols before installation:





	Be careful of high voltage
	Complies with the European Standards
	Ground connection point
	Read this manual before installing the charging station.
	<p>Degree of protection of the equipment according to the IEC 70- 1 standard (EN 60529 June 1997).</p> <p>IP54 means that it is resistant against water and rust, therefore also suitable for outdoor operation and maintenance.</p>

Table 1 – Symbols present on the charger

### 1.3. Labels



Figure 2 - Labels present on the charging station



**DO NOT** remove the labels. **DO NOT** cover with sheets, supports, cabinets, etc. Always keep them clean and legible.

## 2. Product Overview

### 2.1. Product Introduction

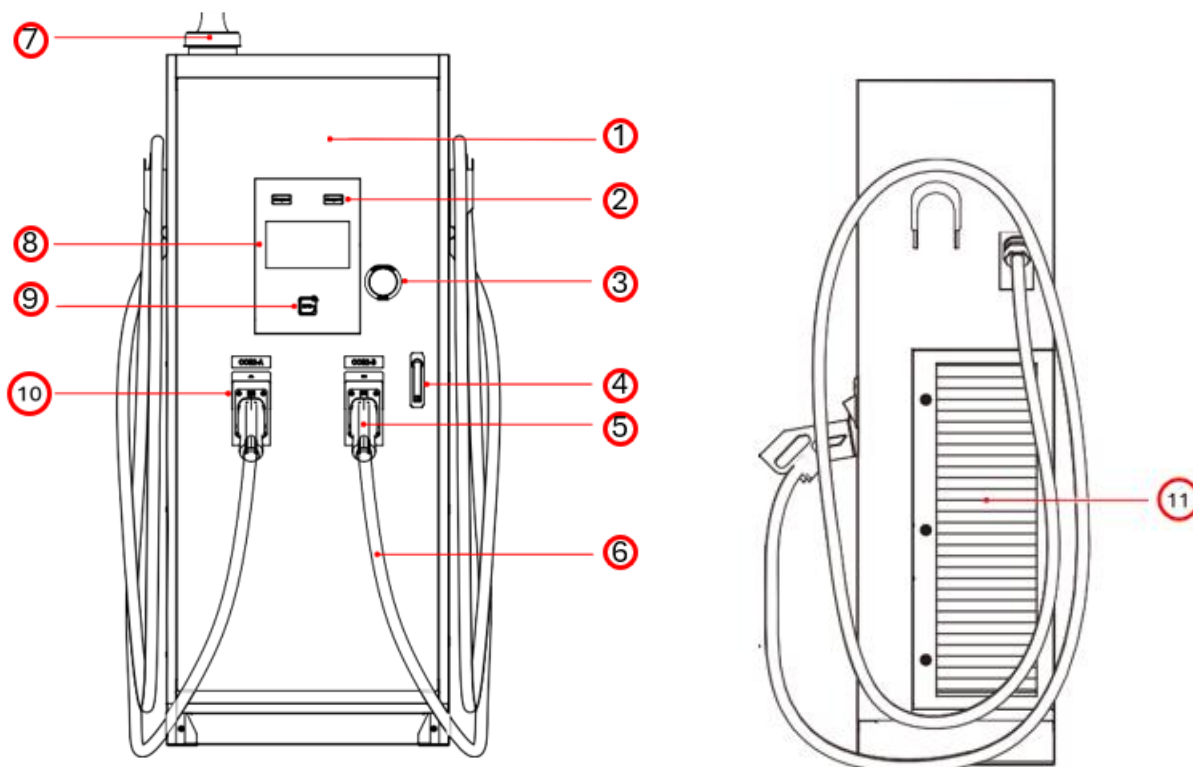
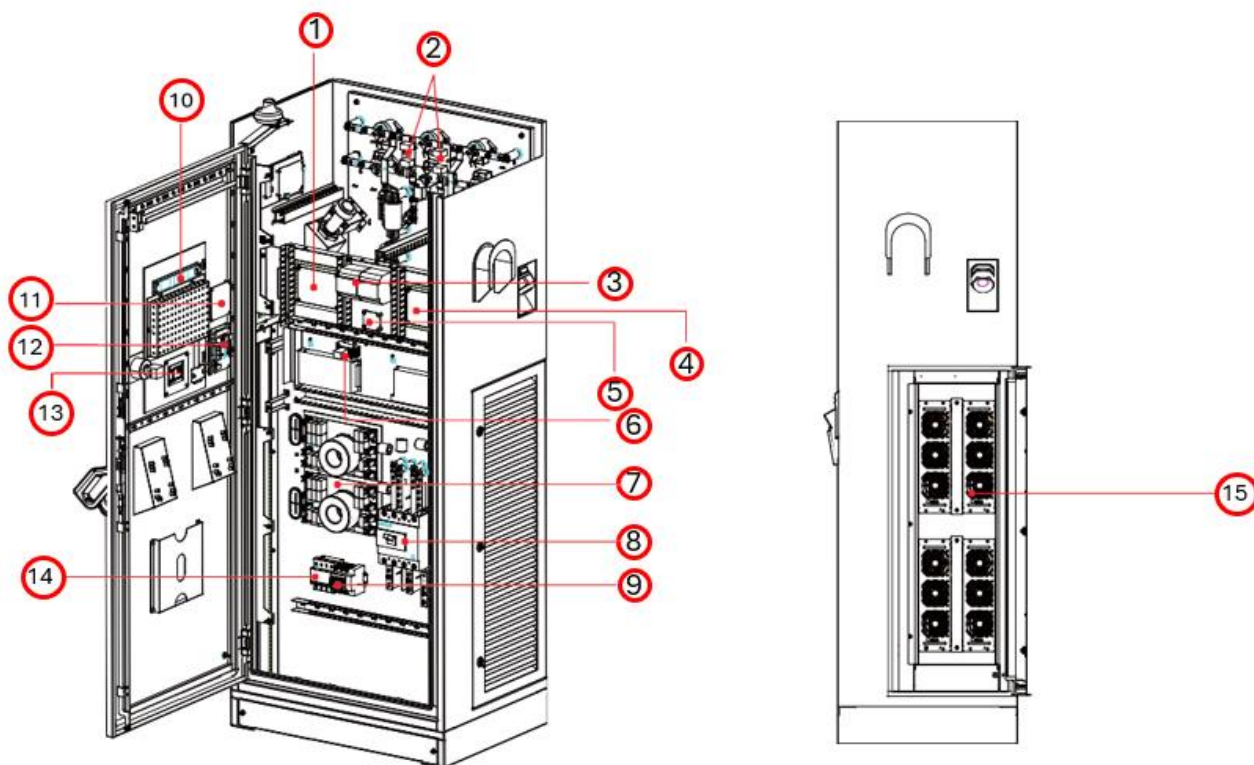

Figure 3 - Detail



1	Logo	7	Antenna
2	LED Indicator	8	LCD display
3	Emergency stop	9	RFID card sensing area
4	Lock	10	Cable holder
5	Charging connector	11	Module
6	Charging cable		

## 2.2. Inside view



1	Control PCB	9	Circuit beaker
2	DC wave filter	10	LED indicator
3	Smart meter	11	Main control PCB
4	Control PCB	12	Gateway
5	Power switching PCB	13	RFID card sensing
6	Relay	14	Lightning protector
7	AC Wave filter	15	Power module
8	Terminal block		

## 3. Installation

	<ul style="list-style-type: none"> <li>• DO NOT install the charging station near flammable materials.</li> <li>• DO NOT install the charging station in an area where flammable or explosive materials are stored.</li> </ul>
<b>Danger</b>	
	<ul style="list-style-type: none"> <li>• Take into account the weight of the charging station during transport and installation.</li> <li>• Choose an appropriate mounting position and surface.</li> </ul>
<b>Attention</b>	

### 3.1. Checks before installation

#### Checking the outer packaging





Packaging materials and components may be damaged during transport. Therefore, it is recommended to check the materials of the outer packaging before installing the charging station. Check the surface of the box for external damage such as holes or tears. If any type of damage is detected, do not open the box containing the charging station and contact the supplier and the courier as soon as possible. It is also recommended that you check the contents of the packaging and make sure that they correspond to what was declared. If not, contact your dealer to have any missing parts sent to you.

#### Checking the product

After removing the charging station from its packaging, check that the product is intact and complete. If any damage is found or components are missing, contact the supplier and transport company.

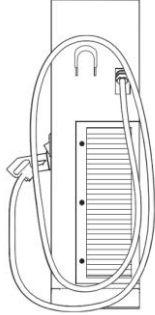
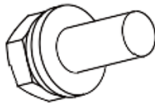

## Contents of the packaging

No.	Part		Qty
1		Charger	1
2		M12 Screw	4
3		RFID card	2
4		Power module	2-4
5		Key for opening the front door	1
6		Key for right door (for adding power modules	1









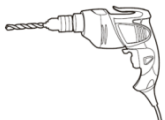

7		Declaration of Conformity	1
8		User Manual	1
9		Warranty	1

Table 2 - Package contents

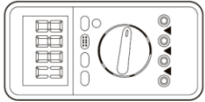

### 3.1.1. Installation tools

The following tools are required for the installation of the charging station and electrical connections; therefore, they must be prepared before installation.

No.	Tool	Function
1	 Cross Screwdriver (PH2x150mm, PH3x250mm)	Tight the screws
2	 Drill	To drill scre holes
3	 Insulated Torque Wrench	Tight the bolts
4	 Insulated Spanner	Tight the bolts and nuts
5	 Combination Wrench	Tight the bolts
6	 Diagonal Pliers	To cutter the cable
7	 Hydraulic Clamp	Clamp OT terminals
8	 Multi-meter	To check the voltage and current values
9	 Marker pen	To mark the wall for better fixing precision



10		Measuring tape	To measure distances
11		Level	To make sure the bracket is level
12		ESD gloves	Protective clothing
13		Safety goggles	Protective clothing

Table 3 – Installation tools

### 3.1.2. Cables & Materials

Name	Specification	Quantity
Power supply cable	$\geq 5 \times 6 \text{mm}^2$ three-phase power supply cable	Depend on actual requirement
Insulated tape	0.15mm*18mm, 0~600V, 0°C~80°C	Depend on actual requirement
Cable tie	4*200mm	Depend on actual requirement

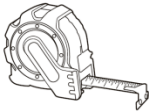
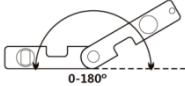
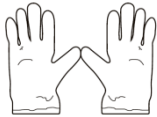
### 3.1.3. Movement of the charger

- 1) Open the packaging and remove the polystyrene protection cover, insert your hands into the slots and take hold of the device;
- 2) Lift the charging station from its packing box and move it to the installation position, then remove the polystyrene protections.

	<ul style="list-style-type: none"> <li>To prevent damage and personal injury, hold the device securely when moving as it is a heavy piece of equipment</li> <li>Always position the device horizontally</li> </ul>
Attention	

### 3.2. Prepare tools

Personal Protective equipment	Safety helmet	Protective gloves	Insulated shoes
<b>Hardware installation tools</b>	Philips insulated torque screwdriver	Insulated security torx torque screwdriver	Hammer drill and drill bit
	Marker	Fork lift	
<b>Cable installation tools</b>	Wire stripper	Crimpling tools	Scissors
<b>Measurement instruments</b>	Clamp meter	Steel measuring tape	Level instrument
<b>Auxiliary materials</b>	Insulation tape	Heat-shrink tubing	

### 3.3. Prepare cable

Cable type	Operating current	Cross-sectional area
<b>AC Input power cable (three-phase five wire)</b>	190A (DC120kW)	95~120mm <sup>2</sup>
	96A (DC (60kW)	50~70mm <sup>2</sup>

It is important that all cables used are suitable for outdoor use

**NOTE:** For safety reasons, make sure to use suitably sized cables, otherwise the current may cause overheating or overloading, which could result in a fire.

### 3.4. Prepare cable lug

Charger	DC120K				DC60K			
Cable Lug	CSA 95mm <sup>2</sup>		CSA120mm <sup>2</sup>		CSA 50mm <sup>2</sup>		CSA70mm <sup>2</sup>	
	A	10.5mm	A	13mm	A	8.4mm	A	10.5mm
	B	46mm	B	48mm	B	40mm	B	12mm
	C	13mm	C	15mm	C	10mm	C	42mm

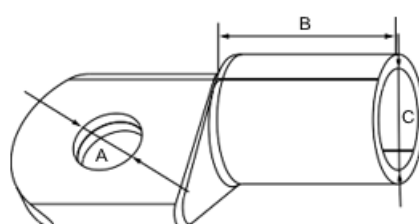

Figure 4 - Cable Lug

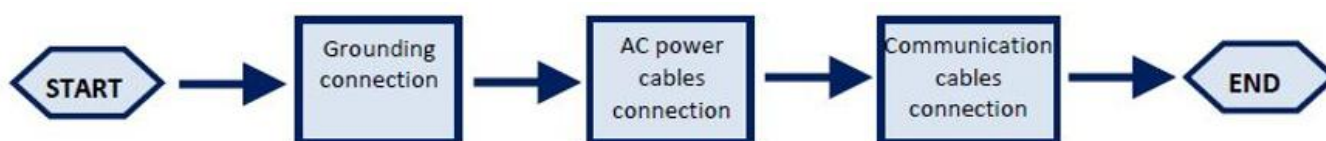
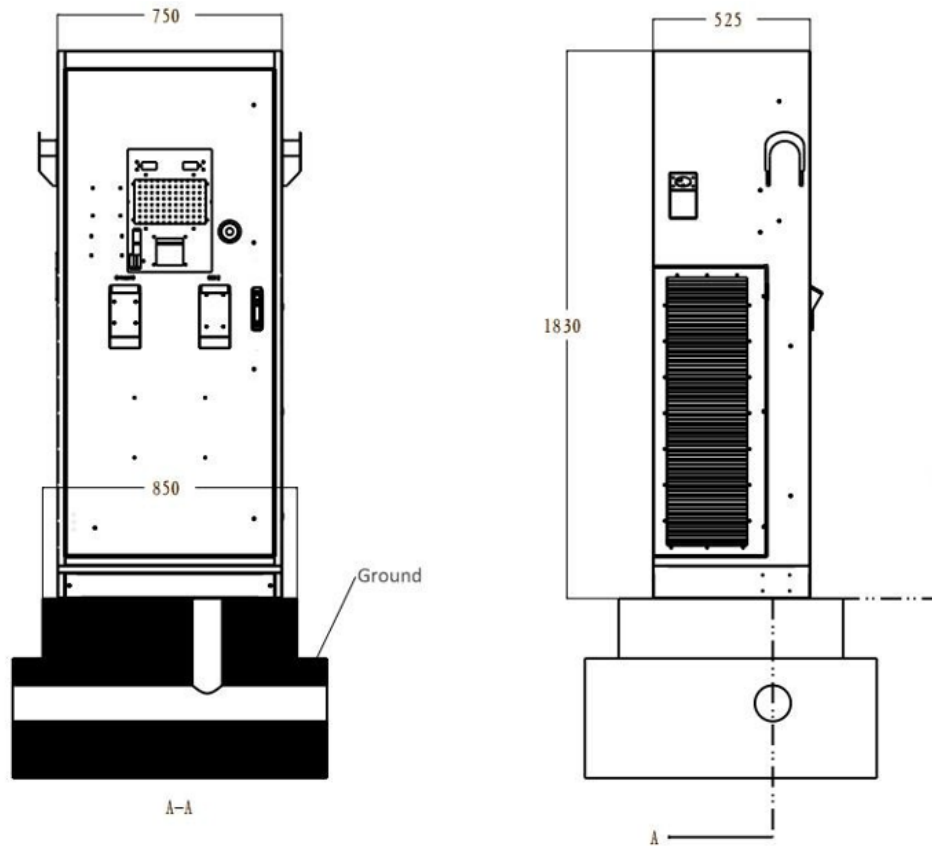

Figure 5 - Logical sequence for connecting cables

### 3.4.1. Recommended sizes for installation

The base shall be built according to the requirements. It is recommended that the base be 200mm higher than the road surface, 100mm larger than the outside of the cabinet for each measurement ratio before, during and after the cabinet, and threading holes shall be reserved.



#### Install Holders

According to the installation size drawing of charging pile base, make bolt holes in the base and the recommended depth is 100mm, the diameter of  $\Phi 16$ mm. The specification of the expansion bolt provided by the manufacturer is M12\*110mm.

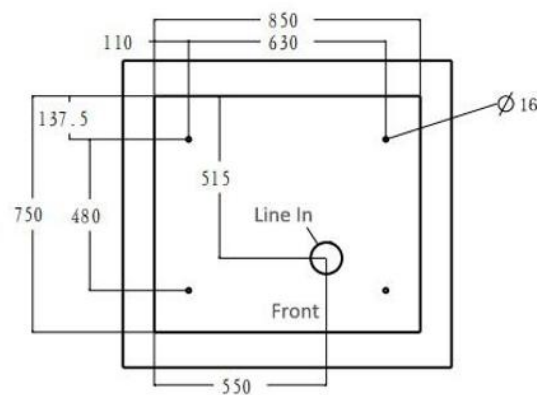

## Connect Cables

The power supply cables go through the input cable inlet at the charger's bottom, and connect to the corresponding L1, L2, L3, N and PE terminals inside the charger. Please note that L1, L2, L3, N correspond to R, S, T, N phases.

## Placement distance

Distance between charger rear and wall  $\geq 0.3$  m, between charger side and wall  $\geq 1.5$  m, and between charger and charger  $\geq 2.0$  m.

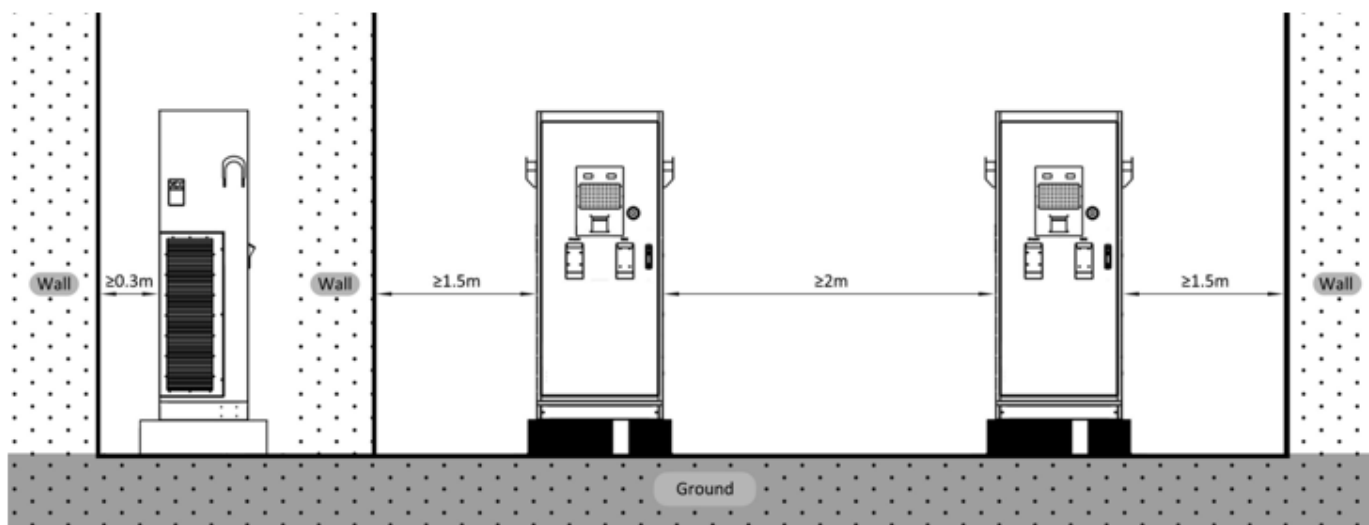



### 3.4.2. Prepare concrete foundation

The concrete foundation is made up of two pieces that are cast in cement and are fixed and joined with steel bars. Please note that the tubular nuts with threads should be embedded while preparing the foundation.

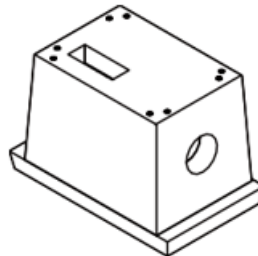

#### Step 1:

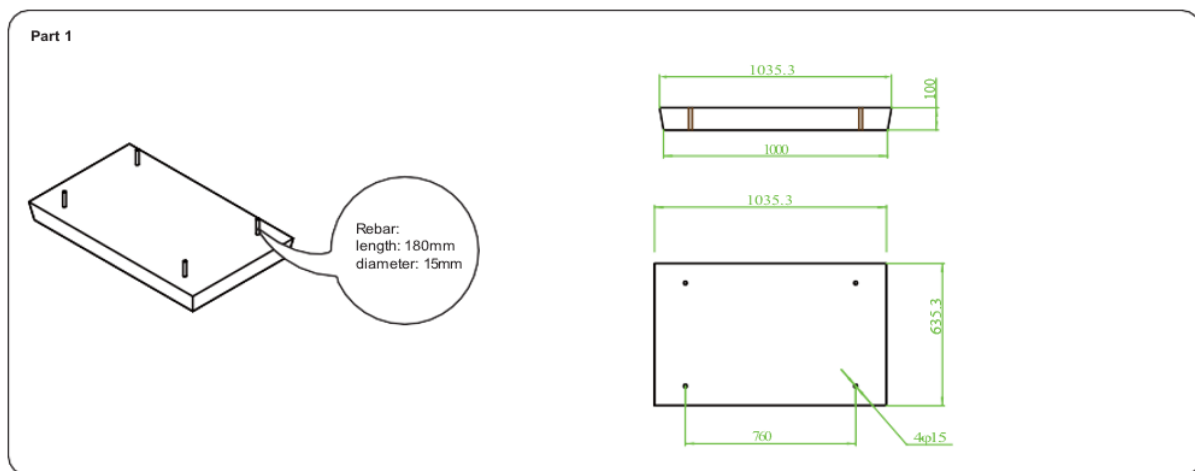

#### Step 2:

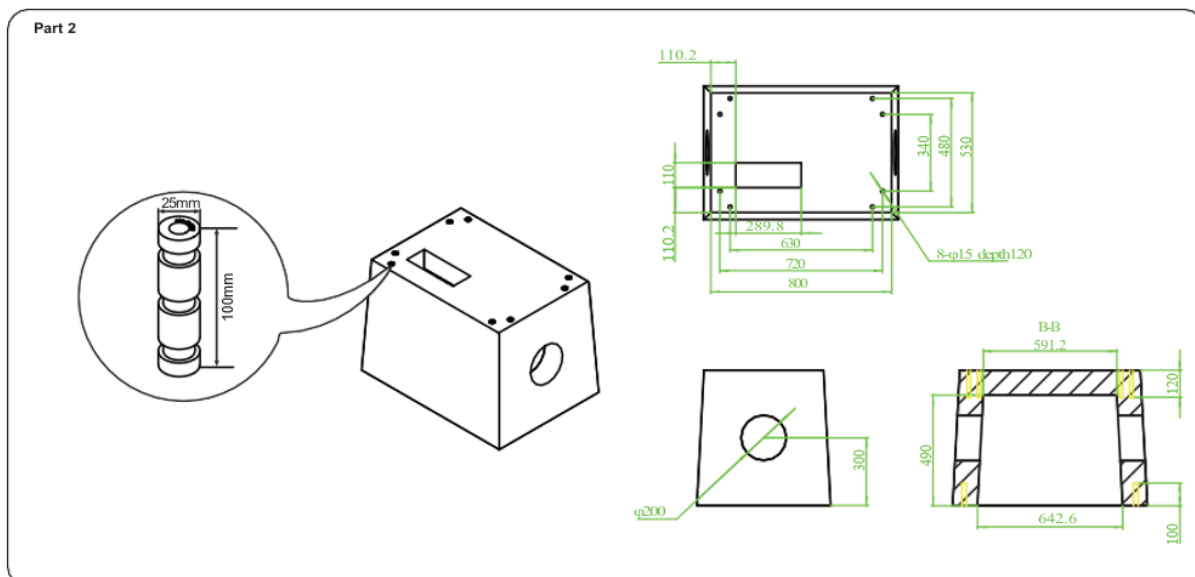

## 4. Installation



**Danger**

- Please disconnect the power supply before proceeding with installation work

### 4.1. Preparation

**Step1:** Electrical product should be installed, operated, serviced, and maintained only by qualified personnel. No responsibility is assumed by the manufacturer for any consequences arising out of the installation of this product.

**Step2:** A qualified person is one who has skills and knowledge related to the construction, installation and operation of electrical product and who has received safety training to recognize and avoid the hazards involved.

**Step3:** All applicable local, regional, and national regulations must be respected when installing, repairing, and maintaining this product.

The schematic diagram for the final installation is as follows. A concrete foundation supports the charger. The concrete foundation body is mostly hidden in the ground. The cables are also buried in the earth and are linked to the charger through the side holes.

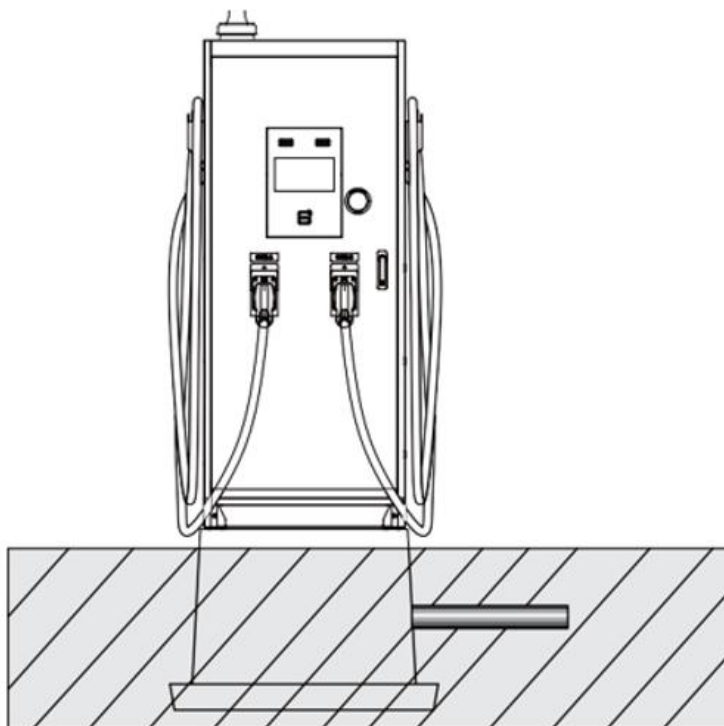

## 4.2. Installation

**Step1:** Loosen the screws that hold the front and rear panels in place at the bottom of the charger to remove the panels.

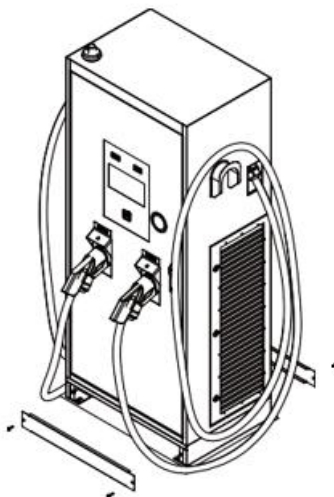

**Step2:** Use the forklift to lift and carry the charger, and place it onto the concrete foundation.

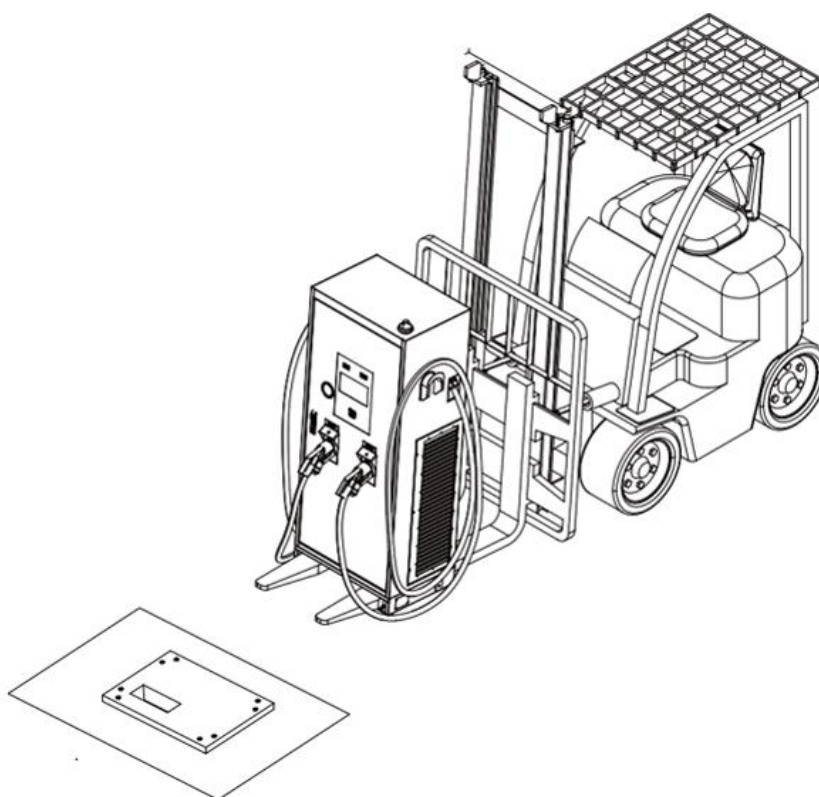

**Step3:** Secure the charger to the concrete foundation with four M12 screws. Place the front and rear panels in place, fasten them with screws.

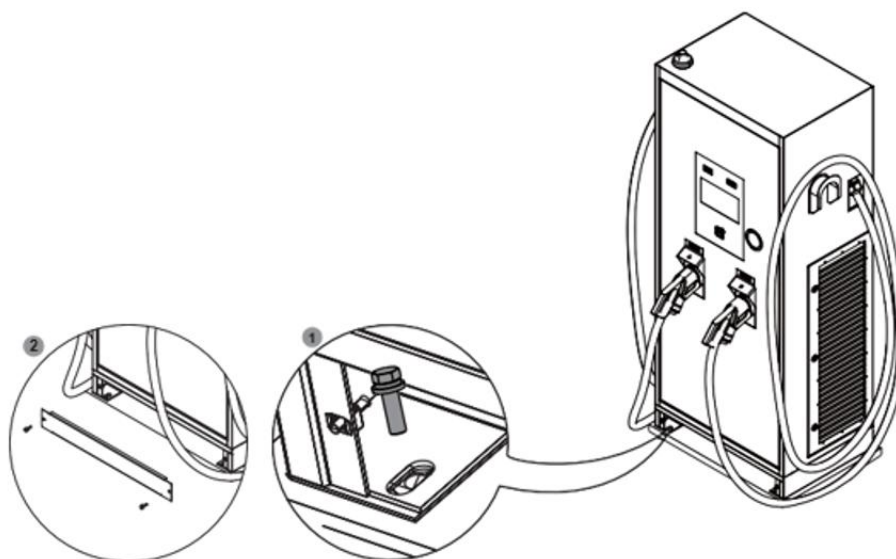

**Step4:** Each power module has a number disc. Find it and use a flat-head screwdriver to rotate the arrow on the disc so that it points to the designated number, as indicated in the above figure.

The number sequence for DC120K is as follows:

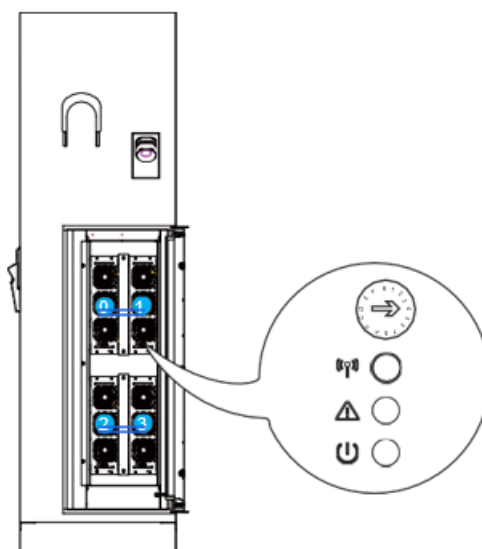

The number sequence for DC 60K is as follows:

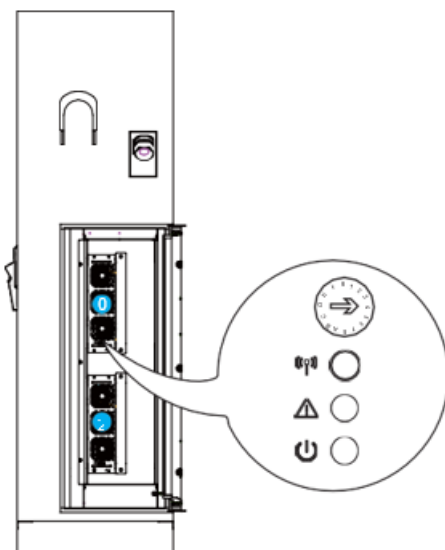

## 4.3. Wiring

### 4.3.1. Connect power cable

	<ul style="list-style-type: none"> <li>• Before wiring, please make sure that the power has been cut off.</li> </ul>
Attention	

**Step1:** he cable is routed in from A and gets out from B to comes into the charger.

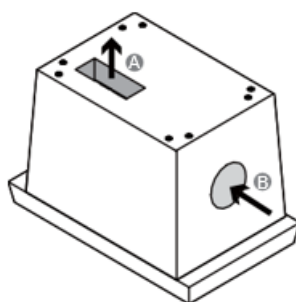

**Step2:** Loosen the screws on the terminals.

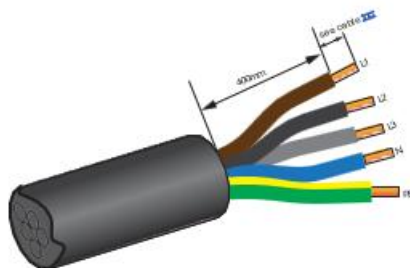

**Step3:** Connect the cable to the correct terminals and tighten the screws clockwise. Pull the power cables to check that the cables are securely connected.

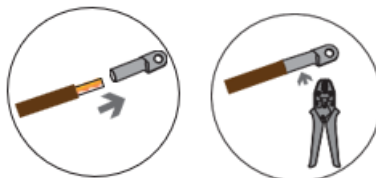

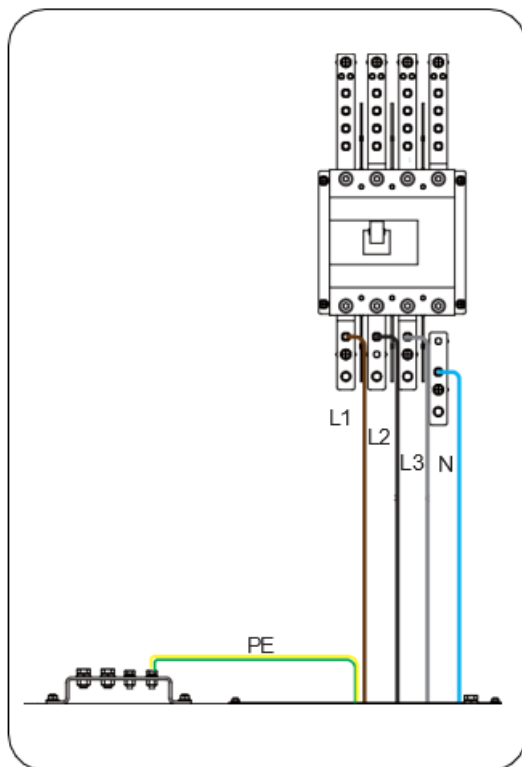

### 4.3.2. Connect communication cable

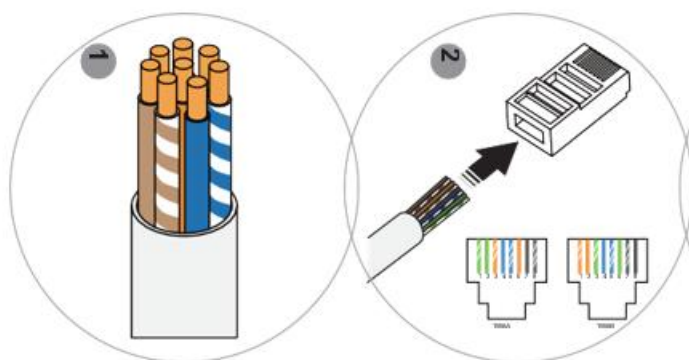

On the gateway PCB, plug the RJ45 connector for Ethernet cable to the appropriate ports.

**Note:** The gateway PCB can be found at section 3 product overview.

## 5. Disposal

The packaging materials are environmentally friendly and can be recycled.

Do not dispose this product with the household waste. It shall be handed over to the applicable collection point for the recycling of electrical and electronic product. For more detailed information, please contact your local city office, household waste disposal service or the local supplier of the product.



## 6. Commissioning

### 6.1. Configure the network for the charger

If you select Wi-Fi or Ethernet for communication, you need to use AP mode to configure the network for the charger.

	<b>AP mode, which is similar to a local area network, operates the internet locally between your phone and the charger.</b>
<b>Attention</b>	

- 1) Set your phone to airplane mode and make sure the WLAN is turned on.
- 2) Restart the charger's power supply to activate the hotspot.
- 3) Locate the charger's wifi hotspot (wifi name: the serial number of the charger) in your phone's Wi-Fi list.
- 4) Enter the password to connect the charger to your phone (password is admin123).

	<b>The hotspot of the charger remains available for 15 minutes after the charger is restarted.</b>
<b>Attention</b>	

**Step1:** Login. To access the LOGIN page of AP mode, enter the IP address 192.168.4.1 in a browser, followed by the 4-digit network password (PIN number, which can be found on the breaker or in the user manual that you find inside).

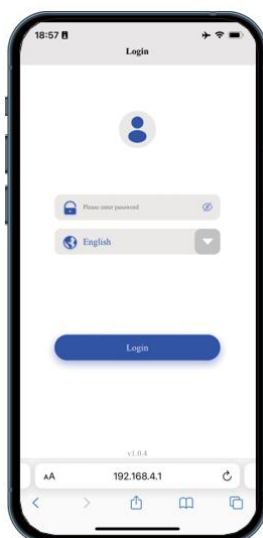

**Step2:** Configure Wi-Fi or Ethernet. After logging in, and you will be prompted with the following interfaces:



 <b>Attention</b>	<b>The address of Evcharge Cloud platform: wss://ocpp16.evcharge.com:33033</b>
---	--

**Step3:** Click  and you will see interface as shown on the right side above, then enter the information to configure the network.

 <b>Attention</b>	<b>Your charge point will automatically restart once the network configuration is complete, ending communication between your phone and the charge point, at this point, your phone may automatically join to other Wi-Fi hotspots, preventing you from accessing the network configuration interface. As a result, before accessing the network configuration interface, please ensure that your phone is connected to the charger's Wi-Fi hotspot.</b>
---	--

## 6.2. Connect charger to Evcharge Cloud Portal

Once the network setting is complete and the charger is online, it is able to connect to the Evcharge platform, where you can configure your charger and charge station.

When you purchase our charger, you will be given an account . With this account, you will be able to log in to our platform (Evcharge cloud: <https://cloud.evcharge.com>) and configure the charger's details.

For details, please click on the link: <https://www.zcsazzurro.com/uploads/documetazione/User-Manual-Evcharge-Portal-1.0-ITA.pdf>

## 7. Operations

### 7.1. Indicator description

Indicator	Description
Yellow indicator keeps on	The charging connector has been plugged in
Green indicator keeps on	Idle
Red indicator keeps on	Faults
Yellow indicator flashes	Alarm (charging connector has been plugged in)
Green indicator flashes	Alarm (idle)

### 7.2. LCD information

Standby/Home page upon power on.



Plug the connector A or B in and choose the start modes.

- With Evcharge App: use the app to start charging session (please scan the Evcharge APP instruction below).
- Use a RFID card to start the charging session.

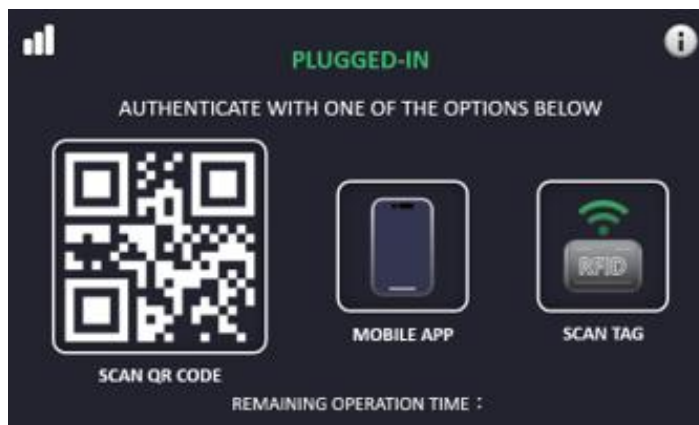

[Evcharge App Instructions](#)

	<p><b>If App is chosen, then have a look on the user manual of App.</b></p>
<p><b>Note</b></p>	

During charging session, and the charging details displayed.



Make payment after the charging finished. The user can terminate the charging session by scanning the QR code or by the RFID card then make payment by adding the bank card.



The payment details as shown.

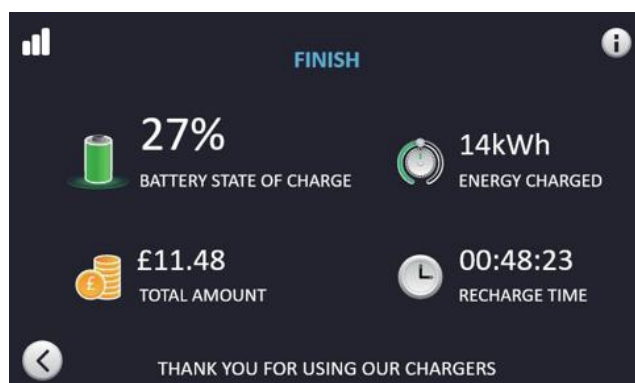

### 7.3. Checks before initial startup

The operation of this DC charger must be performed in accordance with the test instructions outlined below. All of the instructions given below are required and must be followed by the operator of the DC charger.

After transport and installation, check the following points:

Checks	Execution
Mechanical visual inspection	Mechanically perfect condition of all installed devices.
Screw connections, tight fit	Random or complete testing of tightening torques at terminals and mechanical screw connections.
Earthing system	Check if the earthing considers the site-specific conditions as well as the valid standards.
Lightning protections for supply lines	Check if supply line has a lightning protection device in accordance with IEC 61851-1 as well as country-specific norms.
Check the on and off at the AC input side	Use the multimeter to check the voltage and current at the AC input side.
Operating conditions	Consideration of the operating conditions at the installation site (e.g. mechanical, chemical, corrosive stress) according to IEC 61851-1 as well as deviating country-specific standards.
Residual current protection device (if have)	Checking whether a residual current circuit breaker outside the charger is required/has been mounted, in accordance with the site-specific conditions and the valid standards.
Check the charging cable, charging connector, and the outside surface of the cabinet.	Check the charging cable, charging connector and outside surface of the cabinet for damage and scratches, etc.
Check inside the cabinet	Make sure there are no debris, spare parts, etc. inside the chassis.



## 7.4. Checks before switching on for the first time

Checks	Result	
	Ok	Deficient
External visual inspection of the charger (damage, defects)		
Checking the stability		
Inspection of the cable connections		
Inspection of the fuses		
Visual inspection of the screw connections?		
Is the inside of the charger clean and free from traces of condensation?		
Checking the air and creepage distances		
Checking the filter mats		
Mains voltages correct?		
Functional inspection of the electrical protective devices		
Earthing system complete? Potential equalisation connections continuous?		

## 7.5. Checks when switching on for the first time

Checks	Result	
	Ok	Deficient
Check fan noise (if applicable)		
Functional check of the RFID reader		
Checking the function of the screen		
Functional testing of the emergency stop button		
Check the module indicator (green)		

Check the charging connector (dry)		
------------------------------------	--	--

## 8. Operation Instruction

### 8.1.1. Start Charging

Park EV near to the charger, and plug the charging connector into the EV. After plug-in, please check the connector is correctly and tightly connected. With appropriate connection, the charger will start charging the EV. The charger screen will display Charging status and the running information, such as charged time, voltage, current and power.

### 8.1.2. Start Charging

In charging state before the EV is fully charged, the user can stop charging by press the Stop button. When the EV is fully charged, the charging will stop and the screen will display End status, then the charging connector can be pulled out directly. When the voltage drops below 50V, the charging session will end, and the user can pull the connector out.

### 8.1.3. Stop Charging

In charging state before the EV is fully charged, the user can stop charging by press the Stop button. When the EV is fully charged, the charging will stop and the screen will display End status, then the charging connector can be pulled out directly. When the voltage drops below 50V, the charging session will end, and the user can pull the connector out.





### 8.1.4. Charger Setting

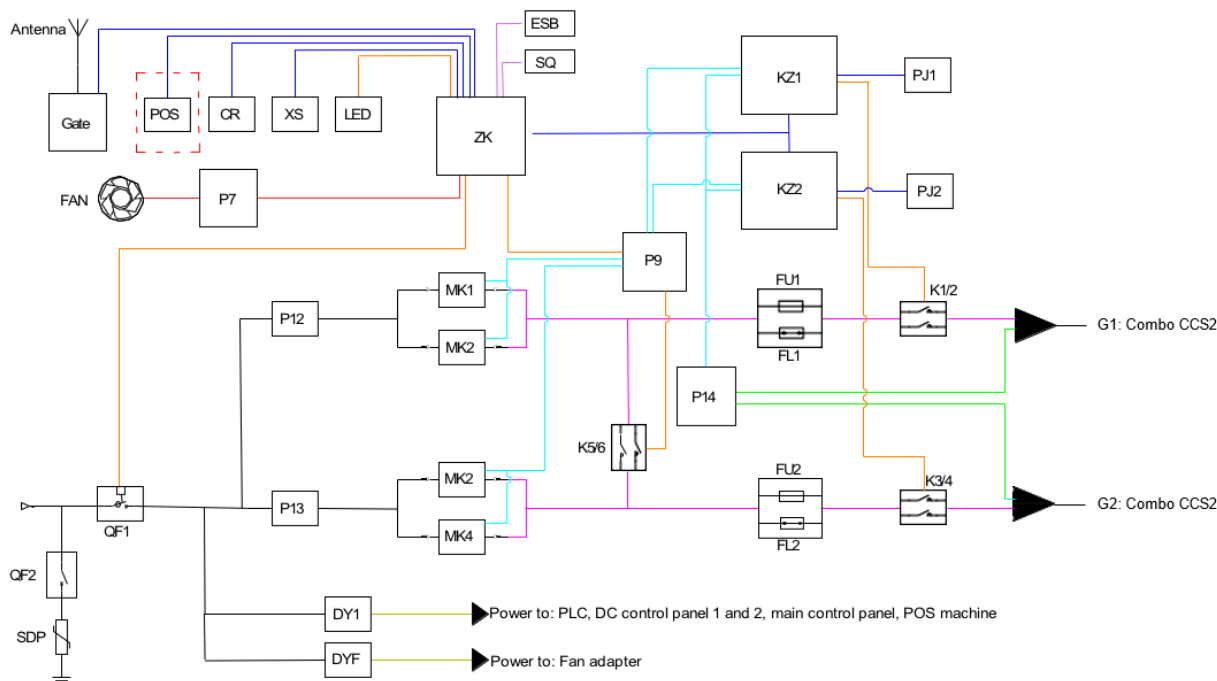



There is a touch screen on the charger interface, which are used to set relative parameters such as: current limit, module voltage/current, module voltage/current etc.

## 9. Appendix-Working principle diagram for ZVD-120K-POWER



<b>QF1/QF2</b>	Circuit breaker	<b>ZK</b>	Main control panel
<b>SPD</b>	Lightning arrester	<b>KZ1/KZ2</b>	DC control panel
<b>DY1/DYF</b>	Auxiliary switching power supply	<b>P14</b>	PLC
<b>P12/P13</b>	AC filter	<b>P7</b>	Fan adapter
<b>MK1/MK2/MK3/MK4</b>	Power module	<b>LED</b>	LED light board
<b>K1/K2/K3/K4/K5/K6</b>	DC contactor	<b>XS</b>	Display screen
<b>FU1/FU2</b>	Fuse	<b>FCR</b>	Card reader
<b>FL1/FL2</b>	Shunt	<b>ESB</b>	Emergency stop
<b>PJ1/PJ2</b>	DC watt-hour meter	<b>SQ</b>	Entrance control
<b>LED</b>	LED light board	<b>P9</b>	Equalizing board
<b>G1/G2</b>	Charge cable		
<b>POS</b>	POS terminal		







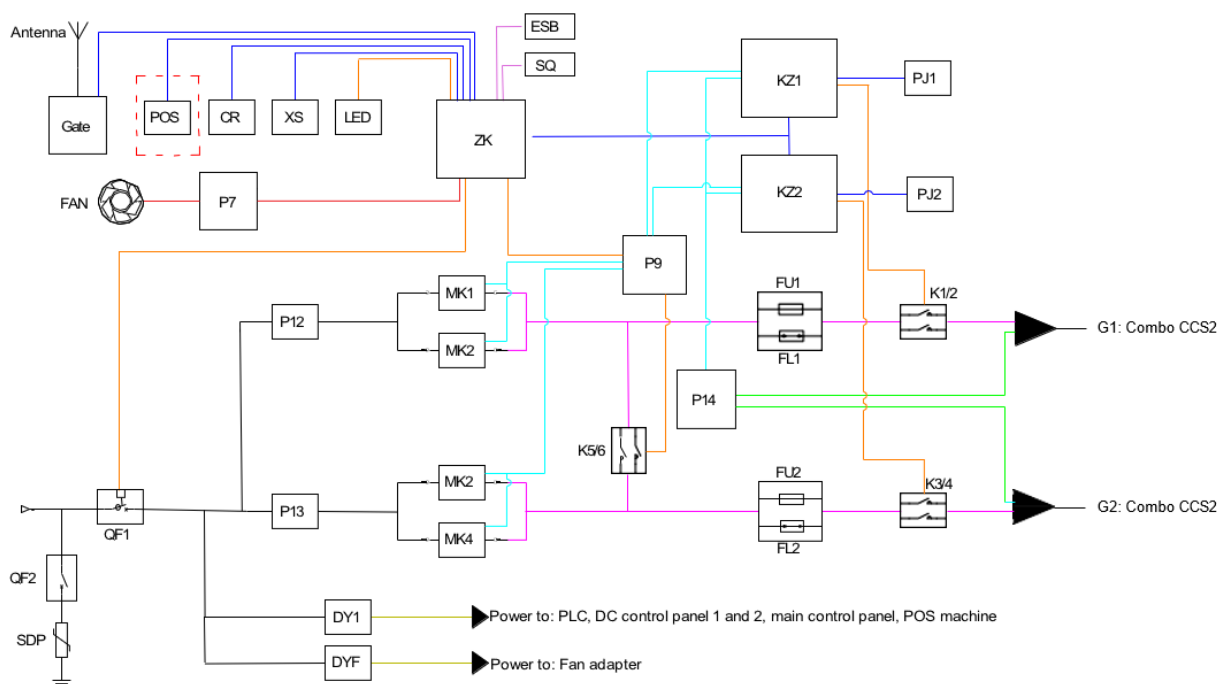

COLOR	DESCRIPTION
	AC power line
	DC power line (high voltage)
	CAN communication line
	485,232, 4222 serial interface

	communication
	Control line
	PWM line
	Feedback
	PLC communication line
	DC power line (undervoltage)

## 10. Appendix-Working principle diagram for ZVD-60K-POWER



<b>QF1/QF2</b>	Circuit breaker	<b>ZK</b>	Main control panel
<b>SPD</b>	Lightning arrester	<b>KZ1/KZ2</b>	DC control panel
<b>DY1/DYF</b>	Auxiliary switching power supply	<b>P14</b>	PLC
<b>P12/P13</b>	AC filter	<b>P7</b>	Fan adapter
<b>MK1/MK2/MK3/MK4</b>	Power module	<b>LED</b>	LED light board
<b>K1/K2/K3/K4/K5/K6</b>	DC contactor	<b>XS</b>	Display screen
<b>FU1/FU2</b>	Fuse	<b>FCR</b>	Card reader
<b>FL1/FL2</b>	Shunt	<b>ESB</b>	Emergency stop
<b>PJ1/PJ2</b>	DC watt-hour meter	<b>SQ</b>	Entrance control
<b>LED</b>	LED light board	<b>P9</b>	Equalizing board
<b>G1/G2</b>	Charge cable		
<b>POS</b>	POS terminal		

COLOR	DESCRIPTION
	AC power line
	DC power line (high voltage)
	CAN communication line
	485,232, 4222 serial interface communication
	Control line
	PWM line
	Feedback
	PLC communication line
	DC power line (undervoltage)

## 11. LED Indicator

There are 2 LED indicators next to charger interface.

State	Description	LED Status
Standby	Power-on, and no connector plug-in	Green light normally on
Ready to charge	Connector plug-in, and charging not started yet	Yellow light flashing at the interval of 1S
In charging	Charging started	Green light flashing at the interval of 1S
Stop charging	Charging stop with connector plugged in	Yellow light normally on
Fault	Error happens	Red light normally on



## 12. Technical datasheet

Dati tecnici	ZVD-60K-POWER/P ZVD-60K-POWER/D
<b>Dati tecnici ingresso AC</b>	
Tipo di connessione	Trifase (3PH + Neutral + PE)
Tensione ingresso AC	400V +/- 10%
Corrente ingresso AC nominale	96A
Frequenza ingresso AC	50/60Hz
Fattore di potenza	>0.99% (dal 50% al 100% della potenza)
THD	<5% (al 100% della potenza)
<b>Dati tecnici uscita DC</b>	
Tensione uscita DC	200-500V (CHAdEMo) 200-1000V (CCS2)
Corrente massima uscita DC	125A (CHAdEMo) 300A (CCS2)
Potenza massima	60kW
<b>Dati generali</b>	
Connettori di ricarica	1x CHAdEMO, 1x CCS2 (ZVD-60k-POWER-D) 2x CCS2 (ZVD-60k-POWER-P)
Lunghezza cavi	5m
Installazione	Su piattaforma in cemento
Schermo LCD	LCD display 10.1" touch screen
Start ricarica	RFID Card, APP, Plug-In
Energy Meter	Certificato MID
Protezione RCD	TipoA + 6mA DC
Grado di protezione	IP54 (ambientale) IK07 (da impatto)
Raffreddamento	Ventole interne su moduli
Stop di emergenza	Sì
Comunicazione	Wifi, Ethernet
Protocollo	OCPP 1.6 JSON (possibile upgrade a JSON 2.0)
Efficienza massima di conversione	95%
<b>Dati ambientali</b>	
Temperatura di esercizio	-30°C / +50°C
Umidità	5% / 95% senza condensazione
Massima altitudine	2000mt
Installazione	Indoor / Outdoor
<b>Protezioni e sicurezza</b>	
Protezioni integrate	sotto tensione, Sovraccarico di potenza, Corto circuito, Correnti di dispersione, Mancanza di terra, Surge, Sovra e sotto temperatura
Standard di sicurezza applicabili	IEC 61851-1: 2019, EN 61851-23:2014, EN 61851-24:2014
Garanzia	2 anni
<b>Dimensioni e parti accessorie</b>	
Dimensioni (A x L x P)	1830mm x 750mm x 525mm
Dimensioni cassa di legno (A x L x P)	2020mm x 1020mm x 750mm
Peso	228 kg
Peso comprensivo di cassa di legno	268,5 kg

## 13. Troubleshooting and maintenance

### 13.1. Troubleshooting

This section contains information and procedures on how to troubleshoot any faults and errors that may occur during operation of the charging station.

If you have any problems please follow these steps:

- 1) Check the warning messages and error codes on the information panel of the device. Record them before carrying out any further operation.
- 2) If the charging station does not display any errors, perform the following checks:
  - Is the device located in a clean, dry and properly ventilated place?
  - Are the cables correctly sized and as short as possible?
  - Are the connections in good condition?
  - Are the configuration settings correct for the type of installation?

Information on the event list:

Code	Possible causes	Solutions
1	Input voltage over	1. Check the input voltage.
		2. If the voltage is over 480Vac for a short time, wait till the power grid recovers to normal voltage range.
2	Input voltage lower	1. Check the input voltage from the backend.
		2. If the voltage is under 320Vac for a short time, wait till the power grid recovers to normal voltage range.
3	Input frequency over	1. Check the input voltage frequency from the backend.
		2. If the frequency exceeds 63Hz for a short time, wait till power grid recover to normal voltage range.
4	Input frequency lower	1. Check the input voltage frequency from the backend.
		2. If the frequency is lower than 47Hz for short time, wait till power grid recover to normal voltage range.

5	Over temperature	Check the surrounding conditions of chargers installed whether there is heating device nearby. Make sure environmental temperature is under 60°C.
6	Output over-voltage	Check whether the output voltage is within parameters setting range. If not, please check whether the output voltage/current is too high, or the parameters setting is reasonable.
7	Grounding fault	Check whether the grounding connection cables are connected correctly.
8	Emergency stop	Check whether the emergency stop has been pressed, then correct the error and recover the emergency stop button.
9	Charging connection abnormal cable	Check if charging cable connection is correct and firm.
E000	The control board is overheated.	
E002	Mains power overvoltage or undervoltage.	
E004	The output current exceeds 35.2A	
E005	Mains power overvoltage or undervoltage	
E007	The DC leakage current A is abnormal	
E008	Emergency stop	
E010	RCD value is abnormal	
E011	The terminal at the input side is overtemperature	



E014	Relay adhesion
E015	The PE of the charging connector is not grounded.
E016	The L1 line and N line at the input side are connected reversely
E017	AC RCD circuit error
E022	Meter communication failure
E023	AC CP voltage error
E024	The set demand voltage exceeds the maximum output voltage of the charger
E025	The set demand current exceeds the maximum output current of the charger
E027	The DC connector K1/K2 error
E031	DC leakage current C is abnormal
E032	The voltage during the insulation testing phase did not meet the requirements.
E033	It is detected that vehicle contactor K5K6 is closed before insulation
E038	The charging connector is overtemperature
E039	DC connector (on the display board) failure
E040	The battery voltage is incorrect
E041	The module address error
E043	Module output is short-circuit

E044	The module is not enabled,unavailable
E048	The main control board is overtemperature
E053	The output voltage exceeds the maximum allowable voltage by 110% for 200ms.
E054	Door access control failure
E055	Card reader communication error
E056	Screen communication error
E057	Communication failure between main control board and the control board
E059	The insulation resistance is too small and charging is not allowed
E061	Excessive deviation of demand voltage from charging connector voltage (output > demand)
E062	The CP signal is abnormal during charging
E063	The output wires are connected reversely

**Note:** If the above problems cannot be resolved, please contact the manufacturer.

## 13.2. Maintenance

	<p><b>Please note that the maintenance should be done by the qualified person. For maintenance of non-electrical parts, please disconnect the power supply first</b></p>
<b>Attention</b>	

For the safe operation of the fast charger, regular maintenance or control of the safety equipment is required. All the points listed below are considered mandatory and must be carried out by the operator at the intervals described.

The following table gives an overview of the required maintenance work. Depending on the individual operating conditions of the fast charger, further maintenance work may still be necessary so the list below cannot be considered complete.

Maintenance work	Execution	Interval
Charging cable	Replacement of the complete charging cable	Daily
Residual current devices	Function test of residual current circuit breaker, Open the service door and press the indicated button of the circuit breaker at the bottom of the fast charger.	Once a month
Main switch, voltage release switch	Verify the correct function	Half a year
Verification of protective measures	With the charger switched off, check the resistance between the ground of the supply and all externally accessible, non-insulated cabinet parts (housing, add-on parts, screws)	Quarterly

Check for cleanliness and condensation	<p>Check if the interior of the control cabinet is clean and without any traces of condensation.</p> <p>Check the water run-off on cable plug holder and charging connector.</p> <p>Check the seal for damage and correct positioning.</p>	Daily
Screw and lock	<p>Random or complete testing of tightening torques at terminals and mechanical screw connections. Check whether the lock is locked or damaged, and whether the fixing screws are loose.</p>	Daily
Overtoltage protection	<p>Check the surge arrester for full function</p>	Half a year
Ventilation filters	<p>Replacement of filters (Depending on the working environment)</p>	Depending on the working environment.
Charging cable	<p>Check if the charging cable is in perfect condition. Make sure that all cable parts (cable, connector, pins, cable sleeve, locking mechanism) are free from dirt, crushing, cracks, wear, burns or other damages. Also check that the insulation is intact and that all screws are tight.</p>	Daily
Cheaning the charger	<p>Regularly clean the external surface of the charger.</p>	<p>Depending on the working environment ,external cleaning and inspection may be required more regularly than other maintenance task.</p>

Function test of the emergency stop	Press the emergency stop button, and the code "E008" displayed on the screen.	Once a month
-------------------------------------	---	--------------

## 14. Dismantling and disposal

The packaging materials are compatible with the environment and can be recycled. Therefore, they can be disposed of in special recycling containers in accordance with the local waste disposal regulations. However, the charger cannot be disposed of as household waste, but must be treated as special waste. It must be disposed of at facilities authorised to dispose of electrical and electronic goods. For more detailed information on the disposal and recycling of this product, please contact the local competent office, waste disposal service or the retailer where you purchased the charger.

### 1) Uninstalling

- Disconnect the charging station from the AC network
- Remove the AC terminals
- Remove any communication connections
- Unscrew the fixing screws and remove from the metal part or support

### 2) Packaging

If possible, pack the charging station in its original packaging.

### 3) Storage

Store the charging station in a dry place where the ambient temperature is between -25°C and +60°C.

### 4) Disposal

At the end of its life, dispose of the charging station and packaging materials in places that can manage and recycle electrical equipment safely.



Where present, the crossed-out bin symbol indicates that the product, at the end of its life, must not be disposed of with domestic waste.

This product must be delivered to your community waste collection point local for its recycling.

For more information, refer to the body responsible for waste disposal in your country. Inappropriate waste disposal can have negative effects on the environment and human health due to potentially dangerous substances.

By cooperating in the proper disposal of this product, you are contributing to the reuse, recycling and recovery of this product, as well as to the protection of our environment.

## 15. Warranty

Zucchetti Centro Sistemi SpA provides a warranty of 2 years from the date of installation of the charging station, subject to registration on the website

<https://www.zcsazzurro.com/it/estensione-garanzia>. During the warranty period, Zucchetti Centro Sistemi S.p.A. guarantees the normal operation of the charging station.

If the device is defective or faulty during the warranty period, contact your installer or supplier. If the fault falls within the responsibility of the manufacturer, Zucchetti Centro Sistemi S.p.A. will provide service and maintenance free of charge.

### Warranty exclusions:

- Use of the charging station for any other use other than the intended one.
- Defective or faulty design or installation of the system.
- Improper use of the device.
- Incorrect configuration of the outer protections.
- Unauthorised modifications to the device.
- Damage caused by external factors or force majeure (e.g. lightning, power surges, bad weather, fire, earthquakes, tsunamis, etc.)